

# **LTE and 5G Innovation: Igniting Mobile Broadband**



## Table of Contents

<b>INTRODUCTION.....</b>	<b>5</b>
<b>EXPLODING DEMAND .....</b>	<b>8</b>
Smartphones and Tablets .....	8
Application Innovation .....	9
Internet of Things .....	10
Video Streaming .....	10
Cloud Computing .....	11
5G Data Drivers.....	11
Global Mobile Adoption .....	11
<b>THE PATH TO 5G.....</b>	<b>15</b>
Expanding Use Cases .....	15
1G to 5G Evolution.....	17
5G Concepts and Architectures .....	20
Information-Centric Networking.....	25
3GPP Releases.....	26
<b>SUPPORTING TECHNOLOGIES AND ARCHITECTURES .....</b>	<b>33</b>
Types of Cells.....	33
Small Cells and Heterogeneous Networks .....	34
Internet of Things and Machine-to-Machine.....	37
Unlicensed Spectrum Integration .....	39
Smart Antennas and MIMO .....	41
Virtualization.....	42
Fixed Mobile Convergence and IMS .....	44
Multicast and Broadcast.....	45
<b>VOLTE, RCS, WEBRTC, AND WI-FI CALLING .....</b>	<b>46</b>
Voice Support and VoLTE.....	46
Rich Communications Suite .....	47
WebRTC .....	48
Wi-Fi Calling.....	48
<b>PUBLIC SAFETY .....</b>	<b>50</b>
LTE Features for Public Safety .....	50
Deployment Schedule and Approaches .....	52
Device Considerations for Public Safety .....	53
<b>EXPANDING CAPACITY.....</b>	<b>55</b>
<b>SPECTRUM DEVELOPMENTS.....</b>	<b>60</b>
AWS-3.....	62
Incentive Auctions (600 MHz).....	62
3550 to 3700 MHz "Small-Cell" Band.....	63
5G Bands.....	63
Harmonization.....	64
Unlicensed Spectrum.....	66
Spectrum Sharing .....	68
<b>CONCLUSION.....</b>	<b>72</b>

<b>APPENDIX: TECHNOLOGY DETAILS .....</b>	<b>73</b>
Data Throughput Comparison .....	73
Latency Comparison .....	78
Spectral Efficiency.....	78
Data Consumed by Video .....	85
CDMA2000 .....	86
WiMAX .....	88
Spectrum Bands .....	89
UMTS-HSPA .....	92
HSDPA .....	93
HSUPA .....	96
Evolution of HSPA (HSPA+).....	97
Advanced Receivers .....	97
MIMO .....	98
Continuous Packet Connectivity .....	99
Higher Order Modulation.....	99
Multi-Carrier HSPA .....	99
Downlink Multiflow Transmission .....	100
HSPA+ Throughput Rates .....	101
UMTS-HSPA Voice .....	105
Improved Circuit-Switched Voice .....	105
Circuit-Switched (CS) Voice over HSPA.....	106
VoIP .....	107
LTE .....	108
LTE Throughput Rates .....	109
OFDMA and Scheduling .....	110
LTE Smart Antennas .....	112
IPv4/IPv6 .....	116
VoLTE and RCS .....	117
TDD Harmonization.....	122
SMS in LTE .....	123
LTE-Advanced .....	123
Carrier Aggregation .....	124
LTE-Advanced Antenna Technologies .....	130
Coordinated Multi Point (CoMP) .....	133
User Equipment Categories.....	135
LTE-Advanced Relays .....	136
Internet of Things and Machine-to-Machine.....	137
Proximity Services (Device-to-Device).....	138
LTE Throughput.....	138
Heterogeneous Networks and Small Cells.....	145
Enhanced Inter-cell Interference Coordination .....	148
Dual Connectivity .....	153
Self-Organizing Networks (SON) .....	155
Evolved Packet Core (EPC).....	156
Unlicensed Spectrum Integration .....	159
Release 6 I-WLAN.....	160
Release 8 Dual Stack Mobile IPv6 and Proxy Mobile IPv6 .....	160
Release 11 S2a-based Mobility over GTP .....	160
LTE-U, LTE License Assisted Access, LTE Wi-Fi Aggregation.....	162

Multipath TCP.....	162
ANDSF .....	162
Bidirectional Offloading Challenges .....	163
Other Integration Technologies (SIPTO, LIPA, IFOM, MAPCON).....	165
Hotspot 2.0.....	165
IP Multimedia Subsystem (IMS) .....	166
Cloud Radio-Access Network (RAN) and Network Virtualization .....	167
Broadcast/Multicast Services .....	170
Backhaul.....	171
UMTS TDD .....	173
TD-SCDMA.....	173
EDGE/EGPRS.....	174
TV White Spaces.....	176
<b>ABBREVIATIONS AND ACRONYMS.....</b>	<b>178</b>
<b>ADDITIONAL INFORMATION .....</b>	<b>187</b>

Copyright ©2015 Rysavy Research, LLC. All rights reserved. <http://www.rysavy.com>

# Introduction

The mobile broadband industry continues to expand, transforming both businesses and lives. Twenty years ago, handheld computing and wireless-data communications were niche technologies, employed primarily in vertical-market industries. Today, the number of connected devices is larger than the population of the United States.

The industry would be exciting even if it had reached a final endpoint, but it is only at an early stage of development, with no end in sight for the range of potential improvement. For example, over the past five years, peak achievable LTE throughput rates have increased from tens of megabits per second to hundreds of megabits per second. Now, with 5G development accelerating, engineers are planning another tenfold or greater increase in throughput.

By using spectrally more efficient technology, harnessing new spectrum in ever-higher frequency bands, and increasing network density, the industry will increase network capacity by two to three orders of magnitude over the next ten years. Although radio communications cannot match the capacity of fiber-optic cable, the capabilities of mobile broadband are becoming so powerful that an increasing percentage of users will no longer need wireline broadband connections.

Not only is wireless technology the means by which humans are connecting with one another and their work, it is also how we will eventually connect tens of billions of machines, whether health monitors, self-driving cars, or countless other devices for which applications have not yet even been conceived. 5G, with its greater capabilities, will expand use cases even further.

Globally, the cellular industry has converged on 3GPP Long Term Evolution (LTE), including LTE-Advanced, as the common air interface. An industry that was previously fragmented among multiple air interfaces—Global System for Mobile Communication (GSM), Universal Mobile Telecommunications System (UMTS)/High Speed Packet Access (HSPA), Code Division Multiple Access 2000 (CDMA2000), Worldwide Interoperability for Microwave Access (WiMAX)—now has one standard, resulting in huge economies of scale for infrastructure and user equipment. 5G will become an extension of this communications platform.

In local area networks, Wi-Fi has also achieved remarkable success. With ongoing developments to more tightly integrate Wi-Fi operation with LTE, as well as extending LTE operation into unlicensed bands, the industry is about to realize the vision of one global, harmonized network.

Table 1 summarizes the most important developments occurring in the wireless industry and explained in this paper.

**Table 1: Most Important Wireless Industry Developments in 2015.**

Development	Summary
<b>LTE Becomes the Global Cellular Standard</b>	A previously fragmented wireless industry has consolidated globally on LTE.  LTE is being deployed faster than any previous generation of wireless technology.

Development	Summary
<b>LTE-Advanced Provides Dramatic Advantages</b>	<p>Carrier Aggregation, a key LTE-Advanced feature that operators are deploying globally, harnesses available spectrum more effectively, increases network capacity, and can increase user throughput rates.</p> <p>Other features in early stages of deployment or being tested for deployment include: Self-Organizing Network (SON) capabilities in the radio-access network, Enhanced Inter-Cell Interference Coordination (eICIC) for small cells that use the same radio channels as the macro cell, and Coordinated Multi Point (CoMP) transmission so multiple sites can simultaneously process signals from mobile users, improving cell-edge performance.</p>
<b>5G Research and Development Gains Momentum</b>	<p>5G, in early stages of definition through global efforts and many proposed technical approaches, could start to be deployed close to 2020 and continue through 2030.</p> <p>5G will be designed to integrate with LTE networks, and many 5G features may be implemented as LTE-Advanced extensions prior to full 5G availability.</p>
<b>Internet of Things Poised for Massive Adoption</b>	<p>IoT, also called machine-to-machine (M2M) communications, is seeing rapid adoption and expected in tens of billions of devices over the next ten years.</p> <p>Drivers include improved LTE support, other supporting wireless technologies, and service-layer standardization such as OneM2M.</p>
<b>Spectrum Still Precious</b>	<p>Spectrum remains a precious commodity for the industry; its value was demonstrated by the recent Advanced Wireless Services (AWS) auction that achieved record valuations.</p> <p>Forthcoming spectrum in the United States includes the 600 MHz band planned for auction in 2016 and the 3.5 GHz "small-cell" band that the Federal Communications Commission (FCC) is in the process of deploying.</p> <p>5G spectrum will include bands above 30 GHz, called mmWave, with the potential of ten times as much spectrum as is currently available for cellular. Radio channels of 1 GHz or more will enable multi-Gbps peak throughput.</p>
<b>Unlicensed Spectrum Becomes More Tightly Integrated with Cellular</b>	<p>The industry has developed increasingly sophisticated means for Wi-Fi and cellular networks to interoperate, making the user experience ever more seamless.</p> <p>The industry is also developing versions of LTE that can operate in unlicensed spectrum.</p>
<b>Mobile Computing Overtakes the Desktop</b>	<p>The number of mobile users globally now exceeds the number of desktop users.</p>

Development	Summary
<b>Small Cells Take Baby Steps</b>	<p>Operators have begun installing small cells. Eventually, millions of small cells will lead to massive increases in capacity.</p> <p>The industry is slowly overcoming challenges that include site acquisition, self-organization, interference management, and backhaul.</p>
<b>Network Function Virtualization (NFV) Emerges</b>	<p>New network function virtualization (NFV) and software-defined networking (SDN) tools and architectures are enabling operators to reduce network costs, simplify deployment of new services, and scale their networks.</p> <p>Some operators are also virtualizing the radio-access network, as well as pursuing a related development called cloud radio-access network (cloud RAN).</p>

The main part of this paper covers exploding demand for wireless services, the path to 5G, supporting technologies and architectures, voice over LTE, Wi-Fi calling, LTE for public safety, options to expand capacity, and spectrum developments.

The appendix delves into more technical aspects of the following topics: data throughput, latency, UMTS/WCMA<sup>1</sup>, HSPA, HSPA+, LTE, LTE-Advanced, HetNets, Small Cells, self-organizing networks, the evolved packet core, unlicensed spectrum integration, the IP multimedia subsystem, cloud radio-access networks, broadcast/multicast services, backhaul, UMTS TDD, Time-Division Synchronous Code Division Multiple Access (TD-SCDMA), EDGE, and TV white spaces.

---

<sup>1</sup> Although many use the terms "UMTS" and "WCDMA" interchangeably, in this paper "WCDMA" refers to the radio interface technology used within UMTS, and "UMTS" refers to the complete system. HSPA is an enhancement to WCDMA. LTE with EPC is a completely new architecture.

# Exploding Demand

Mobile broadband satisfies an inherent human and business need: to do more without being tied to a physical location. Two technology vectors have collided and reached critical mass: handheld computing and fast wireless connections. This computing and communications platform encourages the innovation that has produced millions of applications.

Until now, human interaction has driven wireless demand, but communicating machines will be a third vector that expands demand to an even higher level. What types of things communicate and how they do so will vary far more than human communication. Predicting whether, over the next decade, the Internet of Things (IoT) contributes to demand by a factor of ten or a hundred is impossible. IoT's massive impact, however, is inevitable.

**Figure 1: Exploding Demand from Critical Mass of Multiple Factors**

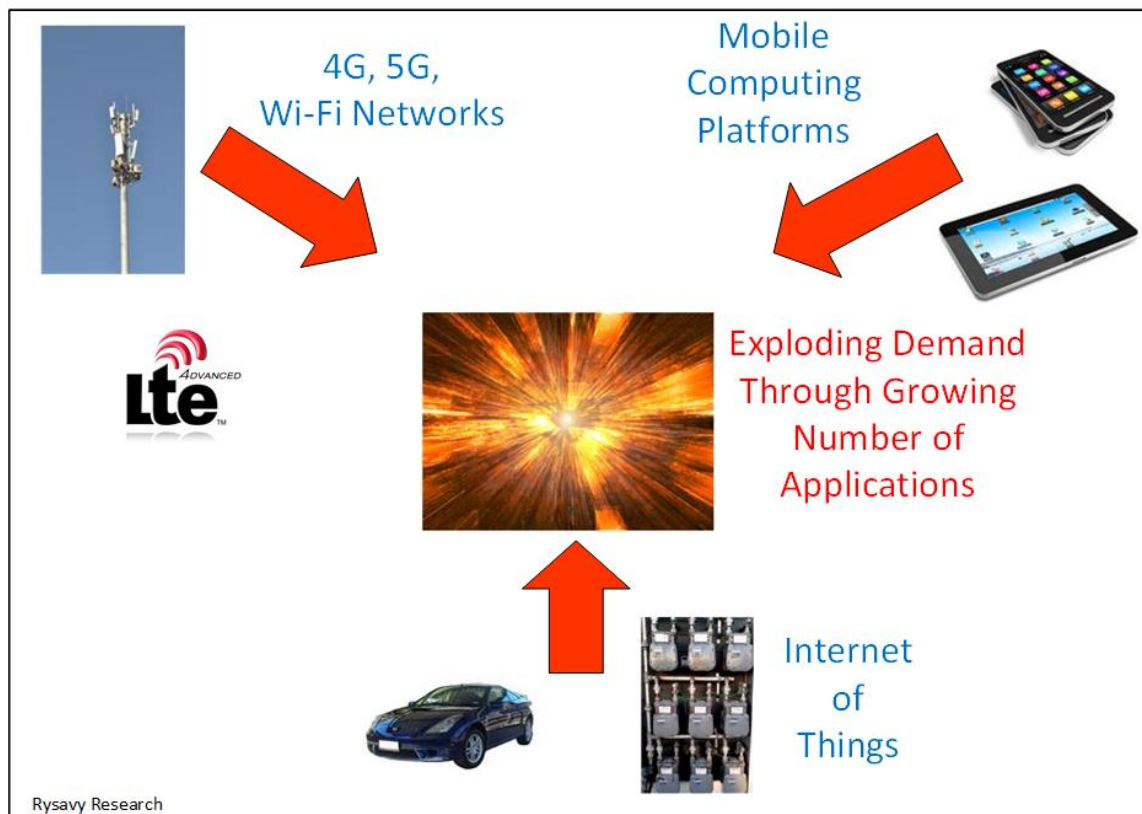

This section explores these various demand factors.

## ***Smartphones and Tablets***

Today's smartphones and tablets have raw capability that makes millions of mobile applications possible:

- ❑ Processors clocked at over 1 GHz.
- ❑ Memory ranging from 16 GB to 128 GB able to store thousands of songs and many hours of video.



- ❑ Motion processing.
- ❑ Multiple radio interfaces, including 2G to 4G, Bluetooth, Wi-Fi, and GPS.
- ❑ High-definition screens, such as 1920 X 1080 (referred to as 1080p), exceeding in many cases the resolution of human eyes.
- ❑ High-performance still and motion cameras.
- ❑ Sophisticated multi-tasking operating systems.
- ❑ Voice recognition and artificial intelligence.

Because they always carry these devices, users are likely to use a wider variety of applications than at a stationary computer. The rich capabilities of these mobile platforms enable users to consume ever larger amounts of data through music and video streaming, social networking, cloud synchronization, cloud/Web-based applications, Web browsing, content downloading, navigation, transportation, and more.

With similar capabilities across different mobile OS platforms and millions of available applications, today's mobile, touch-based computers have become indispensable for billions of people.

## ***Application Innovation***

When planning 4G network technology, who could have predicted applications such as Uber and Lyft, which combine location information with mapping and online payment, and now are disrupting the taxi industry and even challenging notions of private vehicle ownership? While some applications of new technology can be predicted, many cannot.

More efficient technology not only addresses escalating demand, it also provides higher performance, thus encouraging new usage models and increasing demand even further. For example, Mobidia reports that in December 2014, Android 4G smartphone users averaged 2.4 GB monthly usage compared with 1.1 GB for 3G smartphone users.<sup>2</sup>

Developers have an increasing number of tools at their fingertips to develop mobile applications, including:

- ❑ Ever richer platform-specific developer tools.
- ❑ Increasing capability in Web-based tools, such as HTML5, for applications that operate across multiple platforms. Hybrid HTML5/native apps are also becoming common.
- ❑ New application programming interfaces (APIs) for accessing mobile-specific functions, including WebRTC (Web Real Time Communications), speech, short message service (SMS), multimedia messaging service (MMS), in-app messaging, address books, advertising, and device capabilities.

---

<sup>2</sup> Mobidia press release, "New Global Research Demonstrates LTE Drives up Cellular Data Consumption," Feb. 12, 2015.

- Cloud-based support for applications, such as IoT and mobile commerce (for example, cloud-based wallets).

Of concern to many companies in the wireless industry, however, are new network neutrality rules that could hamper innovation. By restricting prioritization, for example, the rules seem to fail to recognize that traffic from different applications inherently have different quality-of-service requirements.<sup>3</sup>

## ***Internet of Things***

Early Internet of Things applications include vehicle infotainment, home health, transportation and logistics, security and home automation, manufacturing, construction and heavy equipment, healthcare, and digital signage. Municipalities, evaluating what constitutes “smart cities,” are exploring how to optimize pedestrian and vehicular traffic, connect utility meters, and deploy trash containers that can report when they need emptying.

Although promising, the IoT market is also challenging, with varying communications requirements, long lifetimes, demanding battery requirements, cost sensitivity, security concerns, unsuitability of conventional networking protocols for some applications, and other factors that application developers must address. Streamlining processes and developing supporting infrastructure will take time. The IoT market is not monolithic, but ultimately thousands of markets. Success will occur one sector at a time, and success in one area may provide the building blocks for another.

Over time, the internetworking of things will continue because of the cost savings, and competitive advantages delivered. To address the opportunity, 3GPP is defining progressive LTE refinements that occur over multiple 3GPP releases, including low-cost modules in Release 13 that could match 2G module pricing. See the sections on Internet of Things, below and in the appendix, for more details.

## ***Video Streaming***

Video represents the greatest usage of data on smartphones. Just an hour a day of mobile video at 1.0 Mbps throughput, typical with YouTube or Netflix, consumes 13.5 GB per month. See the Appendix section, “Data Consumed by Video,” for a quantification of data consumed by video for multiple usage scenarios.

An increasing number of video applications, including Netflix and Skype, adapt their streaming rates based on available bandwidth. By doing so, they can continue to operate even when throughput rates drop. Conversely, they take advantage of higher available bandwidth to present video at higher resolution. Fortunately, application developers are becoming sensitive to bandwidth constraints and are offering options for users to reduce consumption.

---

<sup>3</sup> For further discussion, see Rysavy Research, *How Wireless is Different – Considerations for the Open Internet Rulemaking*, September 12, 2014. Available at <http://www.rysavy.com/Articles/2014-09-Wireless-Open-Internet.pdf>.

## ***Cloud Computing***

Cloud computing inherently increases data consumption because it requires communications for all operations. Examples include data synchronization and backup, cloud-based applications (such as email, word processing, and spreadsheets), automatic photo uploads, and music and video streaming.

## ***5G Data Drivers***

Some applications of 5G can be predicted, but many, if not most, will arise as industries evolve or come into existence to take advantage of new network capabilities. Some potential applications of 5G include:

- ❑ Ultra-high-definition, such as 4K and 8K, and 3D video.
- ❑ Augmented and immersive virtual reality.
- ❑ Realization of the tactile Internet—real-time, immediate sensing and control, enabling a vast array of new applications.
- ❑ Automotive, including autonomous vehicles, driver-assistance systems, vehicular Internet, infotainment, inter-vehicle information exchange, and vehicle pre-crash sensing and mitigation.
- ❑ Monitoring of critical infrastructure, such as transmission lines, using long-battery-life and low-latency sensors.
- ❑ Smart transportation using data from vehicles, road sensors, and cameras to optimize traffic flow.
- ❑ Mobile health and telemedicine systems that rely on ready availability of high-resolution and detailed medical records, imaging, and diagnostic video.
- ❑ Public safety, including broadband data and mission-critical voice.
- ❑ Sports and fitness enhancement through biometric sensing, real-time monitoring, and data analysis.

Many of these applications are already being addressed by 4G, but 5G, because of its lower costs, higher throughputs, and lower latency, will permit broader realization of their potential.

In addition, a growing percentage of users will be able to rely on 5G as their only form of broadband connection, continuing the cord-cutting trend that began with voice service and that now extends to broadband data service.

## ***Global Mobile Adoption***

Figure 2 shows the often-cited Cisco projection of global mobile data growth through 2019, measured in exabytes (billion gigabytes) per month, demonstrating traffic growing at a compound annual rate of 57%—resulting in ten-fold growth over that period.

**Figure 2: Global Mobile Data Growth<sup>4</sup>**

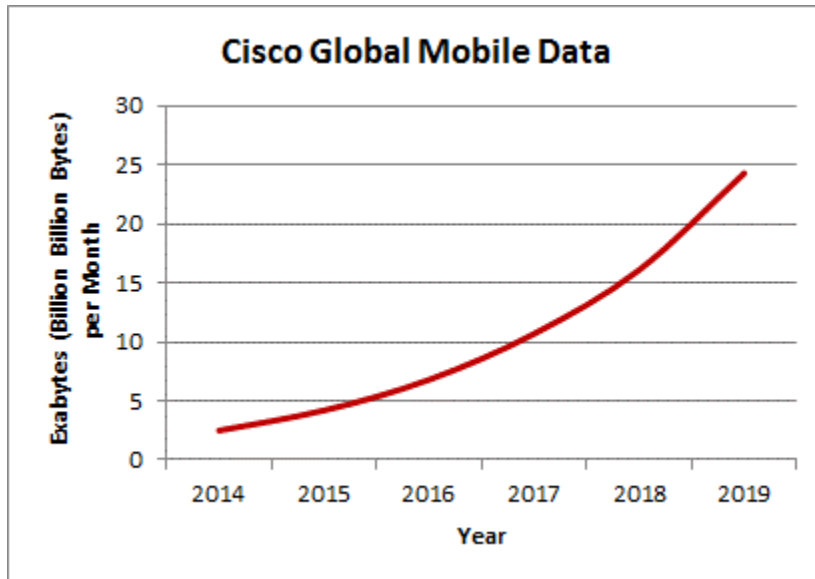
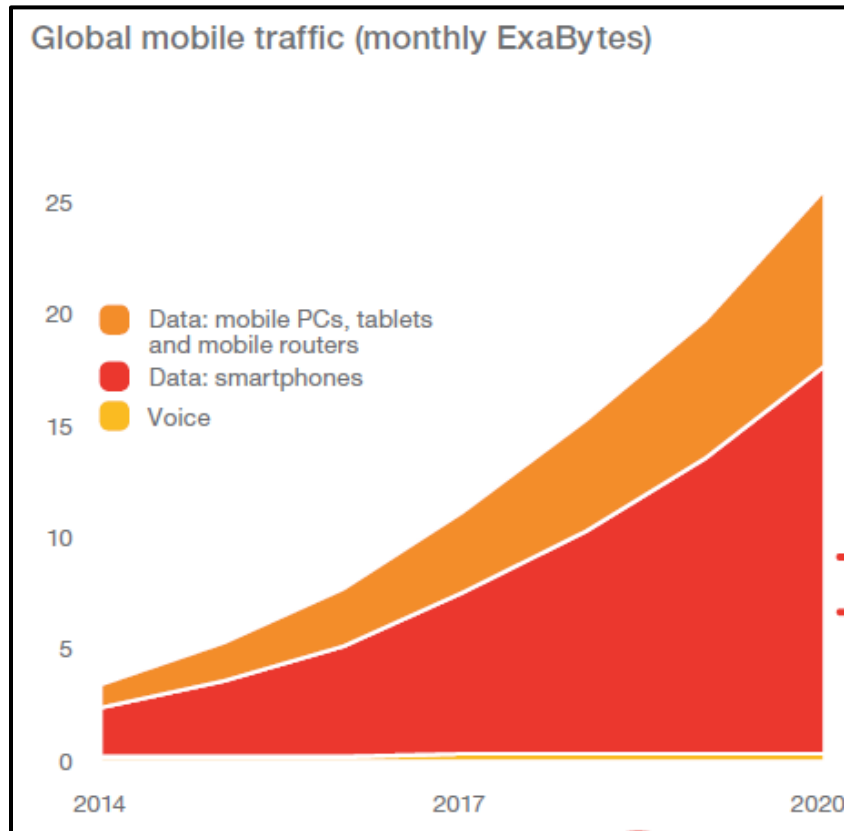

Figure 3 shows another data projection, predicting 40% annual growth in data for the 2014 to 2020 period, resulting in eight-fold growth.

---

<sup>4</sup> Cisco, *Cisco Visual Networking Index: Global Mobile Data Traffic Forecast Update, 2014-2019*, February 2015.

**Figure 3: Global Mobile Traffic for Voice and Data 2014 to 2020<sup>5</sup>**



In July 2015, more than 6.2 billion subscribers were using GSM-HSPA<sup>6</sup>—85% of the world’s 7.3 billion population.<sup>7</sup> By the end of 2019, the global mobile broadband market is expected to include nearly 8.45 billion subscribers, with 8.1 billion using 3GPP technologies, representing about 97% market share.<sup>8</sup> Chetan Sharma Consulting anticipates 2015 U.S. cellular data revenues to exceed \$132 billion, a growth of 22% over the prior year.<sup>9</sup>

The evolution of UMTS to HSPA has gained a worldwide customer base of more than two billion people on nearly 600 commercial networks.

LTE has experienced faster deployment than any mobile technology ever. All major U.S. operators now offer nationwide LTE coverage. LTE has also been chosen by U.S. national

---

<sup>5</sup> Ericsson, *Ericsson Mobility Report on the Pulse of the Networked Society*, February 2015.

<sup>6</sup> Ovum, July 2015.

<sup>7</sup> US Census Bureau, “U.S. and World Population Clock,” <http://www.census.gov/popclock/>, accessed June 25, 2015.

<sup>8</sup> Ovum, July 2015. Note that the 2018 mobile broadband market figures include GSM/EDGE, since most GSM networks are likely to include Evolved EDGE, which provides mobile broadband capability.

<sup>9</sup> Chetan Sharma, *US Mobile Data Market Update – Q1 2015*.

public-safety organizations as their broadband technology of choice. As shown in Figure 4, 2G GSM has peaked, and LTE subscriptions exceed CDMA. Both HSPA and LTE subscriptions will continue to rise through the rest of the decade.

**Figure 4: Global Adoption of 2G-4G Technologies 2010 to 2020<sup>10</sup>**

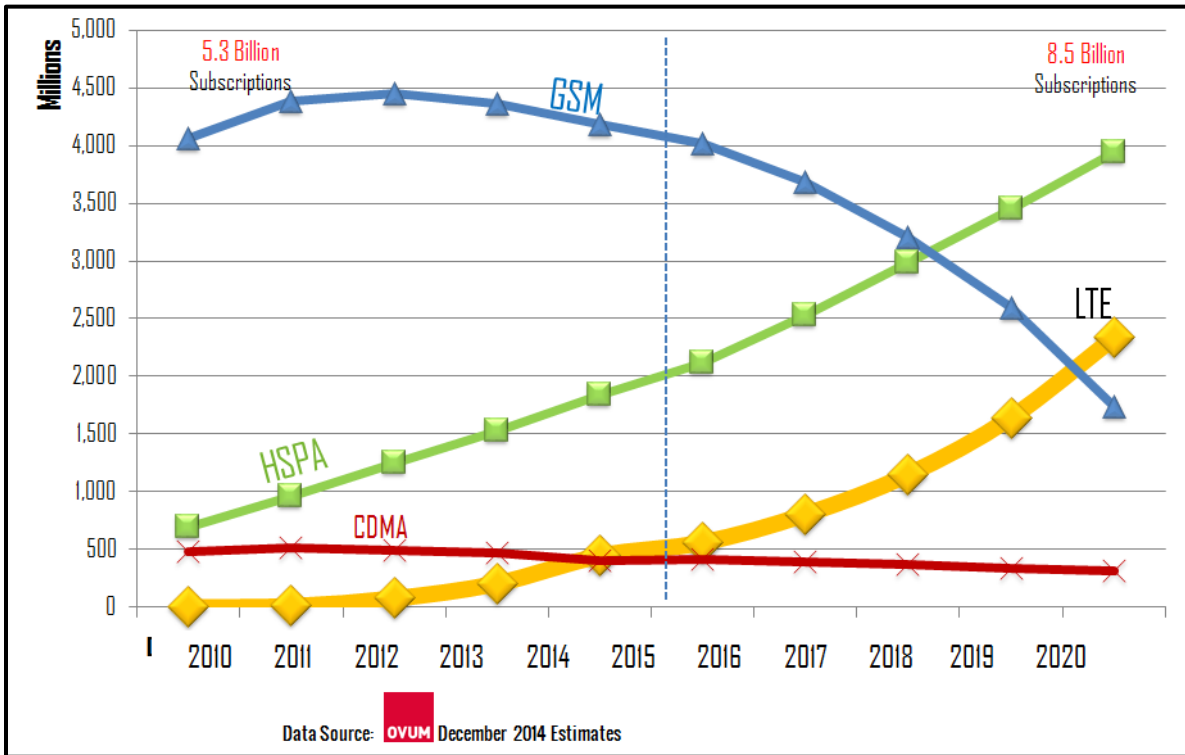

<sup>10</sup> 4G Americas Webinar, "The Future of Mobile Broadband in the Americas," Feb. 24, 2015.

## **The Path to 5G**

Mobile broadband, an ever-growing and highly visible component of the Internet, is impacting every aspect of life: changing how people socialize, how businesses operate, and how governments and their citizens interact. This section considers expanding use cases, the future of the Internet, 1G to 5G evolution, 5G concepts and architectures, and the capabilities defined in different releases of 3GPP specifications.

### ***Expanding Use Cases***

Many wireless technology discussions focus on radio capabilities, but other aspects that are just as important include use cases the technology supports, the services built on top of the technology, how different networks integrate with one another, and the topology of the networks. As summarized in Figure 5, all of these aspects are expanding, making mobile/wireless technology the foundation for other industries, including business-process optimization, consumer electronics, M2M, connected devices, and a multitude of vertical industries.

**Figure 5: Expanding Use Cases**

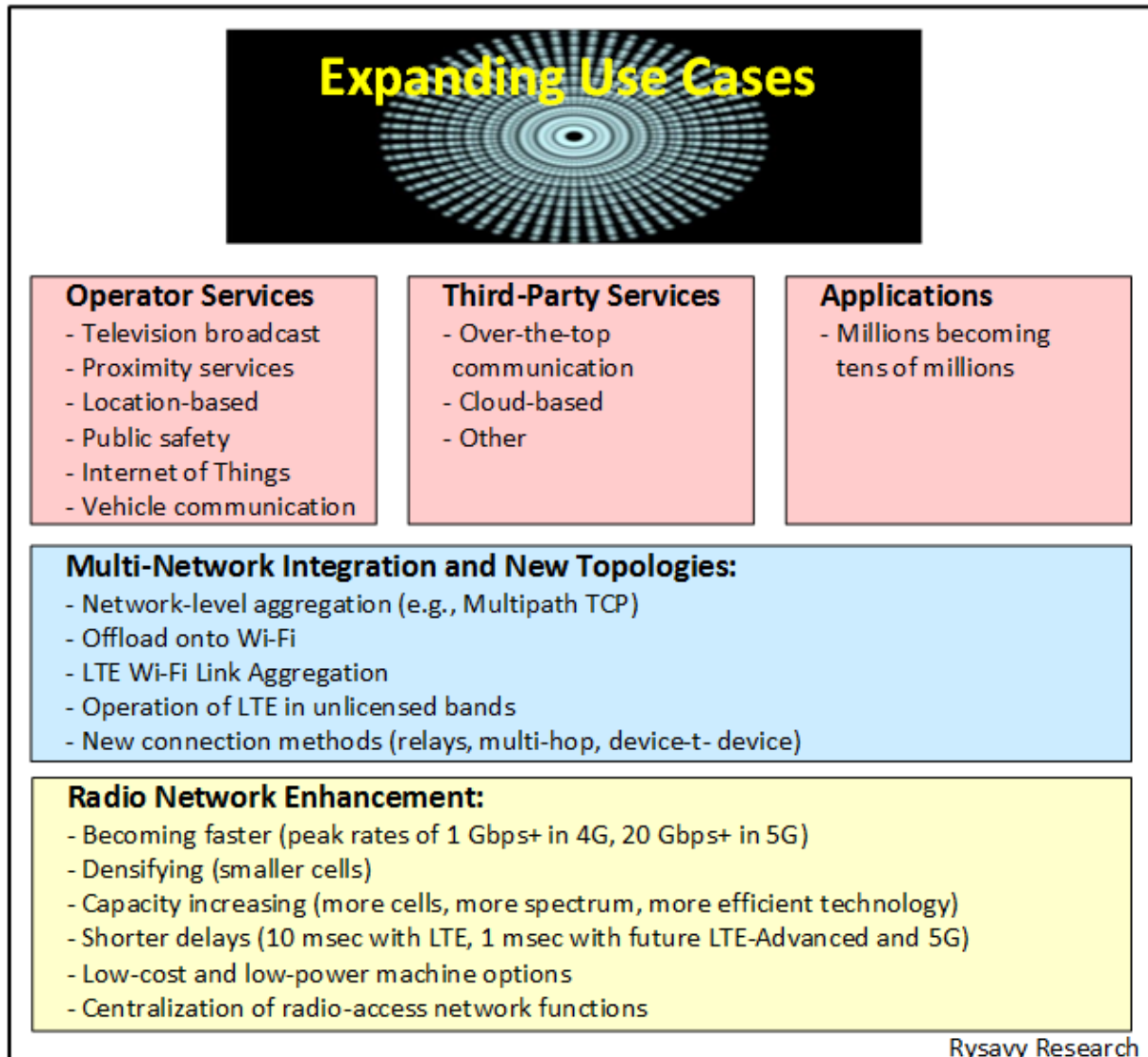

The result of these multi-dimensional developments are networks based on LTE-Advanced technology and eventually 5G networks that will be capable of:

- ❑ Extreme broadband of over 20 Gbps
- ❑ Capacity 100 to 10,000 times greater than today
- ❑ Deep coverage for machines buried within environments
- ❑ Extremely low energy demands for many years of battery operation
- ❑ Low complexity options for inexpensive machine communications
- ❑ Super-high density for both humans and machines
- ❑ Machine and automotive command-and-control



- ❑ Auto-awareness through discovery and self-optimization
- ❑ Continuous mobility and converged connectivity across multiple network types

## **1G to 5G Evolution**

The dawn of 5G looms over the industry, a dawn that will be constructed from millions of ideas, methods, algorithms, and processes. In some ways, 5G is a distraction from the intricate efforts to perfect 4G. Yet consumers keep demanding greater capabilities, and technology keeps advancing. So just as 4G LTE became available when previous technologies, such as HSPA, could be further improved, 5G enters the stage when the roadmap for LTE has not been exhausted. And just as 2G coexists today with 3G and 4G, 5G will coexist with previous generations of technology.

For historical context, "1G" refers to analog cellular technologies that became available in the 1980s. "2G" denotes initial digital systems that became available in the 1990s and that introduced services such as short messaging and lower-speed data. 3G requirements were specified by the ITU as part of the International Mobile Telephone 2000 (IMT-2000) project, for which digital networks had to provide 144 Kbps of throughput at mobile speeds, 384 Kbps at pedestrian speeds, and 2 Mbps in indoor environments. UMTS-HSPA and CDMA2000 are the primary 3G technologies. 3G technologies began to be deployed early last decade.

In 2008, the ITU issued requirements for IMT-Advanced, which many people initially used as a definition of 4G. Requirements included operation in up-to-40 MHz radio channels and extremely high spectral efficiency. The ITU required peak spectral efficiency of 15 bps/Hz and recommended operation in up-to-100 MHz radio channels, resulting in a theoretical throughput rate of 1.5 Gbps. In 2009 and 2010, the term "4G" became associated with mobile broadband technologies deployed at the time, such as HSPA+ and WiMAX. Today, 4G usually refers to HSPA+ or LTE.

Although the industry is preparing for 5G, LTE capabilities will continue to improve in LTE-Advanced through the rest of the decade. Many of these enhancements will come through incremental network investments. Given the scope of global wireless infrastructure, measured in hundreds of billions of dollars, offering users the most affordable service requires operators to leverage investments they have already made. 5G will eventually play an important role, but it must be timed appropriately so that the jump in capability justifies the new investment. Many of the features planned for 5G may in fact be implemented as LTE-Advanced extensions prior to full 5G availability.

5G groups researching next-generation wireless architecture and requirements include, among others, the International Telecommunication Union (ITU)<sup>11</sup>, the European Union's 5G Infrastructure Public-Private-Partnership (5G PPP), the METIS Consortium (Mobile and wireless communications Enablers for the Twenty-twenty Information Society), and Next Generation Mobile Networks (NGMN). Finally, 4G Americas is actively involved in

---

<sup>11</sup> International Telecommunication Union, "Working Party 5D (WP 5D) - IMT Systems," <http://www.itu.int/ITU-R/index.asp?category=study-groups&rlink=rwp5d&lang=en>, accessed March 19, 2015.

developing the vision and requirements of 5G for North, Central, and South America. 4G Americas has signed an MoU to collaborate with 5G-PPP.<sup>12</sup>

The ITU, the standardization group of the United Nations, has set the following standardization timetable in its IMT-2020 project:<sup>13</sup>

- ❑ 2016-2017: Definition of technical performance requirements, evaluation criteria and methods, and submission templates.
- ❑ 2018-2019: Submission of proposals.
- ❑ 2019: Evaluation of proposed technologies.
- ❑ 2020: Publication of IMT-2020 specifications.

Wireless technology has progressed to the extent that significant new capabilities are inevitable, making 5G a possible alternative to wireline broadband for many subscribers.<sup>14</sup>

Table 2 summarizes the generations of wireless technology.

**Table 2: 1G to 5G**

Generation	Requirements	Comments
<b>1G</b>	No official requirements. Analog technology.	Deployed in the 1980s.
<b>2G</b>	No official requirements. Digital technology.	First digital systems. Deployed in the 1990s. New services such as SMS and low-rate data. Primary technologies include IS-95 CDMA (cdmaOne) and GSM.
<b>3G</b>	ITU’s IMT-2000 required 144 Kbps mobile, 384 Kbps pedestrian, 2 Mbps indoors	First deployment in 2000. Primary technologies include CDMA2000 1X/EV-DO and UMTS-HSPA.

<sup>12</sup> 5GPPP, “5G-PPP MoU with 4G Americas,” March 2, 2015. <http://5g-ppp.eu/5g-ppp-mou-with-4g-americas/>

<sup>13</sup> ITU, “ITU towards ‘IMT for 2020 and beyond’,” <http://www.itu.int/en/ITU-R/study-groups/rsg5/rwp5d/imt-2020/Pages/default.aspx>, viewed July 7, 2015.

<sup>14</sup> Rysavy Research, “How will 5G compare to fiber, cable or DSL?” Fierce Wireless, May 2014. Available at <http://www.rysavy.com/Articles/2014-05-5G-Comparison-Wireline.pdf>.

Generation	Requirements	Comments
		WiMAX.
<b>4G (Initial Technical Designation)</b>	ITU's IMT-Advanced requirements include ability to operate in up to 40 MHz radio channels and with very high spectral efficiency.	First deployment in 2010.  IEEE 802.16m and LTE-Advanced meet the requirements.
<b>4G (Current Marketing Designation)</b>	Systems that significantly exceed the performance of initial 3G networks. No quantitative requirements.	Today's HSPA+, LTE, and WiMAX networks meet this requirement.
<b>5G</b>	ITU IMT-2020 requirements are in progress and may represent initial technical requirements for 5G.	Expected in 2020 timeframe.  Term applied to generation of technology that follows LTE-Advanced.

The interval between each significant technology platform has been about ten years. Within each platform, however, there is constant innovation. For example, with 2G technology, EDGE significantly improved data performance compared with initial General Packet Radio Service (GPRS) capabilities. Similarly, HSPA hugely increased data speeds compared with initial 3G capabilities. LTE and LTE-Advanced are also acquiring continual improvements that include both faster speeds and greater efficiency.

Figure 6 presents the timeline of technology generations, including past and future, showing initial deployment, the year of the peak number of subscribers, and decline. Each cellular generation spans multiple decades, with peak adoption occurring some 20 years after initial deployment. 6G deployment in 2030, though highly speculative, is consistent with deployment of previous generations.

**Figure 6: Timeline of Cellular Generations**

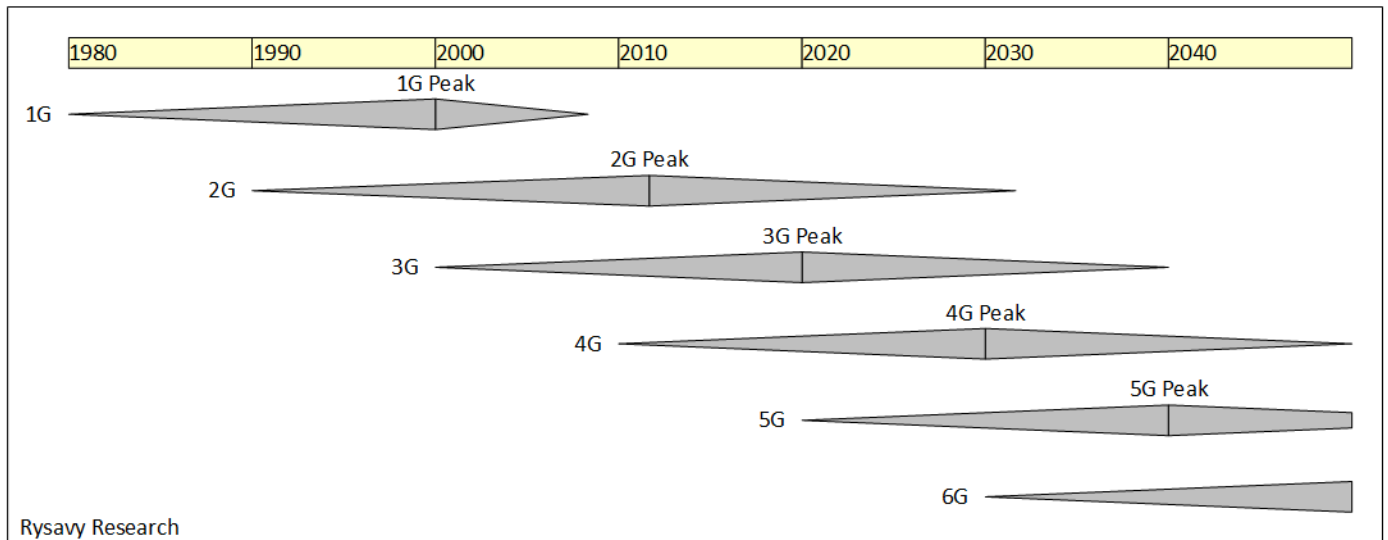

## **5G Concepts and Architectures**

Standards bodies have not yet defined 5G requirements, but various groups are discussing the possibilities of what might constitute 5G for network deployments in 2020 or beyond. Under debate is whether 5G should be evolutionary from LTE or revolutionary, such as implementing a completely new radio interface or even multiple new radio interfaces. Regardless, commonly stated goals of 5G include the following:

- ❑ Data rates of 20 Gbps or higher, at least ten times higher than 4G.
- ❑ 100 Mbps throughputs even under heavy load and at the cell edge.
- ❑ More uniform user experience across the coverage area.
- ❑ Extremely low latency, 1 msec or less, ten times lower than 4G, enabling greater real-time control of systems.
- ❑ Using high frequencies, above 5 GHz and including mmWave (30 GHz and higher GHz).
- ❑ Wide radio channels, 1 to 2 GHz, or even wider.
- ❑ Hierarchical/planned and ad hoc deployment models.
- ❑ Use of licensed and unlicensed bands.
- ❑ Equal support for human-type and machine-type communications. Includes highly efficient small-data transmission.
- ❑ Advanced spectrum sharing.

Figure 7 shows the transformation of networks, moving from today's LTE-Advanced networks to future LTE-Advanced and eventually 5G networks.

**Figure 7: Network Transformation<sup>15</sup>**

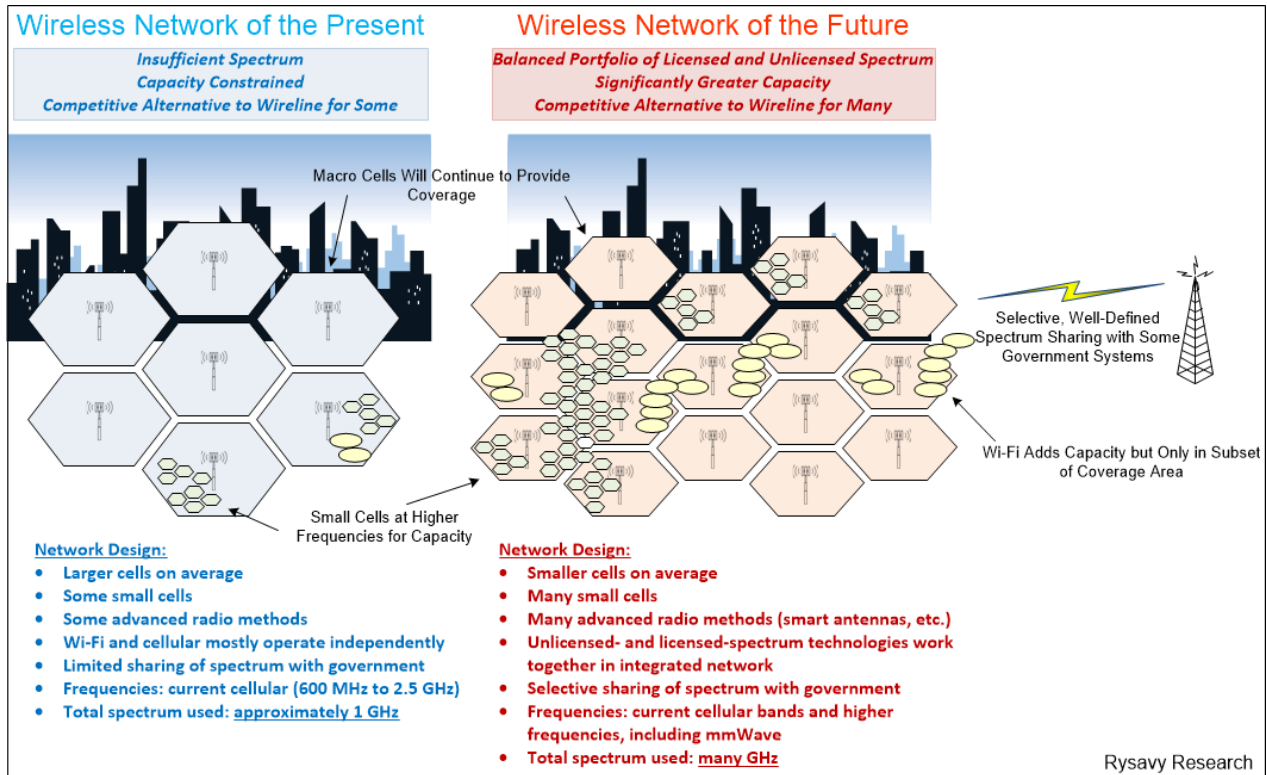

The fundamental decision for 5G is how to best leverage existing technology investments in LTE while exploiting new spectrum and new technology capabilities. 5G design emphasizes ways to combine existing 4G LTE networks with capabilities provided by 5G. One such approach is to use enhanced LTE in existing frequency bands and to provide interworking with access in new bands that span a wide range of frequencies, as shown in Figure 8.

<sup>15</sup> See also Rysavy Research infographic, “Mobile Broadband Networks of the Future,” April 2014. Available at <http://www.rysavy.com/Articles/2014-05-Networks-of-the-Future-Infographic.pdf>.

**Figure 8: 5G Combining of LTE and New Radio Technologies**

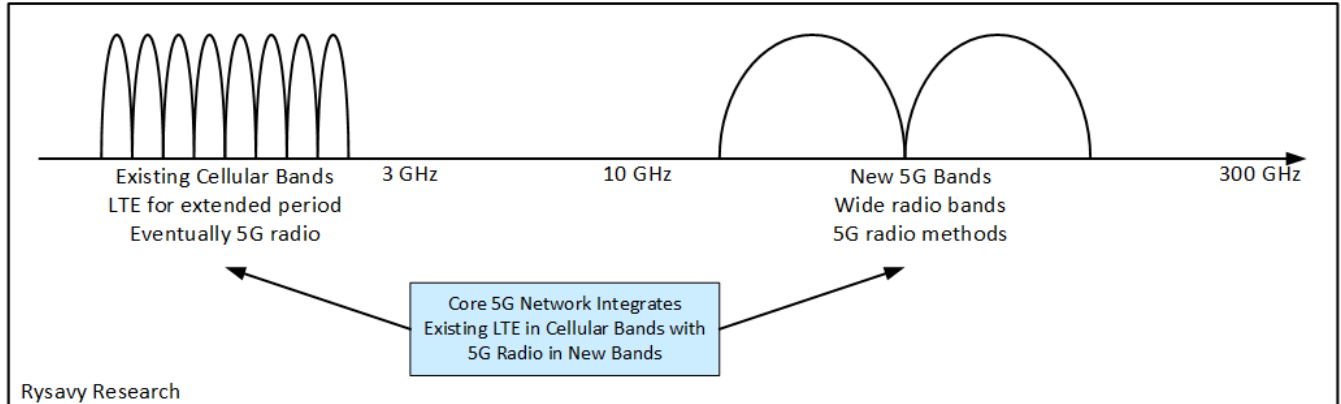

One decision of 5G is whether to use LTE-like radio access in new 5G bands or to instead invent new radio-access technologies, as shown in Figure 9. New radio methods would boost performance and could co-exist with future versions of LTE.

**Figure 9: Evolution to 5G Including LTE Improvements and Potential New 5G Radio Methods**

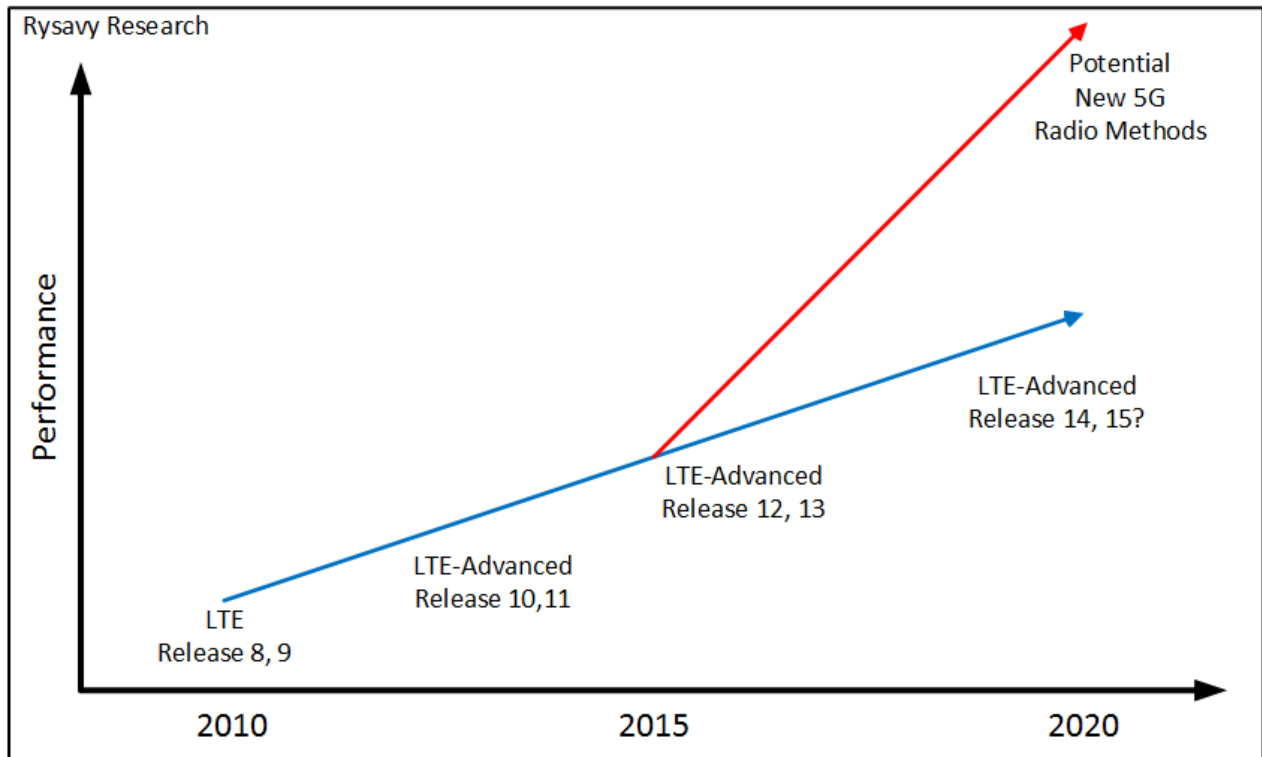

With the mindset of leveraging LTE investments and providing interoperability with LTE networks while increasing performance, the specific technologies designers are evaluating for 5G include the items explained in Table 3:

**Table 3: Key 5G Technology Elements under Investigation**

Key 5G Technology Element	Description	Benefit
Massive MIMO	Extension of MIMO concept to hundreds of antennas at the base station.	Increase of spectral efficiency, at least doubling, with 5X to 10X gains theorized.
10 GHz or higher bands	Most cellular today is below 3 GHz, but new technology allows operation in 10 GHz to 100 GHz for small cells.	Vast new spectrum amounts available (as much as 10X or more) as well as wider radio channels (1 or 2 GHz) enabling much higher data rates.
New multi-carrier radio transmission	LTE uses OFDM, but other potential multi-carrier schemes include Filter-Bank Multi-Carrier (FBMC) transmission, Universal Filtered Multi-Carrier (UFMC) transmission, and Generalized Frequency-Division Multiplexing (GFDM).	Lower latency on uplink transmission due to lower synchronization requirements.  Potentially better suited for spectrum sharing because the transmission operates in more confined spectrum.
Non-Orthogonal Multiple Transmission	Orthogonality in OFDM avoids interference and creates high capacity, but requires extensive signaling and increases delay.  Non-Orthogonal Multiple Access (NOMA) and Sparse Coded Multiple Access (SCMA) could complement orthogonal access by taking advantage of advanced interference-cancellation techniques.	Reduced latency for small payloads.
Shared Spectrum Access	Current LTE systems assume dedicated spectrum.  Future wireless systems (LTE and 5G) will interface with planned Spectrum Access Systems that manage spectrum among primary (incumbent, e.g., government), secondary (licensed, e.g., cellular), and tertiary (unlicensed) users.	More efficient use of spectrum for scenarios in which incumbents use spectrum lightly.
Advanced Inter-Node Coordination	LTE already uses techniques such as inter-cell interference coordination and Coordinated Multi-Point.  In 5G, cloud RANs will enable better coordination across base stations.	Higher network capacity.

Key 5G Technology Element	Description	Benefit
Simultaneous Transmission Reception	<p>Current cellular systems cannot transmit and receive simultaneously in the exact same spectrum.</p> <p>By using advanced interference cancellation methods, future systems could potentially do so, especially in low-power transmission environments such as small cells.</p>	Doubling of capacity. Potential improvements in radio-access control.
Multi-Radio-Access-Technologies	<p>LTE already integrates with Wi-Fi, and plans include operation in unlicensed spectrum.</p> <p>5G will need to integrate even more tightly with Wi-Fi, 4G, and 3G systems. Virtualization methods may facilitate such integration by enabling instantiation of network functions on demand.</p>	Users automatically obtain the most suitable network based on their requirements and network loads.
Device-to-Device Communication	<p>LTE already includes a limited form of device-to-device communication.</p> <p>5G could use this form of communication to extend coverage and to transfer the same data to multiple units more efficiently.</p>	More efficient network use and improved access to data for users.
Wireless Access/Backhaul Integration	<p>Today, wireless backhaul and access are based on different technologies.</p> <p>5G could be designed to handle both functions, essentially making the wireless link a multi-hop network.</p>	Greater flexibility in deploying dense networks.
Flexible Networks	<p>Network function virtualization is becoming common in LTE.</p> <p>5G will be fully virtualized based on NFV and software-defined networking.</p>	Lower deployment and operating costs. Faster rollout of new services.

Of the technology elements above, use of higher frequencies, such as above 10 GHz, represents the greatest opportunity for higher throughputs and higher capacity. This benefit derives from the potential availability of ten times the amount of spectrum as is currently available, with multiple GHz of contiguous spectrum. But these higher frequencies, especially mmWave frequencies (above 30 GHz), are suitable only over short distances. The combination of lower and higher frequencies is therefore crucial for 5G



operation. Lower bands could be devoted to coverage and control, while higher bands could provide opportunistic access for high data rates. The lower and higher spectrum bands could operate in a carrier-aggregation mode.

Despite providing huge potential capacity gains, mmWave frequencies suffer from worse propagation characteristics, even in line-of-sight conditions, compared with lower frequencies. This effect comes about because the comparatively smaller aperture area of the receiver's antenna requires some form of beamforming at the transmit side, and potentially even at the receiver side. Fortunately, the smaller form factors of mmWave antennas allows for dense packing of antenna arrays. Experimental systems using antenna arrays have demonstrated reliable communications at 28 GHz, even in dense, urban, non-line-of-sight conditions, for distances up to 200 meters.<sup>16</sup> Arrays at the terminal side are space-constrained, but some basic beamforming at the terminal is possible. On the base station side, the arrays may include hundreds of antennas in an approach called "massive MIMO."

Other technical approaches researchers are investigating in conjunction with 5G include flexible mobility, context-aware networking, and moving networks.<sup>17</sup>

## ***Information-Centric Networking***

For many usage scenarios, wireless networks provide broadband access to the Internet, a network that itself is evolving. The Internet is based on a node-centric design developed forty years ago. The point-to-point method of communication the Internet uses has functioned well for a vast array of applications but is not optimal for the way content is developed and distributed today. Industry and academic organizations are researching a concept called Information-Centric Networking. ICN seeks a new approach of in-network caching that distributes content on a large scale, cost-efficiently and securely.

Most Internet content uses Uniform Resource Identifiers (URIs) to locate objects and define specific location-dependent IP addresses. This approach, however, causes problems when content moves, sites change domains, or content is replicated and each copy appears as a different object. Developments such as peer-to-peer overlays and content distribution networks (such as Akamai) that distribute cached copies of content are a first step toward an information-centric communication model.

ICN is built from the ground up on the assumption of mobility, so it eliminates the mobility overlays on which current mobile broadband networks depend. The approach will be able to place information anywhere in the network with immediate and easy retrieval.

Key principles of ICN include:

- ❑ The architecture inherently supports user mobility.
- ❑ Network operations are name based instead of address- or node-based.
- ❑ The network itself stores, processes, and forwards information.

---

<sup>16</sup> Samsung, *5G Vision*, February 2015. Available at <http://www.samsung.com/global/business-images/insights/2015/Samsung-5G-Vision-0.pdf>.

<sup>17</sup> For more details, refer to *4G Americas' Recommendations on 5G Requirements and Solutions*, October 2014.

- Intrinsic security guarantees the integrity of every data object.

The goal of ICN is to simplify the storage and distribution of gigantic amounts of content while reducing the amount of traffic and latency users face when accessing the content. The Internet cannot just be replaced, however, so in initial stages, ICN would operate as an overlay, and over time would assume an increasing percentage of the functions within the Internet. ICN would not discard IP; rather it seeks to generalize the routing concept to enrich networking with new capabilities.

Because mobility is such a central aspect of ICN, mobile network operators are in a unique position to participate in ICN-related research and development, and to do so as part of 5G development.

### **3GPP Releases**

3GPP standards development falls into three principal areas: radio interfaces, core networks, and services. Progress in the 3GPP family of technologies has occurred in multiple phases, first with GSM, then GPRS, EDGE, UMTS, HSPA, HSPA+, LTE, and now LTE-Advanced. Underlying radio approaches have evolved from Time Division Multiple Access (TDMA) to CDMA to Orthogonal Frequency Division Multiple Access (OFDMA), which is the basis of LTE. 3GPP will also be involved in standardization of 5G technology.

LTE incorporates best-of-breed radio techniques to achieve performance levels beyond what may be practical with some CDMA approaches, particularly in larger channel bandwidths. In the same way that 3G coexists with 2G systems in integrated networks, LTE systems coexist with both 3G and 2G systems, with devices capable of 2G, 3G, and 4G modes. Beyond radio technology, the Evolved Packet Core (EPC) provides a new core architecture that is flatter and integrates with both legacy GSM-HSPA networks and other wireless technologies, such as CDMA2000 and Wi-Fi. The combination of EPC and LTE is referred to as the Evolved Packet System (EPS).

The cost for operators to deliver data (for example, cost per GB) is almost directly proportional to the spectral efficiency of the technologies in use. LTE has the highest spectral efficiency of any specified technology to date.

As competitive pressures in the mobile broadband market intensify, and as demand for capacity persistently grows, LTE has become the favored 4G solution because of its high data throughputs, low latency, and high spectral efficiency. Specifically:

- **Wider Radio Channels.** LTE can be deployed in wide radio channels (for example, 10 MHz or 20 MHz) with carrier aggregation up to 100 MHz. This increases peak data rates and uses spectrum more effectively.
- **Easiest MIMO Deployment.** By using new radios and antennas, LTE facilitates MIMO deployment, in contrast to the logistical challenges of adding antennas for MIMO to existing legacy technologies. Furthermore, MIMO gains are maximized because all user equipment supports it from the beginning.
- **Best Latency Performance.** For some applications, low latency (packet traversal delay) is as important as high throughput. With a low transmission-time interval (TTI) of 1 millisecond (msec) and a flat architecture (fewer nodes in the core network), LTE has the lowest latency of any cellular technology.

LTE is available in both Frequency Division Duplex (FDD) and Time Division Duplex (TDD) modes. Many deployments will be based on FDD in paired spectrum. The TDD mode,

however, is important for deployments in which paired spectrum is unavailable. Instances of TDD deployment include China, Europe at 2.6 GHz, U.S. Broadband Radio Service (BRS) spectrum at 2.6 GHz, and the forthcoming 3.5 GHz small-cell band.

The versions of LTE most widely deployed today (Releases 8 through 10) are just the first in a series of innovations that will increase performance, efficiency, and capabilities. Enhancements in the 2013 to 2016 period are the ones defined in 3GPP Releases 10, 11, and 12 and are commonly referred to as LTE-Advanced.<sup>18</sup> Subsequent releases, such as Releases 13 and 14, will continue innovating through the end of this decade.

The following list ranks the most important features of LTE-Advanced:

1. **Carrier Aggregation.** Already in use, operators can aggregate radio carriers in the same band or across disparate bands to improve throughputs (under light network load), capacity, and efficiency. Carrier aggregation can also combine FDD and TDD, as well as licensed and unlicensed bands. As examples, in 2015, AT&T had aggregated 700 MHz with AWS, and 700 MHz with PCS. T-Mobile had aggregated 700 MHz with AWS, and AWS with PCS.<sup>19</sup> By 2016, three-carrier aggregation may occur, and eventually operators may aggregate four carriers.<sup>20</sup>
2. **Coordinated Multi Point.** Expected in the 2015-2016 timeframe, CoMP is a process by which multiple base stations or cell sectors process a UE signal simultaneously, or coordinate the transmissions to a UE, improving cell-edge performance and network efficiency. Initial usage will be on the uplink because no changes are required to user equipment (UE).
3. **HetNet Support.** Also expected in the 2015-2016 timeframe, HetNets integrate macro cells and small cells. A key feature is enhanced intercell interference coordination (eICIC), which enhances the ability of a macro and a small cell to use the same spectrum. This approach is valuable when the operator cannot dedicate spectrum to small cells. Operators are currently evaluating eICIC, and at least one operator has deployed it.<sup>21</sup>
4. **Self-Organizing Networks.** With SON, networks can automatically configure and optimize themselves, a capability that will be particularly important as small cells begin to proliferate. Vendor-specific methods are common for 3G networks, and trials are now occurring for 4G LTE standards-based approaches.

The appendix explains these features and quantifies performance gains, and Figure 10 illustrates the transition from LTE to LTE-Advanced, which includes these features.

---

<sup>18</sup> From a strict standards-development point of view, the term "LTE-Advanced" refers to the following features: carrier aggregation, 8X8 downlink MIMO, and 4XN uplink MIMO with N the number of receive antennas in the base station.

<sup>19</sup> AT&T band combinations are 3GPP Band 13 + Band 4, Band 17 + Band 4, and Band 17 + Band 2. T-Mobile band combinations are Band 12 + Band 4, Band 12 + Band 2, and Band 4 + Band 2.

<sup>20</sup> For carrier aggregation to operate, both the network and the device have to support the particular band combination. Legacy devices typically do not support new network aggregation capabilities.

<sup>21</sup> Fierce Wireless, "SK Telecom teams with Nokia Networks on eICIC," January 2015.

**Figure 10: LTE to LTE-Advanced Migration**

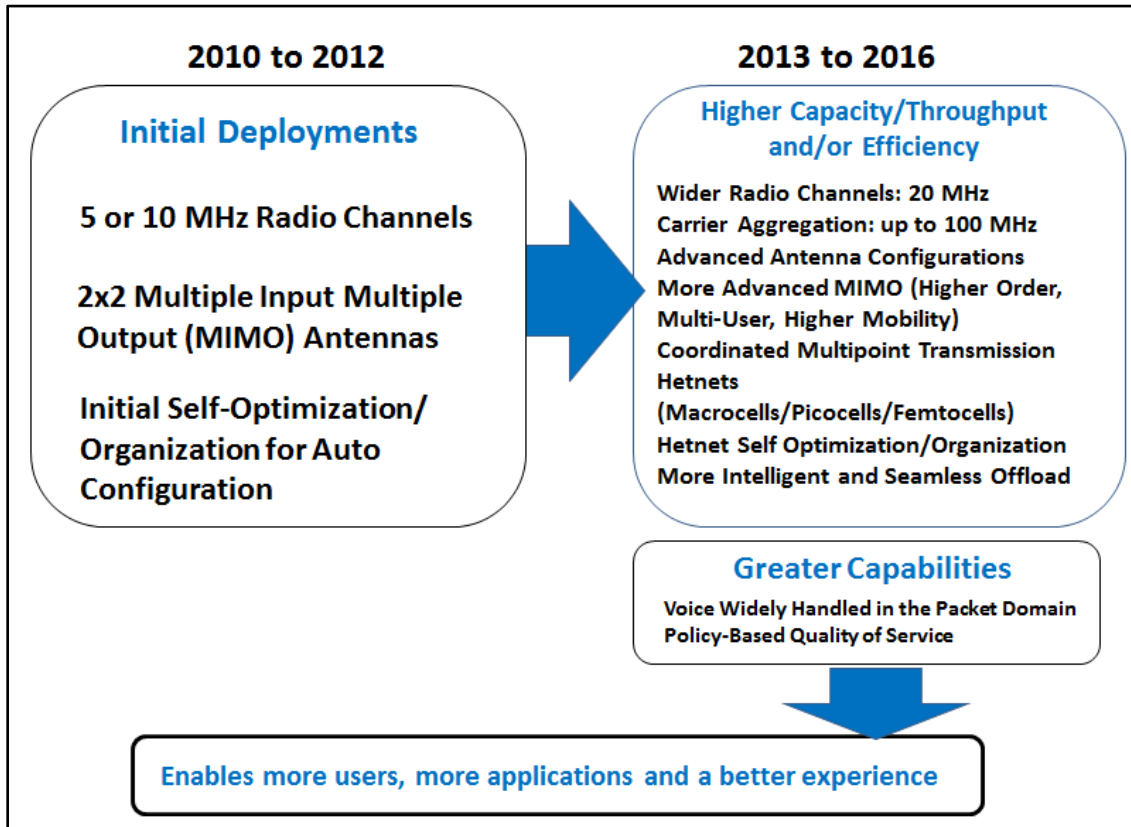

Table 4 summarizes the key 3GPP technologies and their characteristics.

**Table 4: Characteristics of 3GPP Technologies**

Technology Name	Type	Characteristics	Typical Downlink Speed	Typical Uplink Speed
HSPA <sup>22</sup>	WCDMA	Data service for UMTS networks. An enhancement to original UMTS data service.	1 Mbps to 4 Mbps	500 Kbps to 2 Mbps

<sup>22</sup> HSPA and HSPA+ throughput rates are for a 5+5 MHz deployment.

Technology Name	Type	Characteristics	Typical Downlink Speed	Typical Uplink Speed
HSPA+	WCDMA	Evolution of HSPA in various stages to increase throughput and capacity and to lower latency.	1.9 Mbps to 8.8 Mbps in 5+5 MHz <sup>23</sup> 3.8 Mbps to 17.6 Mbps with dual carrier in 10+5 MHz	1 Mbps to 4 Mbps in 5+5 MHz or in 10+5 MHz
LTE	OFDMA	New radio interface that can use wide radio channels and deliver extremely high throughput rates. All communications handled in IP domain.	6.5 to 26.3 Mbps in 10+10 MHz <sup>24</sup>	6.0 to 13.0 Mbps in 10+10 MHz
LTE-Advanced	OFDMA	Advanced version of LTE designed to meet IMT-Advanced requirements.	Significant gains through carrier aggregation	

User achievable rates and additional details on typical rates are covered in the appendix section "Data Throughput." Figure 11 shows the evolution of different wireless technologies and their peak network performance capabilities.

---

<sup>23</sup> "5+5 MHz" means 5 MHz used for the downlink and 5 MHz used for the uplink.

<sup>24</sup> 4G Americas member company analysis for downlink and uplink. Assumes single user with 50% load in other sectors. AT&T and Verizon are quoting typical user rates of 5-12 Mbps on the downlink and 2-5 Mbps on the uplink for their networks. See additional LTE throughput information in the section below, "LTE Throughput."

**Figure 11: Evolution of CDMA and OFDMA Systems**

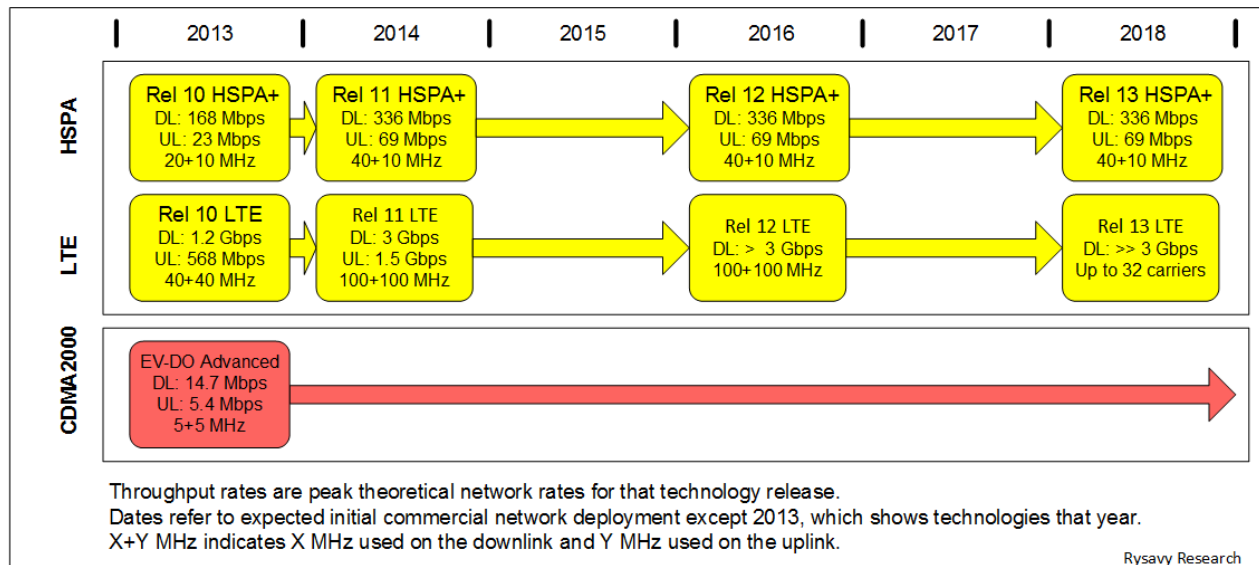

The development of GSM and UMTS-HSPA happens in stages corresponding to 3GPP specification releases, with each release addressing multiple technologies. For example, Release 8 defined dual-carrier operation for HSPA but also introduced LTE. A summary of the different 3GPP releases is as follows:<sup>25</sup>

- ❑ **Release 99:** Completed. First deployable version of UMTS. Enhancements to GSM data (EDGE). Majority of deployments today are based on Release 99. Provides support for GSM/EDGE/GPRS/WCDMA radio-access networks.
- ❑ **Release 4:** Completed. Multimedia messaging support. First steps toward using IP transport in the core network.
- ❑ **Release 5:** Completed. HSDPA. First phase of Internet Protocol Multimedia Subsystem (IMS). Full ability to use IP-based transport instead of just Asynchronous Transfer Mode (ATM) in the core network.
- ❑ **Release 6:** Completed. HSUPA. Enhanced multimedia support through Multimedia Broadcast/Multicast Services (MBMS). Performance specifications for advanced receivers. Wireless Local Area Network (WLAN) integration option. IMS enhancements. Initial VoIP capability.
- ❑ **Release 7:** Completed. Provides enhanced GSM data functionality with Evolved EDGE. Specifies HSPA+, which includes higher order modulation and MIMO. Performance enhancements, improved spectral efficiency, increased capacity, and better resistance to interference. Continuous Packet Connectivity (CPC) enables efficient “always-on” service and enhanced uplink UL VoIP capacity, as well as reductions in call set-up delay for Push-to-Talk Over Cellular (PoC). Radio enhancements to HSPA include 64 Quadrature Amplitude Modulation (QAM) in the

<sup>25</sup> After Release 99, release versions went to a numerical designation instead of designation by year.

downlink and 16 QAM in the uplink. Also includes optimization of MBMS capabilities through the multicast/broadcast, single-frequency network (MBSFN) function.

- ❑ **Release 8:** Completed. Comprises further HSPA Evolution features such as simultaneous use of MIMO and 64 QAM. Includes dual-carrier HSDPA (DC-HSDPA) wherein two downlink carriers can be combined for a doubling of throughput performance. Specifies OFDMA-based 3GPP LTE. Defines EPC and EPS.
- ❑ **Release 9:** Completed. HSPA and LTE enhancements including HSPA dual-carrier downlink operation in combination with MIMO, Multimedia Broadcast Multicast Services (MBMS), HSDPA dual-band operation, HSPA dual-carrier uplink operation, EPC enhancements, femtocell support, support for regulatory features such as emergency user-equipment positioning and Commercial Mobile Alert System (CMAS), and evolution of IMS architecture.
- ❑ **Release 10:** Completed. Specifies LTE-Advanced that meets the requirements set by ITU's IMT-Advanced project. Key features include carrier aggregation, multi-antenna enhancements such as enhanced downlink eight-branch MIMO and uplink MIMO, relays, enhanced LTE Self-Organizing Network capability, Evolved Multimedia Broadcast Multicast Services (eMBMS), HetNet enhancements that include eICIC, Local IP Packet Access, and new frequency bands. For HSPA, includes quad-carrier operation and additional MIMO options. Also includes femtocell enhancements, optimizations for M2M communications, and local IP traffic offload.
- ❑ **Release 11:** Completed. For LTE, emphasis is on Coordinated Multi Point (CoMP), carrier-aggregation enhancements, devices with interference cancellation, development of the Enhanced Physical Downlink Control Channel (EPDCCH), and further enhanced eICIC including devices with CRS (Cell-specific Reference Signal) interference cancellation. The release includes further DL and UL MIMO enhancements for LTE. For HSPA, provides eight-carrier on the downlink, uplink enhancements to improve latency, dual-antenna beamforming and MIMO, CELL\_Foward Access Channel (FACH) state enhancement for smartphone-type traffic, four-branch MIMO enhancements and transmissions for HSDPA, 64 QAM in the uplink, downlink multipoint transmission, and noncontiguous HSDPA carrier aggregation. Wi-Fi integration is promoted through S2a Mobility over GPRS Tunneling Protocol (SaMOG). An additional architectural element called Machine-Type Communications Interworking Function (MTC-IWF) will more flexibly support machine-to-machine communications.
- ❑ **Release 12:** Completed. Enhancements include improved small cells/HetNets for LTE, LTE multi-antenna/site technologies (including Active Antenna Systems), Dual Connectivity, 256 QAM modulation option, further CoMP/MIMO enhancements, enhancements for interworking with Wi-Fi, enhancements for MTC, SON, support for emergency and public safety, Minimization of Drive Tests (MDT), advanced receivers, device-to-device communication (also referred to as proximity services), group communication enablers in LTE, addition of Web Real Time Communication (WebRTC) to IMS, energy efficiency, more flexible carrier aggregation, dynamic adaptation of uplink-downlink ratios in TDD mode, further enhancements for HSPA+, small cells/HetNets, Scalable-UMTS, and FDD-TDD carrier aggregation.
- ❑ **Release 13:** Some of the items under consideration include radio-access network sharing, 32-carrier aggregation, License Assisted Access (LAA), LTE Wi-Fi Aggregation (LWA), isolated operation for public safety, application-specific congestion management, user-plane congestion management, enhancement to WebRTC

interoperability, architecture enhancement for dedicated core networks, enhancement to proximity-based services, mission-critical push-to-talk, group communications, CoMP enhancements, small cell enhancements, machine-type communications enhancements, VoLTE enhancements, SON enhancements, shared network enhancements, and enhanced circuit-switched fallback.

3GPP has not yet determined which release of specifications may include 5G specifications. The tentative 3GPP timeline for 5G states, "In particular no assumptions are made concerning: The number and exact timing of 3GPP Releases encompassing the IMT2020 submission schedule; When & in which release there will be the first set of "5G" specs and what will be the target content."<sup>26</sup>

---

<sup>26</sup> 3GPP, "Tentative 3GPP timeline for 5G," [http://www.3gpp.org/news-events/3gpp-news/1674-timeline\\_5g](http://www.3gpp.org/news-events/3gpp-news/1674-timeline_5g), viewed May 22, 2015.



# Supporting Technologies and Architectures

Network architects design networks using a deep and wide toolkit, including multiples types of cell sizes, integration with unlicensed spectrum, smart antennas, converged services, and virtualization.

## *Types of Cells*

Operators have many choices for providing coverage. Lower frequencies propagate further and thus require fewer cells for coverage. The resulting network, however, has lower capacity than one with more cells, so operators have to continually evaluate cell placement with respect to both coverage and capacity.

Table 5 lists the available choices. Note that the distinctions, such as radius, are not absolute—perhaps one reason the term “small cell” has become popular, as it encompasses picocells, microcells, femtocells, and sometimes Wi-Fi.

With “plug-and-play” capability derived from self-organizing and self-organizing features, small cells will increasingly be deployed in an ad hoc manner, anywhere power and backhaul are available, yet will operate in tight coordination with the rest of the network.

A proliferation of small cells inside buildings will also provide coverage from inside to outside, such as in city streets, the reverse of traditional coverage that extends from outdoor cells to inside.

Extremely dense outdoor deployments could reach 1,000 cells per square kilometer.

**Table 5: Types of Cells and Typical Characteristics (Not Formally Defined)**

Type of Cell	Characteristics
Macro cell	Wide-area coverage. LTE supports cells up to 100 km in range, but typical distances are .5 to 5 km radius. Always installed outdoors.
Microcell	Covers a smaller area, such as a hotel or mall. Range to 2 km, 5-10W, and 256-512 users. Usually installed outdoors.
Picocell	Indoor or outdoor. Outdoor cells also called “microcells.” Typical range 15 to 200 meters outdoors and 10 to 25 meters indoors, 1-2W, 64-128 users. Deployed by operators primarily to expand capacity.
Consumer Femtocell	Indoors. Range to 10 meters, less than 50 mW, and 4 to 6 users. Capacity and coverage benefit. Usually deployed by end users using their own backhaul.
Enterprise Femtocell	Indoors. Range to 25 meters, 100-250 mW, 16-32 users. Capacity and coverage benefit. Deployed by operators.
Distributed antenna system.	Expands indoor or outdoor coverage. Same hardware can support multiple operators (neutral host) since antenna can support broad frequency range and multiple technologies. Indoor deployments are typically in larger spaces such as

Type of Cell	Characteristics
	airports. Has also been deployed outdoors for coverage and capacity expansion.
Remote radio head (RRH)	Uses baseband at existing macro site or centralized baseband equipment. If centralized, the system is called "cloud RAN." Requires fiber connection.
Wi-Fi	Primarily provides capacity expansion. Neutral-host capability allows multiple operators to share infrastructure.
"Super Wi-Fi"	Name used by some people for white-space technology. Not true Wi-Fi. Better suited for fixed wireless than mobile wireless.

## ***Smalls Cells and Heterogeneous Networks***

Historically, increasing the number of cell sites has been the primary method for increasing capacity, providing gains far greater than what can be achieved by improvements in spectral efficiency alone. The next wave of densification is by using what the industry calls "small cells."

Central to small-cell support is the heterogeneous network architecture, with multiple types of cells serving a coverage area, varying in frequencies used, radius, and even radio technology used.

HetNets offer significant increases in capacity and improvements, including:

- ❑ Smaller cells, such as open femtocells (home-area coverage) and picocells (city-block-area coverage), inherently increase capacity because each cell serves a smaller number of users.
- ❑ Strategic placement of picocells within the macro cell provides the means to absorb traffic in areas where there are higher concentrations of users. Locations can include businesses, airports, stadiums, convention centers, hotels, hospitals, shopping malls, high-rise residential complexes, and college campuses.
- ❑ Smaller cells can also improve signal quality in areas where the signal from the macro cell is weak.

Essential elements for practical HetNet deployment are self-optimization and self-configuration, especially as the industry transitions from hundreds of thousands of cells to millions. The appendix covers technical aspects of HetNets in the sections, "Heterogeneous Networks and Small Cells" and "Self-Organizing Networks."

While promising in the long term, one immediate challenge in deploying a large number of small cells is backhaul, since access to fiber is not necessarily available and line-of-sight microwave links are not always feasible. Site acquisition and the need for multiple operators to deploy their own cells in a coverage area are additional challenges. Figure 12 depicts some potential difficulties.

**Figure 12: Small-Cell Challenges**

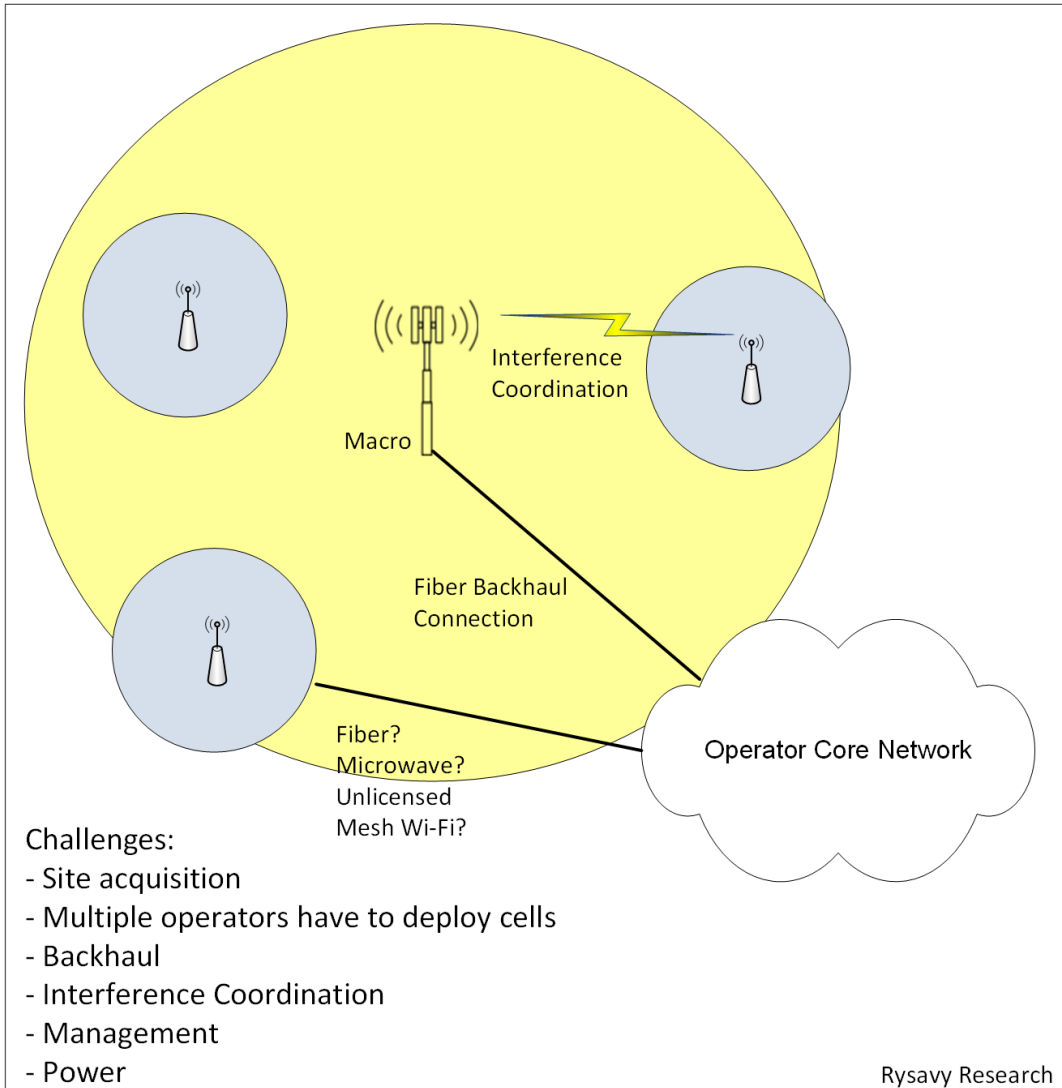

Despite the challenges, small cells will ultimately contribute greatly to increased network capacity. But how will small cells evolve, and what configuration will be most common? That is not yet clear because small-cell architectures are not yet mature. Today's small-cell deployments are still in early stages. Expanding capacity with additional spectrum remains a safer and more immediate solution, explaining why operators are deploying LTE in AWS bands to augment 700 MHz LTE services.

Table 6 lists possible configurations. Note that many of these approaches can be combined, such as using picos and Wi-Fi offload.

**Table 6: Small-Cell Approaches**

Small-Cell Approach	Characteristics
Macro plus small cells in select areas.	Significant standards support. Femtocells or picocells can use same radio carriers as macro (less total spectrum needed) or

Small-Cell Approach	Characteristics
	can use different radio carriers (greater total capacity).
Macro in licensed band plus LTE operation in unlicensed bands.	Being considered for 3GPP Release 13 and available for deployment 2017 or 2018. Promising approach for augmenting LTE capacity in scenarios where operator is deploying LTE small cells. <sup>27</sup>
Macro (or small-cell) cellular in licensed band plus Wi-Fi.	Extensively used today with increased use anticipated. Particularly attractive for expanding capacity in coverage areas where Wi-Fi infrastructure exists but small cells with LTE do not.  LTE Wi-Fi Aggregation (being specified in Release 13) is another approach, as is Multipath TCP.
Wi-Fi only.	Low-cost approach for high-capacity mobile broadband coverage, but impossible to provide large-area continuous coverage without cellular component.

Despite the challenges in rolling out small cells in large numbers, eventually, millions of cells will augment capacity. Contributing factors will include radio-technology advances such as interference coordination, self-organization, equipment miniaturization, improved backhaul options, use of unlicensed spectrum, and additional spectrum such as at 3.5 GHz. Figure 13 shows a global forecast through 2019.

---

<sup>27</sup> See Rysavy Research, "Will LTE in Unlicensed Spectrum Unlock a Vast Store of Mobile Broadband Capacity?" MIMO World, June 2014. Available at <http://www.mimoworld.com/?p=2377>.

**Figure 13: Global Small Cell Forecast<sup>28</sup>**

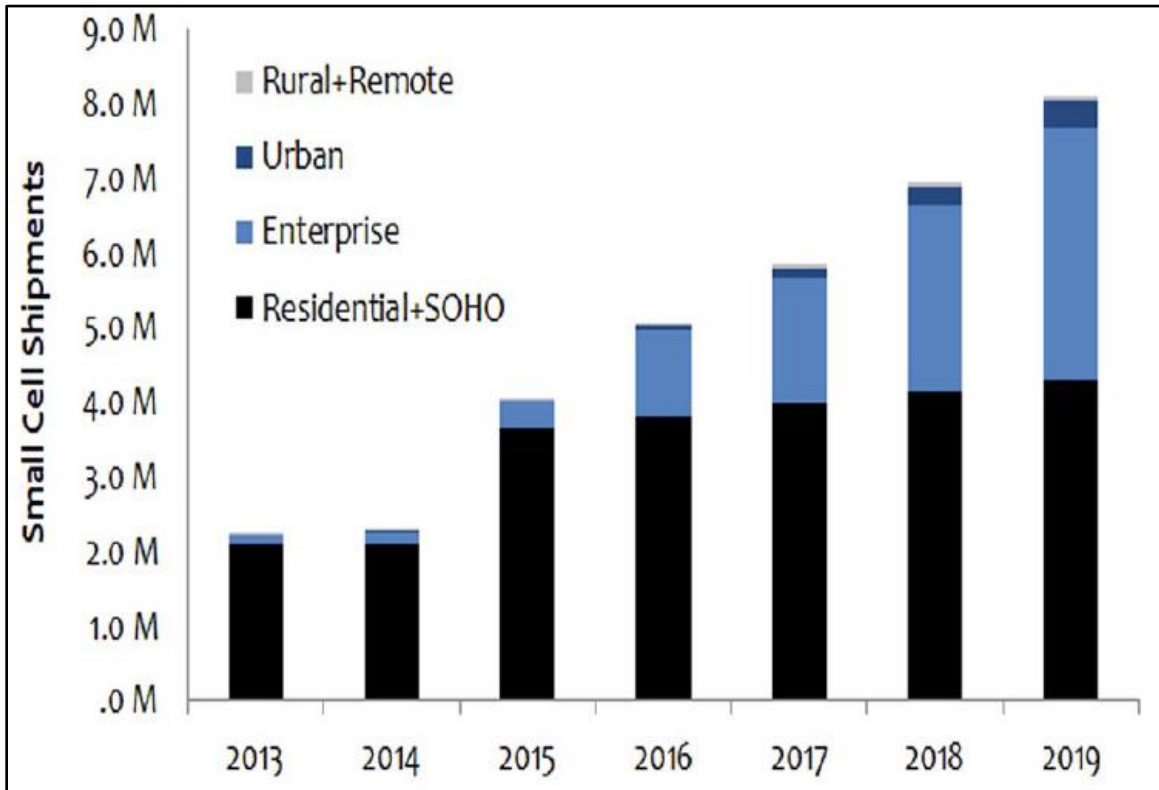

ACG Research reports that the worldwide small-cell market grew by 17.5% over the past year and predicts it will grow five-fold by 2019.<sup>29</sup>

### ***Internet of Things and Machine-to-Machine***

Machine-to-machine communications, increasingly referred to as the Internet of Things, is a vast opportunity for wireless communications, with all 3GPP technologies potentially playing roles.

The lowest-cost devices enabling M2M communications today are GPRS modems, which may become obsolete as operators sunset their GSM systems. HSPA is also used for M2M communications, as is LTE, which has been optimized to efficiently communicate small bursts of information, making it particularly well suited for M2M.

Low-cost LTE modem options in 3GPP releases 10 through 13 reduce cost, improve communications range, and extend battery life. See the appendix section "Internet of Things and Machine-to-Machine" for details.

---

<sup>28</sup> Mobile Experts on behalf of the Small Cell Forum, *Small Cells Deployment Market Status Report*, June 2015.

<sup>29</sup> ACG Research Blog, "Worldwide Small Cell Market to Grow Five-fold by 2019," June 8, 2015. Available at <http://acgresearch.blogspot.com/2015/06/worldwide-small-cell-market-to-grow.html>. Viewed June 10, 2015.

Developers will use 3GPP wireless technologies for a large number of IoT applications. In other instances, developers will use local-area technologies, such as Wi-Fi, Bluetooth Low Energy, and ZigBee. New wide-area wireless technologies emerging specifically to support IoT include LoRa, Sigfox, OnRamp Wireless, and Weightless. The low-power operation of some of these technologies, including LTE, will permit battery operation over multiple years. Table 7 summarizes the various technologies.

**Table 7: Wireless Networks for IoT**

Technology	Coverage	Characteristics	Standardization/ Specifications
GSM/GPRS	Wide area. Huge global coverage.	Lowest-cost cellular modems, risk of network sunsets. Low throughput.	3GPP
HSPA	Wide area. Huge global coverage.	Low-cost cellular modems. Higher power, high throughput.	3GPP
LTE	Wide area. Increasing global coverage.	Wide area, expanding coverage, cost/power reductions in successive 3GPP releases. Low to high throughput options.	3GPP
Wi-Fi	Local area.	High throughput, higher power.	IEEE
ZigBee	Local area.	Low throughput, low power.	IEEE
Bluetooth Low Energy	Personal area.	Low throughput, low power.	Bluetooth Special Interest Group
LoRa	Wide area. Emerging deployments.	Low throughput, low power. Unlicensed bands (sub 1 GHz, such as 900 MHz in the U.S.)	LoRa Alliance
Sigfox	Wide area. Emerging deployments.	Low throughput, low power. Unlicensed bands (sub 1 GHz such as 900 MHz in the U.S.)	Sigfox
OnRamp Wireless	Wide area. Emerging deployments.	Low throughput, low power. Using 2.4 GHz ISM band.	OnRamp Wireless (founding member of IEEE 802.15.4k)
Weightless	Wide area. Expected deployments.	Low throughput, low power. Unlicensed bands (sub 1 GHz such as TV White Space and 900 MHz in the U.S.)	Weightless Special Interest Group

Cloud-based support platforms and standardized interfaces will also facilitate development and deployment of IoT applications. For example, the GSM Association

(GSMA) is developing the OneM2M Service Layer that can be embedded in hardware and software to simplify communications with application servers.<sup>30</sup>

## ***Unlicensed Spectrum Integration***

Unlicensed spectrum is becoming ever more important to mobile broadband networks. Initial use was rudimentary offload onto Wi-Fi networks, but now, Wi-Fi networks are becoming more tightly integrated into cellular networks. Efforts are also underway to use LTE in unlicensed spectrum.

Unlicensed spectrum adds to capacity in two ways. First, a large amount of spectrum (approximately 500 MHz) is available across the 2.4 GHz and 5 GHz bands, with the 3.5 GHz band adding further spectrum in the future. Second, unlicensed spectrum is mostly used in small coverage areas, resulting in high-frequency reuse and much higher throughput rates per square meter of coverage versus typical cellular deployments.

The IEEE 802.11 family of technologies has experienced rapid growth, mainly in private deployments. The latest 802.11 standard, 802.11ac, offers peak theoretical throughputs in excess of 1 Gbps and improved range through use of higher-order MIMO. Recently introduced 802.11ac Wave 2 products include a multi-user MIMO capability that further increases capacity and throughput.

Complementary 802.11 standards increase the attraction of the technology: 802.11e for QoS enables VoIP and multimedia; 802.11i provides robust security; 802.11r delivers fast roaming, necessary for voice handover across access points; and 802.11u enables better hotspot operation.

Leveraging this success, operators—including cellular operators—are offering hotspot service in public areas including airports, fast-food restaurants, shopping malls, and hotels.

Integration between mobile broadband and Wi-Fi networks can be either loose or tight. Loose integration means data traffic routes directly to the Internet and minimizes traversal of the operator network. This is called “local breakout.” Tight integration means data traffic, or select portions, may traverse the operator core network. Wi-Fi calling using IMS, for example, relies on tight integration.

Although offloading onto Wi-Fi can reduce traffic on the core network, the Wi-Fi network does not necessarily always have greater spare capacity than the cellular network. The goal of future integrated cellular/Wi-Fi networks is to intelligently load balance between the two. Simultaneous cellular/Wi-Fi connections will also become possible. For example, in Release 13, 3GPP is introducing link aggregation of Wi-Fi and LTE.

Successfully offloading data and providing users a good experience mandates measures such as automatically provisioning subscriber devices with the necessary Wi-Fi configuration options and automatically authenticating subscribers on supported public Wi-Fi networks. Many stakeholders are working toward tighter integration between Wi-Fi and cellular networks. See the section “Unlicensed Spectrum Integration” in the appendix for technical details on 3GPP and other industry standards and initiatives.

---

<sup>30</sup> OneM2M home page: <http://onem2m.org/>.

One industry initiative gaining momentum is Hotspot 2.0, also called Next Generation Hotspot. Using the IEEE 802.11u standard that allows devices to determine what services are available from an access point, Hotspot 2.0 simplifies the process by which users connect to hotspots, automatically identifying roaming partnerships and simplifying authentication and connections, as shown in Figure 14.<sup>31</sup> It also provides for encrypted communications over the radio link.<sup>32</sup> Devices and networks based on Release 1 of Hotspot 2.0 are available.

**Figure 14: Roaming Using Hotspot 2.0**

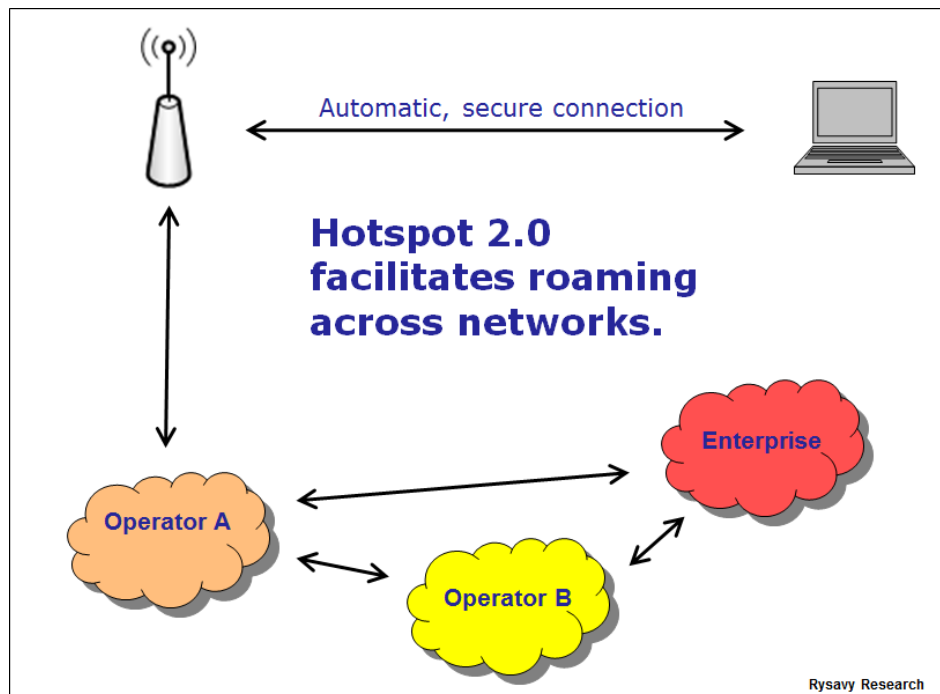

Another approach for using unlicensed spectrum employs LTE as the radio technology, initially in a version referred to as LTE-Unlicensed (LTE-U), which will work with Releases 10-12 of LTE. In Release 13, 3GPP is specifying License-Assisted Access (LAA), which implements listen-before-talk capability, a requirement for unlicensed operation in Europe and Japan. Initially, carrier aggregation combines a licensed carrier with an unlicensed 20 MHz carrier in the 5 GHz band as a supplemental channel. Operating LTE in unlicensed bands could decrease the need for handoffs to Wi-Fi. LTE uses spectrum efficiently under heavy load thanks to its more centralized over-the-air scheduling algorithms.

A concern with using LTE in unlicensed bands is whether it will be a fair neighbor to Wi-Fi users. Release 10-12 LTE-U addresses this concern by methods such as selecting clear channels to use and measuring the channel activity of Wi-Fi users, then using a duty

<sup>31</sup> For example, user devices can be authenticated based on their SIM credentials. Or, users can register or click through an agreement and then not need to redo that with future associations.

<sup>32</sup> The IEEE 802.11i standard has provided encryption for 802.11 communications for many years; however, most hotspots have not implemented this encryption, whereas Hotspot 2.0 does.



cycle low enough to allow Wi-Fi users to access the channel during “off” periods. License-Assisted Access in Release 13 is expected to add listen-before-talk (LBT) and also implement other regulatory requirements that exist in some countries. 3GPP conducted a study and concluded that, “A majority of sources providing evaluation results showed at least one LBT scheme for LAA that does not impact Wi-Fi more than another Wi-Fi network.”<sup>33</sup>

An alternative approach for integrating Wi-Fi is called LTE Wi-Fi Aggregation (LWA). LTE handles the control plane, but connections occur over separate LTE base stations and Wi-Fi access points. Devices need only a software upgrade.

Table 8 summarizes the different uses of unlicensed spectrum for public mobile-broadband networks.

**Table 8: Approaches for Using Unlicensed Spectrum.**

	Technology	Attributes
<b>Wi-Fi</b>	Ever-more-sophisticated means to integrate Wi-Fi in successive 3GPP Releases.	Significantly enhances capacity.
<b>Release 10-12 LTE-U</b>	Approach for operating LTE in unlicensed spectrum.	Available in 2016. More seamless than Wi-Fi. Cannot be used in some regions (e.g., Europe, Japan).
<b>Release 13 Licensed-Assisted Access</b>	Standards-based approach for operating LTE in unlicensed spectrum.	Available in 2018 timeframe. Designed to be good Wi-Fi neighbor and to address global regulatory requirements.
<b>LTE Wi-Fi Aggregation (LWA)</b>	Aggregation of LTE and Wi-Fi connections	Part of Release 13. Available in 2018 timeframe.

Refer to the appendix section “Unlicensed Spectrum Integration” for further technical details.

## **Smart Antennas and MIMO**

Smart antennas, defined with progressively greater capabilities in successive 3GPP releases, provide significant gains in throughput and capacity. By employing multiple antennas at the base station and the subscriber unit, the technology either exploits signals traveling through multiple paths in the environment or does beam-steering, in which multiple antennas coordinate their transmissions to focus radio energy in a particular direction.

---

<sup>33</sup> 3GPP, *Technical Specification Group Radio Access Network; Study on Licensed-Assisted Access to Unlicensed Spectrum; (Release 13)*. 36.889. See section 9, “Conclusions.”

Initial low-band LTE deployments used 2X2 MIMO on the downlink (two base station transmit antennas, two mobile receive antennas) and 1X2 on the uplink (one mobile transmit antenna, two base station receive antennas). In the higher bands, 2X2 downlink MIMO has been deployed, but it is more common to employ four antennas for uplink reception in a 1X4 configuration. Some LTE deployments are now using 4X2 MIMO on the downlink (four base station transmit antennas). LTE specifications encompass higher-order configurations, such as 4X4 MIMO, 8X2 MIMO, and MU-MIMO on the downlink and 1X4 on the uplink. Practical considerations, such as antenna sizes that are proportional to wavelength, dictate MIMO options for different bands.

Engineers are now experimenting with what are called massive MIMO systems, which employ a far larger number of antenna elements at the base station—64, 128, and eventually even more. Use in 5G of cmWave and mmWave bands, with their short wavelengths, will facilitate massive MIMO, but even before then, 3GPP is studying massive MIMO for 4G systems in what it calls full-dimension MIMO (FD-MIMO). Two-dimensional antenna arrays may use up to 64 antennas. At 2.5 GHz, an 8X8 array using half wavelength spacing would produce a form factor of 50 cm X 50 cm. Applications of such arrays include beamforming along a horizontal direction as well as beamforming in a vertical direction, such as to serve different levels of high-rise buildings.

See the appendix section “LTE Smart Antennas” for further details.

## **Virtualization**

Virtualization refers to implementing the functions of infrastructure nodes in software on commercial “off-the-shelf” computing equipment. The approach promises lower capital expenditures, lower operating costs, faster deployment of new services, energy savings, and improved network efficiency. With NFV, multiple tenants will be able to share the same infrastructure, facilitating, for example, mobile virtual network operator (MVNO) arrangements. NFV, however, also constitutes an entirely new way of building and managing networks, so widespread adoption will occur over a long period.<sup>34</sup>

Both the core network and the radio-access network can be virtualized. The core network, consisting of fewer nodes, is an easier starting point. Virtualizing the RAN, although more complex, could eventually provide the greatest network efficiency gains, particularly for small-cell deployments where it can facilitate coordination among cells and use of methods such as CoMP and interference coordination. As operators virtualize their core networks, they put in place the systems and know-how to extend virtualization to the RAN.

The European Telecommunications Standards Institute (ETSI) is standardizing a framework, including interfaces and reference architectures for virtualization. Other standards and industry groups involved include 3GPP, The Open Network Foundation, OpenStack, Open Daylight, and OPNFV. 3GPP specifications do not currently incorporate NFV.<sup>35</sup>

---

<sup>34</sup> For an example of an NFV deployment, see AT&T, *AT&T Domain 2.0 Vision White Paper*, November 2013.

<sup>35</sup> 3GPP, “Network Functions Virtualisation,” <http://www.3gpp.org/technologies/keywords-acronyms/1584-nfv>, accessed June 24, 2015.

Figure 15 shows the ETSI framework, in which virtualized network functions are the nodes or applications by which operators build services.

**Figure 15: ETSI NFV High-Level Framework**

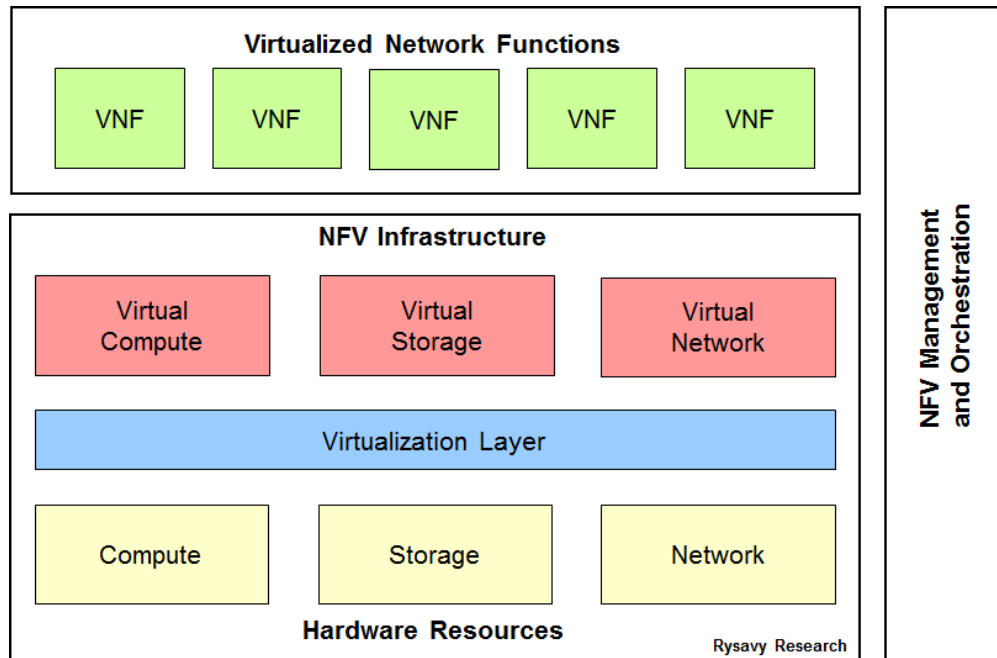

Some specific use cases for NFV include:

- ❑ **IMS and VoLTE.** IMS is necessary for VoLTE, but an NFV approach could reduce the complexity associated with the multiple nodes and interfaces in the IMS architecture.
- ❑ **Virtualized EPC (VEPC).** The Evolved Packet Core, consisting of the Serving Gateway (SGW), the Packet Gateway (PGW), and Mobile Management Entity (MME), can be virtualized, but doing so will require meeting operator bandwidth, latency, and control-plane service requirements.
- ❑ **New VEPC Services.** With a virtualized EPC, an operator can more easily create MVNO services, each with its own virtualized MME, SGW, and PGW. An M2M virtualized service is another example of offering a more finely tuned service for the target application. Because the PGW connects to external networks, further opportunities exist for virtualized services to augment networking functions, including video caching, video optimization, parental controls, ad insertion, and firewalls.
- ❑ **Cloud RAN.** Pooling of baseband processing in a cloud RAN can, but does not necessarily, use virtualization techniques. Separating the radio function from baseband processing typically requires transporting digitized radio signals across high-bandwidth (multi-Gbps) fiber connections, sometimes referred to as front-

hauling. Refer to the appendix section "Cloud Radio-Access Network (RAN) and Network Virtualization" for a more detailed technical discussion.<sup>36</sup>

All of these use cases will take years to mature given the complexity of the systems and their stringent performance requirements. Because of higher investment demands, RAN virtualization will probably emerge over a longer timeframe than core network virtualization, and likely will occur selectively for small-cell deployments.

For additional details, refer to the 4G Americas white paper, *Bringing Network Function Virtualization to LTE*.<sup>37</sup>

## **Fixed Mobile Convergence and IMS**

Not only do 3GPP technologies provide continual improvements in capacity and data performance, they also expand available services, either through operator-provided services, such as IP-based voice or video calling, or via interfaces that enable third-party services, such as WebRTC. This section provides an overview of these topics, and the appendix goes into greater detail.

Fixed Mobile Convergence (FMC) refers to the integration of fixed services (such as telephony provided by wireline or Wi-Fi) with mobile cellular-based services. For users, FMC simplifies how these services communicate, making it possible for them to use one device at work, where it connects with a Wi-Fi or macrocellular network, and at home, where it might connect with a Wi-Fi network or femtocell. Users can also benefit from single voice mailboxes and single phone numbers and gain greater control over how and with whom they communicate.

For operators, FMC allows for consolidation of core services across multiple-access networks. For instance, an operator can offer complete VoIP-based services that operate over Digital Subscriber Line (DSL), Wi-Fi, or mobile broadband. FMC can also offload data-intensive applications, such as video streaming, from the macro network.

IMS is the most important convergence technology, offering access to core services and applications across multiple-access networks. IMS allows for creative blending of different types of communications and information, including voice, video, instant messaging (IM), presence information, location, and documents. Developers can create applications never before possible, and users can communicate in entirely new and dynamic ways. For example, during an interactive text-based chat session, a user could launch a voice call. Or during a voice call, a user could suddenly add a simultaneous video connection, or start transferring files. While browsing the Web, a user could decide to speak to a customer-service representative.

IMS will be a key platform for all-IP architectures for both HSPA and LTE. Although IMS adoption by cellular operators was initially slow, deployment is accelerating as operators make packet voice service available for LTE.

---

<sup>36</sup> For further details of NFV use cases, refer to ETSI, *ETSI GS NFV 001 v.1.1.1 (2013-10), Network Functions Virtualisation (NFV); Use Cases*.

<sup>37</sup> Available at [http://www.4gamericas.org/files/1014/1653/1309/4G\\_Americas\\_-\\_NFV\\_to\\_LTE\\_-\\_November\\_2014\\_-\\_FINAL.pdf](http://www.4gamericas.org/files/1014/1653/1309/4G_Americas_-_NFV_to_LTE_-_November_2014_-_FINAL.pdf).

## ***Multicast and Broadcast***

Another important new service is video streaming via multicast or broadcast functions. 3GPP has defined multicast/broadcast capabilities for both HSPA and LTE. Although Mobile TV services have experienced little business success so far, broadcasting uses the radio resource much more efficiently than having separate point-to-point streams for each user. For example, users at a sporting event might enjoy watching replays on their smartphones. The technology supports these applications; it is a matter of operators and content providers finding appealing applications. The appendix covers technical aspects in more detail.

# VoLTE, RCS, WebRTC, and Wi-Fi Calling

Voice is evolving from a separate circuit-switched service in 2G and 3G networks to a packet-switched-service in 4G LTE networks that can integrate with other services and applications, including messaging, video calling, Web applications, and other mobile applications. The elements that make these capabilities possible include the quality-of-service mechanisms in LTE, the IMS platform discussed above, implementation of Rich Communications Suite, compliance with GSMA IR.92 guidelines, and optional support for WebRTC.

## ***Voice Support and VoLTE***

While 2G and 3G technologies were deployed from the beginning with both voice and data capabilities, LTE networks can be deployed with or without voice support. Moreover, there are two methods available: circuit-switched fallback (CSFB) to 2G/3G and VoIP. Most operators deploying LTE are using CSFB initially and migrating to VoIP methods with Voice over LTE (VoLTE) that uses IMS. Initial VoLTE deployments occurred in 2012. Because VoLTE needs new software in phones, the transition from circuit-switched voice to VoLTE on a large scale will occur over a number of years as users upgrade their devices.

For the time being, 3GPP operators with UMTS/HSPA networks will continue to use circuit-switched voice for their 3G connections, although packet voice over HSPA (VoHSPA) methods have been defined.<sup>38</sup>

Using VoLTE, operators are planning high-definition (HD) voice using the new Adaptive Multi-Rate Wideband (AMR-WB) voice codec. HD voice not only improves voice clarity and intelligibility, it also suppresses background noise. AMR-WB extends audio bandwidth to 50-7000 Hz compared with the narrowband codec that provides audio bandwidth of 80-3700 Hz. HD voice will initially function only between callers on the same network. 3GPP is also developing a new voice codec, called Enhanced Voice Services (EVS), which will be the successor to AMR and AMR-WB codecs.

Other advantages of LTE's packetized voice include being able to combine it with other services, such as video calling and presence; half the call setup time of a 3G connection; and high voice spectral efficiency. Some operators, such as in Canada, are deploying only LTE networks, making voice support essential. With VoLTE's HD voice quality, lower delay, and higher capacity, operators can compete against OTT VoIP providers. Due to traffic prioritization, VoLTE voice quality remains high even under heavy loads that cause OTT voice service to deteriorate.

Applications based on WebRTC will also increasingly carry voice sessions. See the section "VoLTE and RCS" in the appendix for more details on LTE voice support.

---

<sup>38</sup> For further details, see 4G Americas, *Delivering Voice Using HSPA*, February 2012.

Available at

[http://www.4gamericas.org/documents/4G%20Americas%20VoHSPA%20paper\\_final%20%2022%2012.pdf](http://www.4gamericas.org/documents/4G%20Americas%20VoHSPA%20paper_final%20%2022%2012.pdf).

## ***Rich Communications Suite***

An initiative called Rich Communications Suite (RCS), supported by many operators and vendors, builds on IMS technology to provide a consistent feature set as well as implementation guidelines, use cases, and reference implementations. RCS uses existing standards and specifications from 3GPP, Open Mobile Alliance (OMA), and GSMA and enables interoperability of supported features across operators that support the suite. RCS supports both circuit-switched and packet-switched voice and can interoperate with LTE packet voice.

Core features include:

- ❑ A user capability exchange or service discovery with which users can know the capabilities of other users.
- ❑ Enhanced (IP-based) messaging (supporting text, IM, and multimedia) with chat and messaging history.
- ❑ Enriched calls that include multimedia content (such as photo or video sharing) during voice calls. This could become the primary way operators offer video calling.

The primary drivers for RCS adoption are the ability to deploy VoLTE in a well-defined manner and to support messaging in the IP domain. RCS addresses the market trend of users moving away from traditional text-based messaging and provides a platform for operator-based services that compete with OTT messaging applications. Figure 16 shows the evolution of RCS capability, including the addition of such features as messaging across multiple devices, video calling, video sharing, and synchronized contact information across multiple devices.

**Figure 16: Evolution of RCS Capability.**<sup>39</sup>

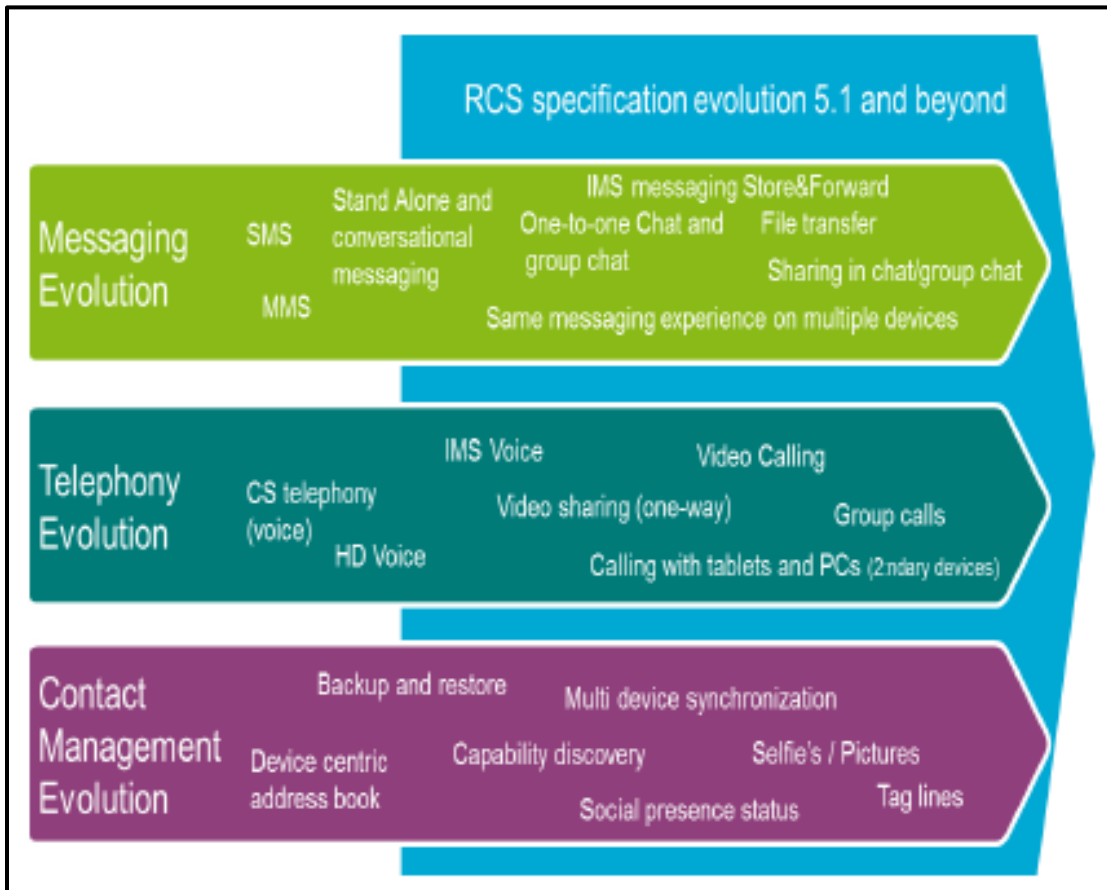

## WebRTC

WebRTC is an open project supported by Google, Mozilla, and Opera within the Internet Engineering Taskforce (IETF) that enables real-time communications in Web browsers via JavaScript APIs. 3GPP Release 12 specifications define how WebRTC clients can access IMS services, including packet voice and video communication. WebRTC operating over IMS gains the additional benefit of seamless transition across transport networks, for example, LTE to Wi-Fi.

Operators can integrate WebRTC with RTC, facilitating development of vertical applications such as telemedicine and customer service. WebRTC and RCS are more complementary than competitive. Both, through application interfaces, can provide access to underlying network functions.

## Wi-Fi Calling

Another advantage of the VoLTE/IMS/RCS architecture is that it is agnostic to the user connection, meaning voice and video service can extend to Wi-Fi connections as easily as

<sup>39</sup> 4G Americas.



LTE connections. Wi-Fi calling can be advantageous in coverage areas where the Wi-Fi signal has better quality than an LTE signal. For video calling, use of Wi-Fi will also reduce data consumption over the cellular connection. By implementing a standards-based approach, as opposed to OTT-voice approaches, called parties see the same phone number regardless of network and can reach the subscriber using that phone number.

Previous technical approaches, such as Generic Access Network (GAN, initially called Unlicensed Mobile Access [UMA]), did not include as robust a handover mechanism as is provided by VoLTE/IMS.

For the best-quality voice in a Wi-Fi network, the device and Wi-Fi network should implement Wi-Fi Multimedia (WMM), which gives voice packets higher priority than other data traffic. WMM is especially necessary in congested networks. In addition, the Access Network Discovery and Selection Function (ANDSF) and cellular-WLAN enhancement features in 3GPP Release 12 introduce policies for enabling voice handover between LTE and Wi-Fi.

Roaming with Wi-Fi calling will need to address whether the visited network's IMS infrastructure handles the Wi-Fi call or whether the home network's IMS does.

# Public Safety

An important LTE application is for public safety, initially as a broadband data service and eventually for mission-critical voice service. Current public safety networks use technologies, such as Terrestrial Trunked Radio (TETRA) in Europe and Project P25 in the United States, that provide mission-critical voice but only narrowband data.

In the United States, the government has made 20 MHz of spectrum available at 700 MHz in band 14 and created the First Responder Network Authority (FirstNet), an independent authority within the National Telecommunications and Information Administration (NTIA) to provide a nationwide public-safety broadband network. Another country driving the use of LTE for public safety is the United Kingdom, where the UK Home Office has a program for the Emergency Service Network.

Using LTE for public safety is a complex undertaking because public-safety needs differ from those of consumers. Addressing these needs requires both different features, which 3GPP is incorporating in multiple releases of LTE specifications, and different network deployment approaches. Public safety also has different device-level needs than consumers.

## ***LTE Features for Public Safety***

Some broadband applications for public safety can use standard LTE capability. For example, sending email, accessing a database, or streaming a video may not require any special features. Other applications, however, require new capabilities from 3GPP standards, including:

### **Group Communication**

Available in Release 12, the Group Communication Service (GCS) application server, using one-to-one (unicast) and one-to-many communications (broadcast), will be able to send voice, video, or data traffic to multiple public-safety devices. The broadcast mode will use eMBMS to use radio resources efficiently, but if coverage is weak, a unicast approach may deliver data more reliably. The system will be able to dynamically switch between broadcast and unicast modes.

A Release 13 study item is investigating single-cell point-to-multipoint transmission that would use radio resources more efficiently than with eMBMS.

### **Proximity-Based Services (Device-to-Device)**

With proximity-based services, defined in Release 12, user devices will be able to communicate directly, a capability that will benefit both consumers and public safety. Consumer devices can find other devices only with assistance from the network, but for public safety, devices will be able to communicate directly with other devices independently of the network.

In Release 13, devices will be able to act as relays for out-of-coverage devices, such as inside a building.

The appendix section "Proximity Services (Device-to-Device)" discusses this feature in greater detail.

## Mission-Critical Push-to-Talk

MCPTT, being defined in Release 13, will provide one-to-one and one-to-many push-to-talk communications services. With this feature, available in the 2018 timeframe, public-safety organizations will be able to consider retiring legacy voice-based systems.

## Prioritization

To prevent interference with public-safety operations in emergency situations experiencing high load, the network can prioritize at multiple levels. First, the network can bar consumer devices from attempting to access the network, thus reducing signaling load. Second, the network can prioritize radio resources, giving public-safety users higher priority. Third, using a new capability called Multimedia Priority Service (MPS), the network can prioritize a connection between an emergency worker and a regular subscriber. Finally, the network can assign specific quality-of-service (QoS) parameters to specific traffic flows, including guaranteed bit rate. 3GPP has defined specific QoS quality-class identifiers for public safety.

## High power

Release 11 defines higher-power devices for the public safety band that can operate at 1.25 Watts, improving coverage and reducing network deployment costs.

## Isolated operation

In Release 13, 3GPP is expected to specify how a base station can continue offering service even with the loss of backhaul, a capability that will benefit disaster situations.

## Relays

Figure 17 summarizes the more than eighteen features in 3GPP relays that apply to public safety.

**Figure 17: Summary of 3GPP LTE Features to Support Public Safety<sup>40</sup>**

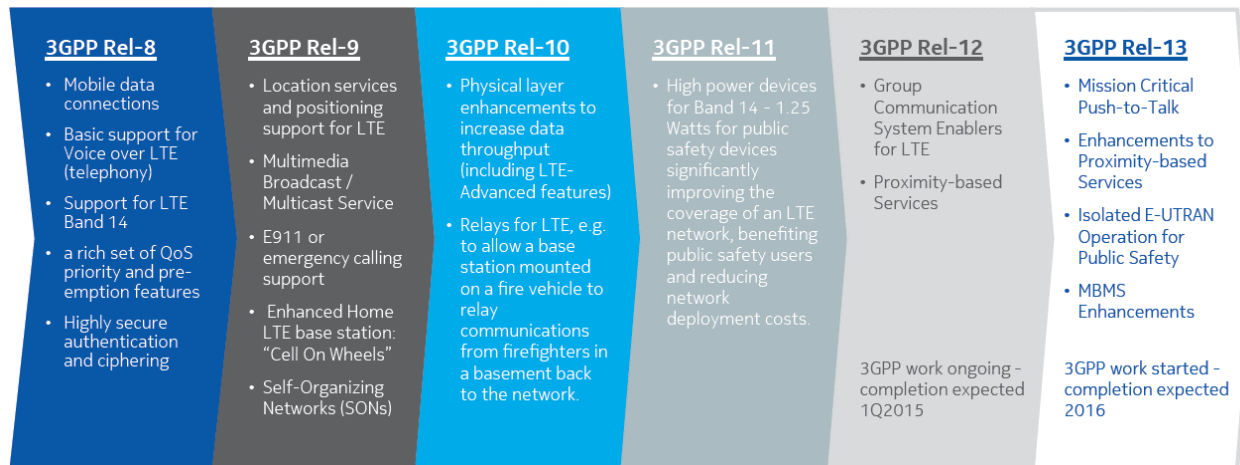

<sup>40</sup> Nokia, *LTE networks for public safety services*, 2014. Available at [http://networks.nokia.com/sites/default/files/document/nokia\\_lte\\_for\\_public\\_safety\\_white\\_paper.pdf](http://networks.nokia.com/sites/default/files/document/nokia_lte_for_public_safety_white_paper.pdf).

## ***Deployment Schedule and Approaches***

In the United States, FirstNet is expected to issue an official RFP in late 2015, followed by the possibility of an award in 2016. Deployments could begin in the 2017-2018 timeframe.

Because huge investment in infrastructure would be required for a network dedicated only to public safety, industry and government are evaluating approaches with which public safety can leverage existing commercial network deployments. Public-safety networks also have resilience and security requirements that differ from commercial networks.

### **Shared Network**

As depicted in Figure 18, multiple sharing approaches are possible:

1. In this scenario, public safety owns and operates the entire network, an approach that gives public-safety organizations the greatest control over the network but at the highest cost.
2. A commercial operator shares its radio-access network, including cell sites and backhaul, but the public-safety entity manages core network functions including gateways, the Mobile Management Entity, the Home Subscriber Server (HSS), and public-safety application servers. Because the radio-access network is the most costly part of the network, this approach significantly reduces the amount public safety has to invest in the network. Even though the RAN is shared, public safety still can use its dedicated spectrum.
3. In an MVNO approach, the operator shares its cell sites and backhaul as well as some core network functions, such as the MME and Serving Gateway. Public safety manages a small number of network functions, such as the Packet Gateway, HSS, and its application servers.
4. A final approach, not shown in the figure, is one in which the mobile operator hosts all of the elements shown in the figure and public safety manages only its application servers.

**Figure 18: Sharing Approaches for Public Safety Networks**

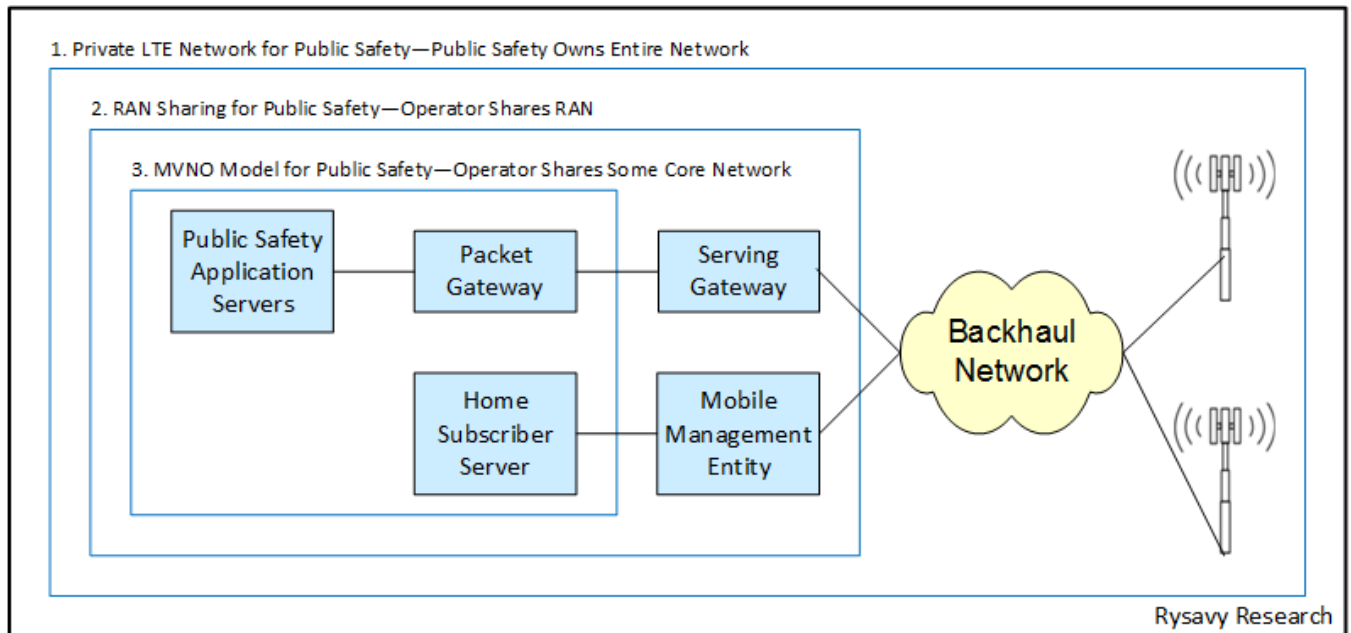

## Resilience

Public safety may need greater resilience than found in commercial networks, including hardware redundancy, geographic redundancy, load balancing, fast re-routing in IP networks, interface protection, outage detection, self-healing, and automatic reconfiguration.

## Security

Public-safety networks may have higher security requirements than commercial networks, including physical security of data centers, core sites, and cell sites. Whereas LTE networks do not have to encrypt traffic in backhaul and core networks, public-safety applications may choose to encrypt all IP traffic using virtual private networking approaches.

## Coverage

A number of approaches can ensure the broadest possible coverage for public-safety networks. First, public-safety frequencies at 700 MHz already propagate and penetrate well. Next, public-safety devices will be able to transmit at higher power. In addition, base stations can employ four-way receiver diversity and higher-order sectorization. For disaster situations, public safety can also use rapidly deployable small cells, such as on trailers. Finally, proximity-based services operating in a relay mode, as discussed above, can extend coverage.

## ***Device Considerations for Public Safety***

Public-safety devices will have unique requirements, including guaranteed network access under all conditions and guidelines for how devices are shared among users.

## Access to Commercial Networks

Public-safety devices could be designed to also to communicate on commercial LTE networks, providing an alternate communications avenue when the device cannot connect to a public-safety network. Subscriptions to all major commercial networks would make this approach the most effective. Wi-Fi capability further extends this concept.

### **Device Sharing**

Because public-safety devices may be shared among personnel, user profiles cannot be stored on USIM cards stored in the devices. Bluetooth-based remote SIMs are one approach to address this problem.

## Expanding Capacity

Wireless technology is playing a profound role in networking and communications, even though wireline technologies such as fiber have inherent capacity advantages.

Wireless networks can provide a largely equivalent broadband experience for many applications, but for ones that are extremely data intensive, wireline connections will remain a better choice for the foreseeable future. For example, users streaming Netflix movies in high definition consume about 5 Mbps. Typical LTE deployments use 10 MHz radio channels on the downlink and have a spectral efficiency of 1.4 bps/Hertz (Hz), providing LTE an average sector capacity of 14 Mbps. Thus, just three Netflix viewers could exceed sector capacity. In the United States, each cell site has approximately 1,100 subscribers, on average<sup>41</sup>, hence about 360 for each of the three sectors commonly deployed in a cell site. In dense urban deployments, the number of subscribers can be significantly higher. Therefore, just a small percentage of subscribers can overwhelm network capacity. For Blu-ray video quality that operates at around 16 Mbps or Netflix 4K streaming that runs at 15.6 Mbps, an LTE cell sector could support only one user.

Even if mobile users are not streaming full-length movies in high definition, video is finding its way into many applications, including education, social networking, video conferencing, business collaboration, field service, and telemedicine.

Over time, wireless networks will gain substantial additional capacity through the methods discussed in the next section, but they will never catch up to wireline. One can understand this from a relatively simplistic physics analysis:

- ❑ Wireline access to the premises or to nearby nodes uses fiber-optic cable.
- ❑ Capacity is based on available bandwidth of electromagnetic radiation. The infra-red frequencies used in fiber-optic communications have far greater bandwidth than radio.
- ❑ The result is that just one fiber-optic strand has greater bandwidth than the entire usable radio spectrum to 100 GHz, as illustrated in Figure 19.<sup>42</sup>

---

<sup>41</sup> Year-end 2013, the U.S. had 335.65M subscribers and 304,360 cell sites, resulting in an average of 1,103 subscribers per cell. CTIA, "Annual Wireless Summary Report, Year-End 2013," 2014, <http://www.ctia.org/your-wireless-life/how-wireless-works/annual-wireless-industry-survey>, accessed July 17, 2014.

<sup>42</sup> One fiber-optic cable can transmit over 10,000 Gbps compared with all wireless spectrum to 100 GHz that, even at an extremely high 10 bps/Hz, would have only 1,000 Gbps of capacity.

**Figure 19: RF Capacity vs. Fiber-Optic Cable Capacity**

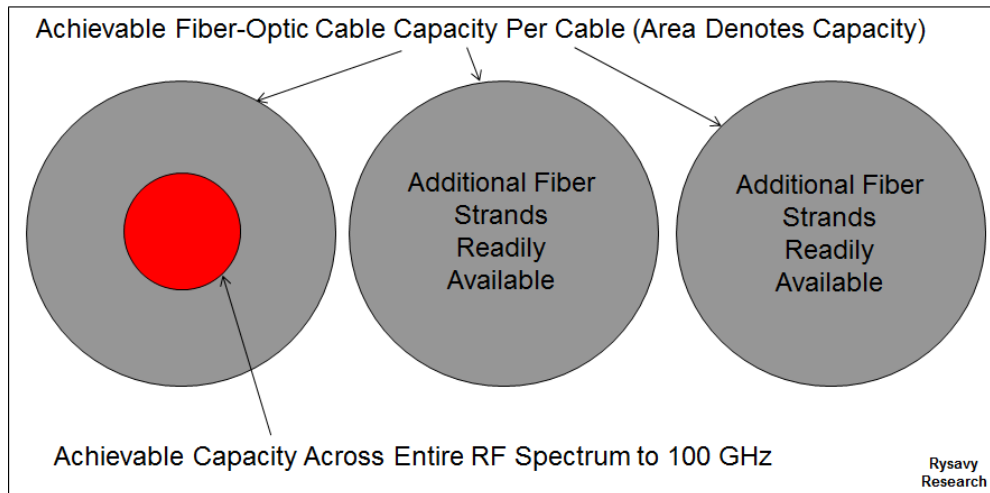

A dilemma of mobile broadband is that it *can* provide a broadband experience similar to wireline, but it *cannot* do so for all subscribers in a coverage area at the same time. Hence, operators must carefully manage capacity, demand, policies, pricing plans, and user expectations. Similarly, application developers must become more conscious of the inherent constraints of wireless networks.

Mobile broadband networks are best thought of as providing access to higher-capacity wireline networks. The key to improving per-subscriber performance and bandwidth is reducing the size of cells and minimizing the radio path to the wireline network, thus improving signal quality and decreasing the number of active devices in each cell. These are the motivations for Wi-Fi offload and small-cell architectures.

With operators in some countries or markets shifting pricing for data usage from unlimited to tiered, users have become more conscious of how much data they consume. Application (app) developers have also provided tools for managing bandwidth by, for instance, allowing users to specify the maximum size of emails to automatically download. Nevertheless, average usage keeps growing.

Three factors determine wireless network capacity, as shown in Figure 20: the amount of spectrum, the spectral efficiency of the technology, and the size of the cell. Because smaller cells serve fewer people in each cell and because there are more of them, small cells are a major contributor to increased capacity.



**Figure 20: Dimensions of Capacity**

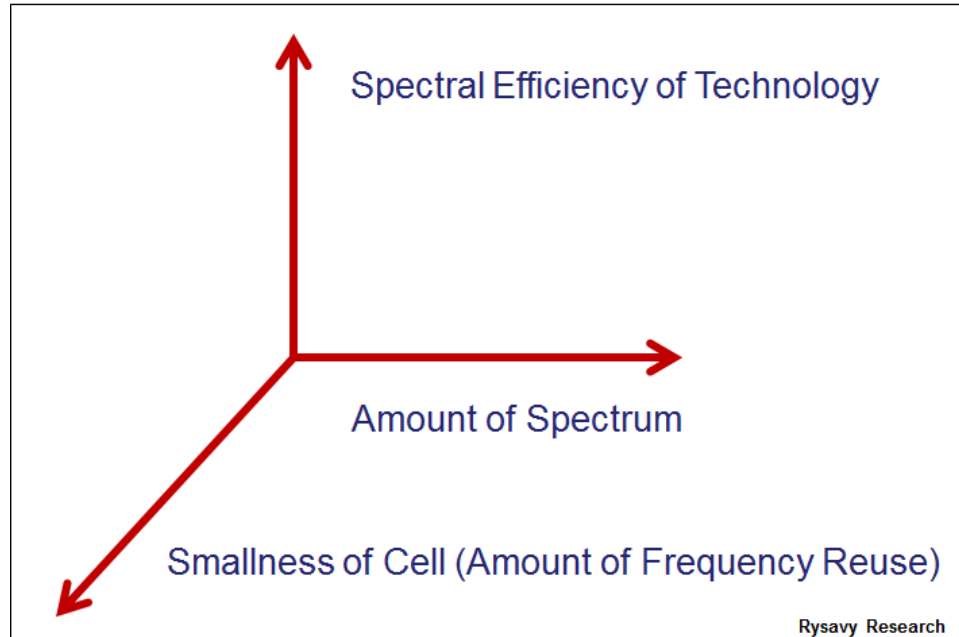

Given the relentless growth in usage, mobile operators are combining multiple approaches to increase capacity and managing congestion:

- ❑ **More spectrum.** Spectrum correlates directly to capacity, and more spectrum is becoming available globally for mobile broadband. In the U.S. market, the FCC National Broadband Plan seeks to make an additional 500 MHz of spectrum available by 2020. Multiple papers by Rysavy Research and others<sup>43</sup> argue the critical need for additional spectrum.
- ❑ **Unpaired spectrum.** LTE TDD operates in unpaired spectrum. In addition, technologies such as HSPA+ and LTE permit the use of different amounts of spectrum between downlink and uplink. Additional unpaired downlink spectrum can be combined with paired spectrum to increase capacity and user throughputs.
- ❑ **Supplemental downlink.** With downlink traffic five to ten times greater than uplink traffic, operators often need to expand downlink capacity rather than uplink capacity. Using carrier aggregation, operators can augment downlink capacity by combining separate radio channels.
- ❑ **Spectrum sharing.** Policy makers are evaluating how spectrum might be shared between government and commercial entities. Although a potentially promising approach for the long term, sharing raises complex issues, as discussed further in the section "Spectrum Developments."
- ❑ **Increased spectral efficiency.** Newer technologies are spectrally more efficient, meaning greater aggregate throughput using the same amount of spectrum. Wireless technologies such as LTE, however, are reaching the theoretical limits of spectral

---

<sup>43</sup> See multiple papers on spectrum and capacity at <http://www.rysavv.com/writing>.

efficiency, and future gains will be quite modest, allowing for a possible doubling of LTE efficiency over currently deployed versions. See the section “Spectral Efficiency” for a further discussion.

- ❑ **Smart antennas.** Through higher-order MIMO and beamforming, smart antennas gain added sophistication in each 3GPP release and are the primary contributor to increased spectral efficiency (bps/Hz).
- ❑ **Uplink gains combined with downlink carrier aggregation.** Operators can increase network capacity by applying new receive technologies at the base station (for example, large-scale antenna systems such as massive MIMO) that do not necessarily require standards support. Combined with carrier aggregation on the downlink, these receive technologies produce a high-capacity balanced network, suggesting that regulators should in some cases consider licensing just downlink spectrum.
- ❑ **Small cells and heterogeneous networks.** Selective addition of picocells to macrocells to address localized demand can significantly boost overall capacity, with a linear increase in capacity relative to the number of small cells. HetNets, which also can include femtocells, hold the promise of increasing capacity gains by a factor of four and even higher with the introduction of interference cancellation in devices. Distributed antenna systems (DAS), used principally for improved indoor coverage, can also function like small cells and increase capacity. Actual gain will depend on a number of factors, including number and placement of small cells<sup>44</sup>, user distribution, and any small-cell selection bias that might be applied.
- ❑ **Offload to unlicensed spectrum.** Using unlicensed spectrum with Wi-Fi or LTE operation in unlicensed spectrum offers another means of offloading heavy traffic. Unlicensed spectrum favors smaller coverage areas because interference can be better managed, so spectral re-use is high, resulting in significant capacity gains.
- ❑ **Higher-level sectorization.** For some base stations, despite the more complex configuration involved, six sectors can prove advantageous versus the more traditional three sectors, deployed either in a 6X1 horizontal plane or 3X2 vertical plane<sup>45</sup>.

Strategies to manage demand include:

- ❑ **Quality of service (QoS) management.** Through prioritization, certain traffic, such as non-time-critical downloads, could occur with lower priority, thus not affecting other active users. New network-neutrality rules, however, may constrain use of traffic prioritization.<sup>46</sup>
- ❑ **Off-peak hours.** Operators could offer user incentives or perhaps fewer restrictions on large data transfers during off-peak hours.

---

<sup>44</sup> With small-cell range expansion using a large selection bias, small cells can be distributed uniformly.

<sup>45</sup> An example of vertical layering would be a 3X1 layer at ground level and a separate 3X1 layer for higher levels of surrounding buildings.

<sup>46</sup> For a discussion of this issue, see Rysavy Research, *LTE Congestion Management – Enabling Innovation and Improving the Consumer Experience*, January 2015. Available at <http://www.rysavy.com/Articles/2015-01-Rysavy-LTE-Congestion-Management.pdf>.

Figure 21 demonstrates the gains from using additional spectrum and offload. The bottom (green) curve is downlink throughput for LTE deployed in 20 MHz, with 10 MHz on the downlink and 10 MHz on the uplink, relative to the number of simultaneous users accessing the network. The middle (purple) curve shows how using an additional 20 MHz doubles the throughput for each user, and the top (orange) curve shows a further possible doubling through aggressive data offloading onto unlicensed spectrum.

**Figure 21: Benefits of Additional Spectrum and Offload**

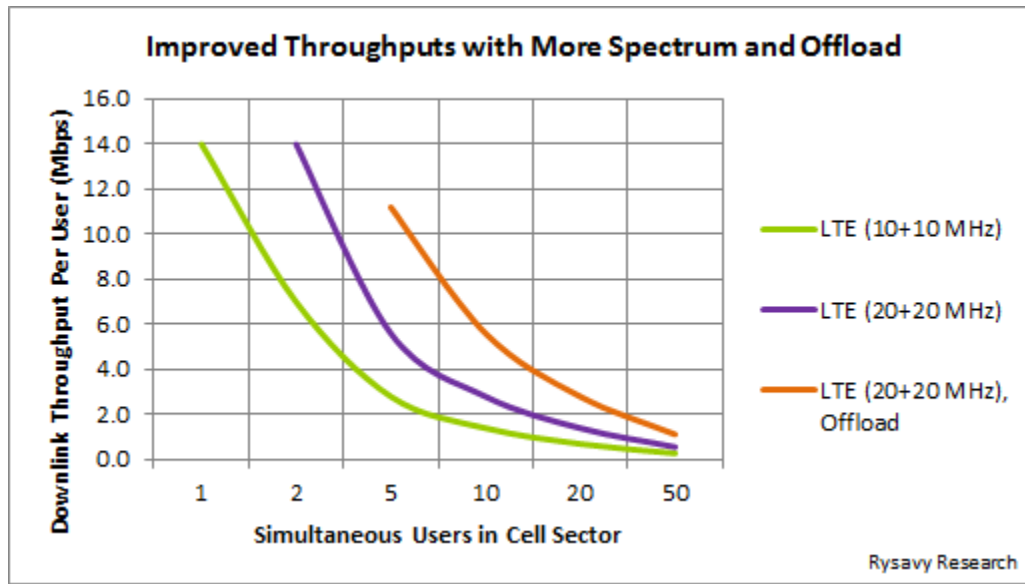

Given a goal of increasing capacity by a factor of 1,000, 50X could roughly be achieved through network densification; 10X through more spectrum, including higher frequencies such as mmWave; and 2X by increases in spectral efficiency.

Based on historical increases in the availability of new spectrum, technologies delivering better spectral efficiency, and increases in the number of cell sites, Rysavy Research has calculated that, over the last thirty-year period, aggregate network capacity has doubled every three years. Rysavy Research expects this trend to continue into the future.

**Rysavy Research Analysis:**  
**Aggregate Wireless Network Capacity**  
**Doubles Every Three Years.**

## Spectrum Developments

Spectrum scarcity continues to challenge the industry. Tactics to make the best use of this limited resource include deploying technologies that have higher spectral efficiency; adapting specifications to enable operation of UMTS-HSPA and LTE in all available bands; designing both FDD and TDD versions of technology to take advantage of both paired and unpaired bands; designing carrier aggregation techniques in HSPA+ and LTE-Advanced; and deploying as many new cells, large and small, as is economically and technically feasible.

Although all of these industry initiatives greatly expand capacity, they do not obviate the need for additional spectrum.

The FCC released a report in October 2010 that projected U.S. spectrum requirements<sup>47</sup> and concluded that 275 MHz of additional spectrum would be needed within five years and 500 MHz of additional spectrum within 10 years. This forecast assumes ongoing increases in spectral efficiency from improving technologies.

An important aspect of UMTS-HSPA and LTE deployment is for infrastructure and mobile devices to accommodate the expanding number of available radio bands. The fundamental system design and networking protocols remain the same for each band; only the frequency-dependent portions of the radios must change. As other frequency bands become available for deployment, standards bodies adapt UMTS-HSPA and LTE for these bands as well.

3GPP has specified LTE for operation in many different bands, and initial use will be more fragmented than the four bands (850 MHz, 900 MHz, 1.8 GHz, 1.9 GHz) that enable global roaming on 2G and the additional two bands (1.7 GHz and 2.1 GHz) that enable 3G roaming. In the Americas, LTE roaming may occur in the 1.7/2.1 GHz (AWS) bands, and globally, LTE roaming may occur in the 2.6 GHz band. Longer term, operators will refarm spectrum used for 2G and 3G and apply it to LTE. Unfortunately, the process of identifying new spectrum and making it available for the industry is a lengthy one, as shown in Figure 22.

---

<sup>47</sup> FCC, *Mobile Broadband: The Benefits of Additional Spectrum*, October 2010.

**Figure 22: Spectrum Acquisition Time<sup>48</sup>**

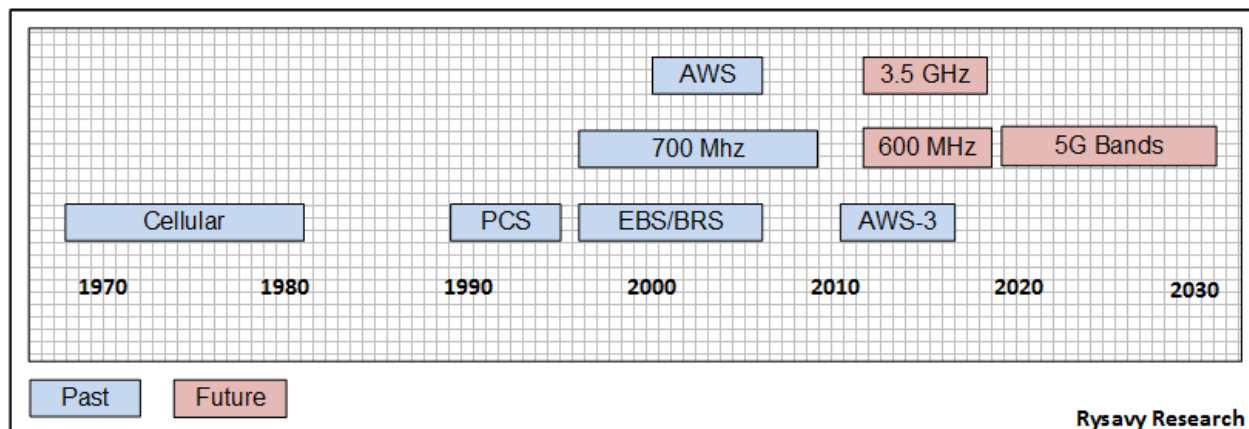

New short-term spectrum opportunities in the United States currently are incentive auctions of TV-broadcasting spectrum at 600 MHz and the “small-cell” band from 3550 to 3700 MHz.

Table 9 summarizes current and future spectrum allocations in the United States.<sup>49</sup>

**Table 9: United States Current and Future Spectrum Allocations**

Frequency Band	Amount of Spectrum	Comments
700 MHz	70 MHz	Ultra-High Frequency (UHF).
850 MHz	64 MHz	Cellular and Specialized Mobile Radio.
1.7/2.1 GHz	90 MHz	Advanced Wireless Services (AWS)-1.
1695-1710 MHz, 1755 to 1780 MHz, 2155 to 2180 MHz	65 MHz	AWS-3. Uses spectrum sharing.
1.9 GHz	140 MHz	Personal Communications Service (PCS).
2000 to 2020, 2180 to 2200 MHz	40 MHz	AWS-4 (Previously Mobile Satellite Service).

<sup>48</sup> Source for historical data, FCC, *National Broadband Plan*, Chapter 5. Available at <http://www.broadband.gov/plan/5-spectrum/>, accessed June 20, 2014. Future based on Rysavy Research analysis.

<sup>49</sup> For international allocations, refer to Wik-Consult, Study for the European Commission, *Inventory and review of spectrum use: Assessment of the EU potential for improving spectrum efficiency*, September 2012. Available at [http://ec.europa.eu/digital-agenda/sites/digital-agenda/files/cion\\_spectrum\\_inventory\\_executive\\_summary\\_en.pdf](http://ec.europa.eu/digital-agenda/sites/digital-agenda/files/cion_spectrum_inventory_executive_summary_en.pdf).

2.3 GHz	20 MHz	Wireless Communications Service (WCS).
2.5 GHz	194 MHz	Broadband Radio Service. Closer to 160 MHz deployable.
	<b>FUTURE</b>	
600 MHz	Up to 120 MHz	Incentive auctions.
3.55 to 3.70 GHz	150 MHz	Small-cell band with spectrum sharing and unlicensed use.
Above 5 GHz	Multi GHz	Anticipated for 5G systems in 2020 or later timeframe. Based on wavelengths, 3 GHz to 30 GHz is referred to as the cmWave band and 30 GHz to 300 GHz is referred to as the mmWave band.

Today's licensed-spectrum networks operate most efficiently and are deployed most cost-effectively using a combination of low-band spectrum, below 1 GHz, for coverage and 1 GHz to 3 GHz for capacity. As technology improves, bands in 3 GHz to 100 GHz, and eventually higher, will supplement capacity.

The subsections below provide additional information about the recently completed AWS-3 auction, incentive auctions, the 3.5 GHz, 5G, spectrum harmonization, unlicensed spectrum, and spectrum sharing.

## **AWS-3**

In early 2015, the FCC received close to \$45 billion for the U.S. Treasury in the AWS-3 auction, more than twice the amount of any previous auction, demonstrating the value of higher-band spectrum.<sup>50</sup> The auction adds 65 MHz of desirable spectrum to the mobile-broadband industry. The plan is to employ spectrum sharing among commercial networks and select government systems. Eventually, most of these government systems will migrate to other spectrum.

## ***Incentive Auctions (600 MHz)***

The incentive auctions will reallocate up to 120 MHz of UHF channels in the 600 MHz band that are currently used by TV broadcasters. The auctions, for which the FCC is currently developing rules, will be more complicated than past spectrum auctions, when the FCC simply reassigned or designated spectrum for commercial mobile use and then conducted an auction.

In the first stage, the FCC will conduct a reverse auction to determine how much spectrum broadcasters might wish to relinquish in exchange for how much compensation. It is unclear at this time how many broadcasters will participate and in what markets

---

<sup>50</sup> For further details, see Rysavy Research, "Latest FCC auction shatters spectrum myths," January 2015. Available at <https://gigaom.com/2015/01/17/latest-fcc-auction-shatters-spectrum-myths/>.

spectrum will be relinquished. The reverse auction is intended to provide answers to these unknowns, making it an unprecedented auction design.

In the second stage, mobile operators will bid for spectrum in a forward auction, similar to past spectrum auctions. The FCC currently hopes to conduct the auctions in 2016.<sup>51</sup>

Part of the auction process will be to reorganize and repack relinquished channels, as well as channels needed for broadcasters that want to keep broadcasting, to make useful blocks of spectrum for mobile broadband. The FCC's goal is to design an auction that will result in a uniform nationwide band plan, but in some markets there may be deviations from that plan.

### **3550 to 3700 MHz “Small-Cell” Band**

The 3550 to 3650 MHz band, with a recent extension of 3650 to 3700 MHz in the United States, is now also being discussed for licensing. The best use of this band will be small cells and backhaul. The FCC has proposed a three-tier model with incumbent access, priority access, and general authorized access.<sup>52</sup> Incumbent access will include government radar systems.

The mobile broadband industry will mostly use LTE in small-cell configurations, but operation of LTE in unlicensed bands is another potential use of the spectrum.

See the section “Spectrum Sharing” for further details of this band.

### **5G Bands**

As radio technology progresses, it can handle higher frequencies, and it occupies greater bandwidth. 1G systems used 30 kHz radio carriers, 2G in GSM uses 200 kHz carriers, 3G in UMTS uses 5 MHz carriers, and 4G in LTE uses carriers of up to 100 MHz through carrier aggregation.

Although 5G research and development is in its infancy, to achieve the 20 Gbps or higher throughput rates envisioned for 5G will require radio carriers of at least 1 GHz, bandwidths available only at frequencies above 5 GHz. Researchers globally are studying high-frequency spectrum options including both cmWave frequencies (3 GHz to 30 GHz) and mmWave (30 GHz to 300 GHz). Ten times as much spectrum, or more, could be available in these higher frequencies than in all current cellular spectrum.

---

<sup>51</sup> For further details, see FCC, Learn Program, “A Groundbreaking Event for the Broadcast Television, Mobile Wireless, and Technology Sectors of the U.S. Economy,” <http://wireless.fcc.gov/incentiveauctions/learn-program/> .

<sup>52</sup> For further details, see Official FCC Blog, “Innovation in the 3.5 GHz Band: Creating a New Citizens Broadband Radio Service,” March 2015, available at <http://www.fcc.gov/blog/innovation-35-ghz-band-creating-new-citizens-broadband-radio-service>. See also FCC, *Further Notice of Proposed Rulemaking--Amendment of the Commission's Rules with Regard to Commercial Operations in the 3550- 3650 MHz Band*, April 23, 2014.

In 2014, the FCC published a Notice of Inquiry into use of spectrum bands above 24 GHz for Mobile Radio Services.<sup>53</sup> This inquiry seeks comments on a number of potential bands for 5G, including:

- ❑ 24 GHz Bands: 24.25-24.45 GHz and 25.05-25.25 GHz.
- ❑ Local Multipoint Distribution Service (LMDS) Band: 27.5-28.35 GHz, 29.1-29.25 GHz, and 31-31.3 GHz.
- ❑ 39 GHz Band: 38.6-40 GHz.
- ❑ 37/42 GHz Bands: 37.0-38.6 GHz and 42.0-42.5 GHz.
- ❑ 60 GHz Bands: 57-64 GHz and 64-71 GHz.
- ❑ 70/80 GHz Bands: 71-76 GHz, 81-86 GHz.

The 5G organization Mobile and wireless communications Enablers for the Twenty-twenty Information Society (METIS) has published a report on spectrum needs that evaluates the following frequency bands:

- ❑ 380 to 5925 MHz (current systems)
- ❑ 5.925 MHz to 40.5 GHz
- ❑ 40.5 GHz to 95 GHz
- ❑ 95 GHz to 275 GHz (representing the upper limits of mmWave bands)<sup>54</sup>

## **Harmonization**

Spectrum harmonization delivers many benefits, including higher economies of scale, better battery life, improved roaming, and reduced interference along borders.

As regulators make more spectrum available, it is important that they follow guidelines such as those espoused by 4G Americas<sup>55</sup>:

1. Configure licenses with wider bandwidths.
2. Group like services together.
3. Be mindful of global technology standards.
4. Pursue harmonized/contiguous spectrum allocations.
5. Exhaust exclusive use options before pursuing shared use.
6. Because not all spectrum is fungible, align allocation with demand.

---

<sup>53</sup> FCC, *Notice of Inquiry, Use of Spectrum Bands above 24 GHz for Mobile Radio Services*, Oct. 17, 2014.

<sup>54</sup> METIS, *Deliverable D5.1, Intermediate description of the spectrum needs and usage principles*, Aug 2013. Available at [https://www.metis2020.com/wp-content/uploads/deliverables/METIS\\_D5.1\\_v1.pdf](https://www.metis2020.com/wp-content/uploads/deliverables/METIS_D5.1_v1.pdf).

<sup>55</sup> 4G Americas, *Sustaining the Mobile Miracle – A 4G Americas Blueprint for Securing Mobile Broadband Spectrum in this Decade*, March 2011.



Emerging technologies such as LTE benefit from wider radio channels. These wider channels are not only spectrally more efficient, they also offer greater capacity. Figure 23 shows increasing LTE spectral efficiency obtained with wider radio channels, with 20 MHz on the downlink and 20 MHz (20+20 MHz) on the uplink comprising the most efficient configuration.

**Figure 23: LTE Spectral Efficiency as Function of Radio Channel Size<sup>56</sup>**

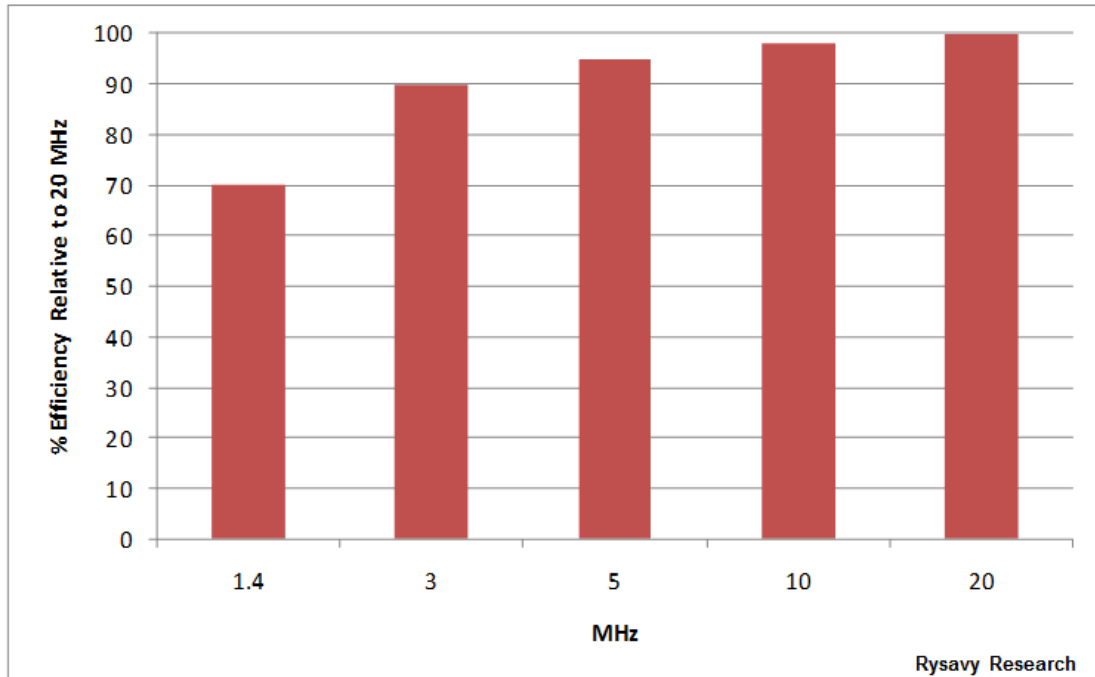

The organization tasked with global spectrum harmonization, the International Telecommunication Union, periodically holds World Radiocommunication Conferences (WRC).<sup>57</sup>

Harmonization occurs at multiple levels:

- ❑ Allocation of radio frequencies to a mobile service in the ITU frequency allocation table.
- ❑ Establishment of global or regional frequency arrangements, including channel blocks and specific duplexing modes.
- ❑ Development of detailed technical specifications and standards, including system performance, RF performance, and coexistence with other systems in neighboring bands.

---

<sup>56</sup> 4G Americas member company analysis.

<sup>57</sup>International Telecommunication Union, "World Radiocommunication Conferences (WRC)," <http://www.itu.int/ITU-R/index.asp?category=conferences&mlink=wrc&lang=en>, accessed June 20, 2014.

- Assignment for frequency blocks with associated technical conditions and specifications to appropriate operators and service providers.<sup>58</sup>

Figure 24 shows the harmonization process.

**Figure 24: Spectrum Harmonization<sup>59</sup>**

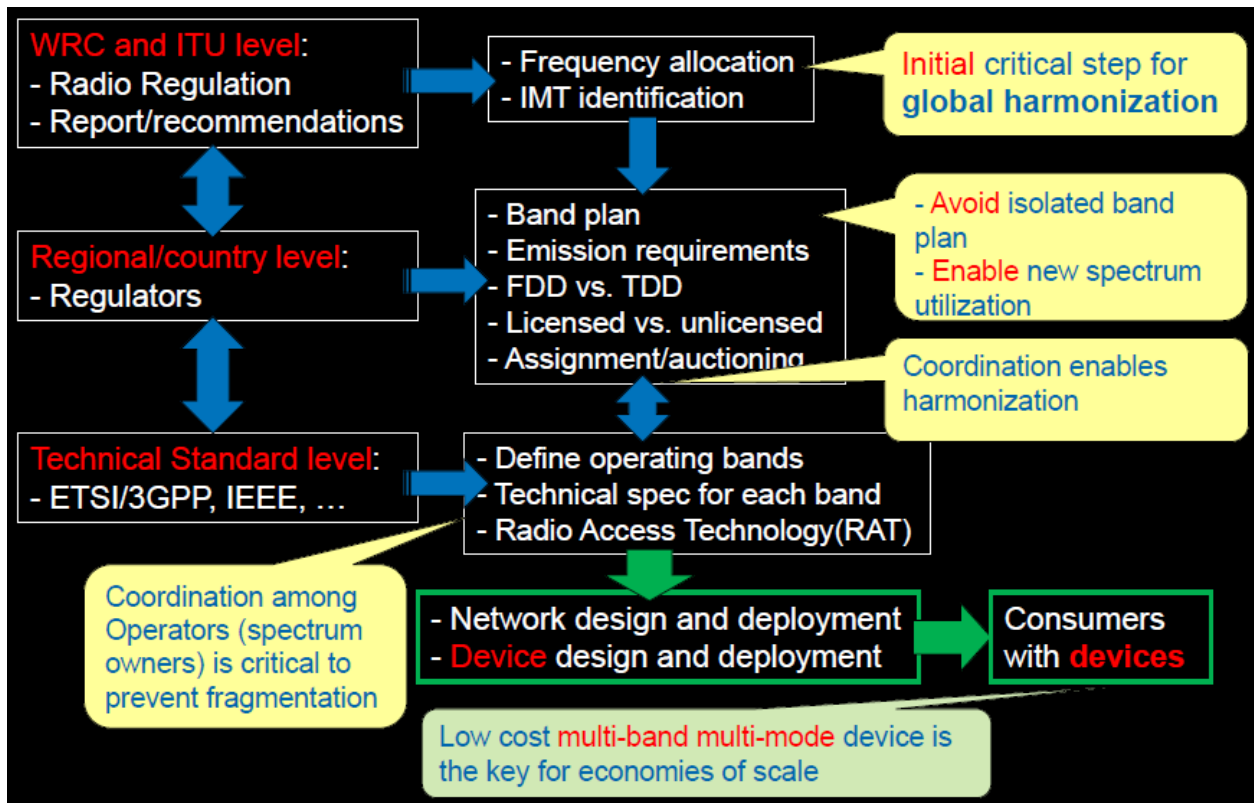

The ITU WRC is planning its next conference for November 2015.<sup>60</sup> The WRC 2015 and subsequent 2019 conferences will address spectrum above 6 GHz for 5G.

## Unlicensed Spectrum

Wi-Fi, an unlicensed wireless technology, has experienced huge success due to high throughput rates, ease of use for consumers, extensive deployment by businesses, widespread availability in public places, and large amounts of available spectrum. Now, 3GPP is preparing a version of LTE that can also operate in unlicensed spectrum, which

<sup>58</sup> International Telecommunication Union Radiocommunication Study Groups, *Technical Perspective On Benefits Of Spectrum Harmonization for Mobile Services and IMT*, Document 5D/246-E, January 2013.

<sup>59</sup> 4G Americas member contribution.

<sup>60</sup> Agenda available at [http://www.itu.int/dms\\_pub/itu-r/oth/12/01/R12010000014A01PDFE.pdf](http://www.itu.int/dms_pub/itu-r/oth/12/01/R12010000014A01PDFE.pdf). Accessed June 20, 2014. See also <http://www.itu.int/en/ITU-R/conferences/wrc/2015/Pages/default.aspx>.

will provide an alternate means for operators to harness unlicensed spectrum, as discussed above in the section “Unlicensed Spectrum Integration.”

Wi-Fi uses spectrum efficiently because its small coverage areas result in high-frequency reuse and high data density (bps per square meter). Less efficient are white-space unlicensed networks, sometimes called “super Wi-Fi,” that have large coverage areas, because the throughput per square meter is much lower. While white-space networks may be a practical broadband solution in rural or undeveloped areas, they face significant challenges in urban areas that already have mobile and fixed broadband available.<sup>61</sup> See the section on “White Space Networks” in the appendix for further details.

Advocates argue that unlicensed spectrum unleashes innovation and that government should allocate greater amounts of unlicensed spectrum. Although Wi-Fi has been successful, the core elements that make unlicensed spectrum extremely successful are also the source of inherent disadvantages: local coverage and its unlicensed status. Local coverage enables high data density and high frequency reuse but makes widespread continuous coverage almost impossible. Similarly, unlicensed operation facilitates deployment by millions of entities but results in overlapping coverage and interference.

Networks built using unlicensed spectrum cannot replace networks built using licensed spectrum. The two are complementary and helpful to each other, as summarized in Table 10.<sup>62</sup>

**Table 10: Pros and Cons of Unlicensed and Licensed Spectrum**

Unlicensed Pros	Unlicensed Cons	Licensed Pros	Licensed Cons
Easy and quick to deploy	Potential of other entities using same frequencies	Huge coverage areas	Expensive infrastructure
Low-cost hardware	Difficult to impossible to provide wide-scale coverage	Able to manage quality of service	Each operator has access to only a small amount of spectrum

Some operators offer a “Wi-Fi first” capability under which devices always attempt to use a Wi-Fi connection and fall back to a cellular connection only if no Wi-Fi is available. Such cellular backup is essential because Wi-Fi, due to low-power operation in many bands, is inherently unsuited for providing continuous coverage. The sharp drop-off in signal strength makes coverage gaps over large areas inevitable, especially outdoors.

---

<sup>61</sup> For further analysis, see Rysavy Research, “White spaces networks are not ‘super’ nor even Wi-Fi,” Gigaom, March 2013. Available at <http://gigaom.com/2013/03/17/white-spaces-networks-are-not-super-nor-even-wi-fi/>.

<sup>62</sup> For further analysis, see Rysavy Research, “It’s Time for a Rational Perspective on Wi-Fi,” Gigaom, April, 2014. Available at <http://gigaom.com/2014/04/27/its-time-for-a-rational-perspective-on-wi-fi/>.

**Figure 25: Propagation Losses of Cellular vs. Wi-Fi<sup>63</sup>**

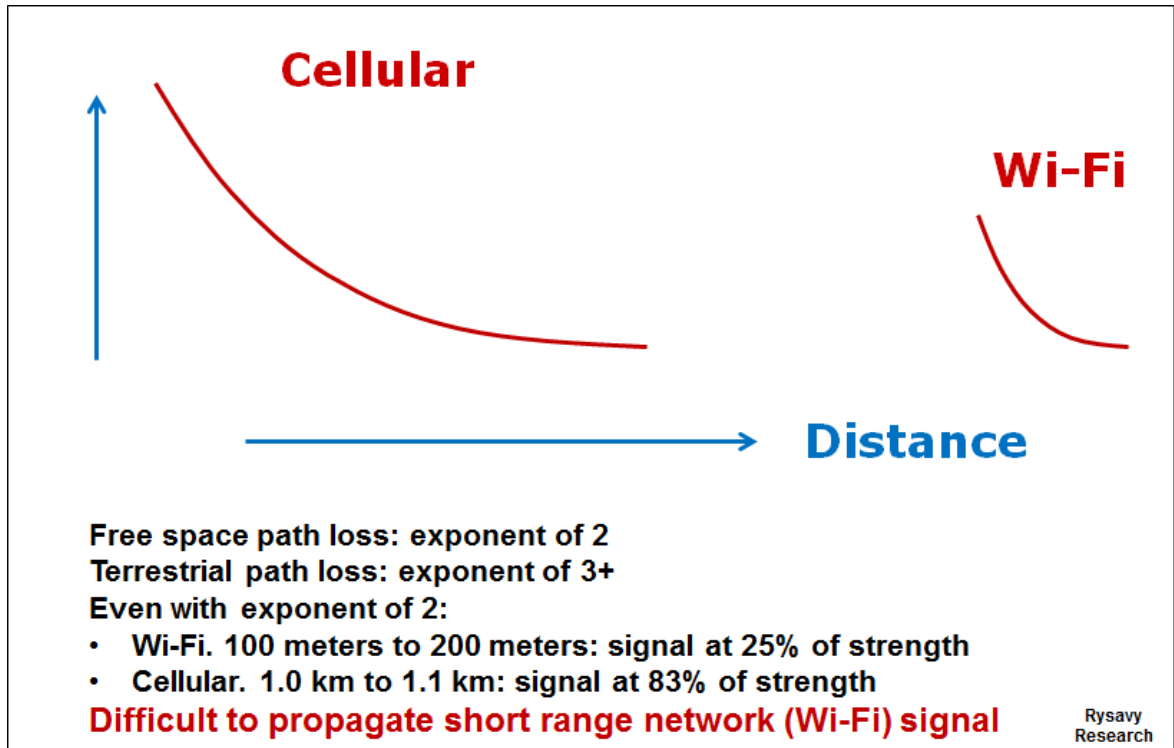

## ***Spectrum Sharing***

In 2012, the President’s Council of Advisors on Science and Technology issued a report titled, “Realizing the Full Potential of Government-Held Spectrum to Spur Economic Growth.” The report recommended spectrum sharing between government and commercial entities.

On the surface, spectrum sharing between a government application, such as radar or satellite, and a commercial network appears to be efficient, especially if the government application operates in only some areas or only some of the time. From a technical perspective, sharing may eventually lead to more efficient spectrum use; however, many challenges remain to be solved. Excessive emphasis on sharing in the short term could needlessly slow deployment and use of productive spectrum.

The U.S. government can designate spectrum for exclusive, shared, or unlicensed use, as shown in Figure 26. Shared use can be opportunistic, as with TV white spaces; two-tier with incumbents and licensed users; or three tier, which adds opportunistic access. The bands initially targeted for spectrum sharing include AWS-3 (two tiers on a temporary basis) and the 3.5 GHz band (three tiers).

The three-tier plan envisioned by the U.S. government for the 3.5 GHz band gives more entities access to the spectrum but at the cost of increased complexity.

---

<sup>63</sup> Assumes 1.0 km radius for cellular and 100 meter radius for Wi-Fi.

**Figure 26: Spectrum Use and Sharing Approaches**

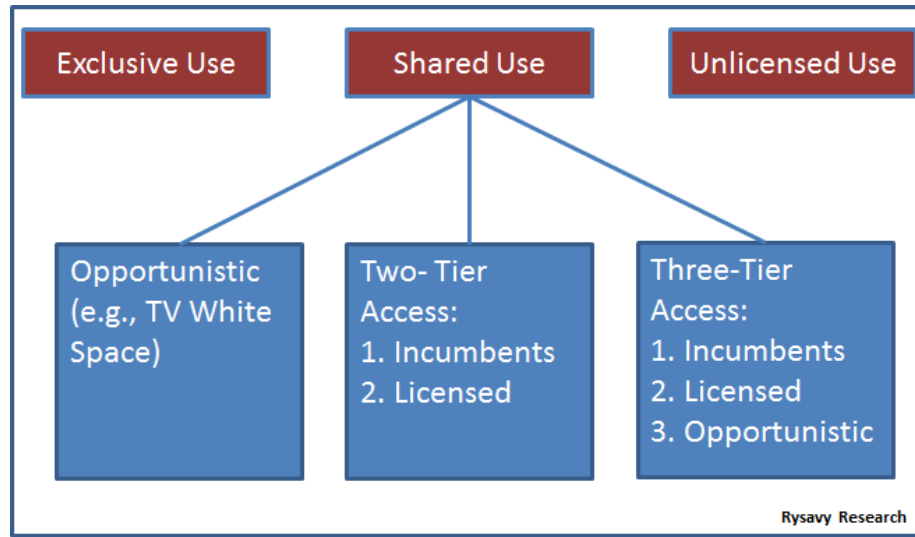

The European Telecommunications Standards Institute (ETSI) is the leading organization standardizing cognitive radios. The most relevant effort is called Licensed Shared Access (LSA), a two-tier spectrum sharing system that includes incumbents and licensed secondary users that access shared spectrum via a database, as depicted in Figure 27.

**Figure 27: Licensed Shared Access (LSA)**

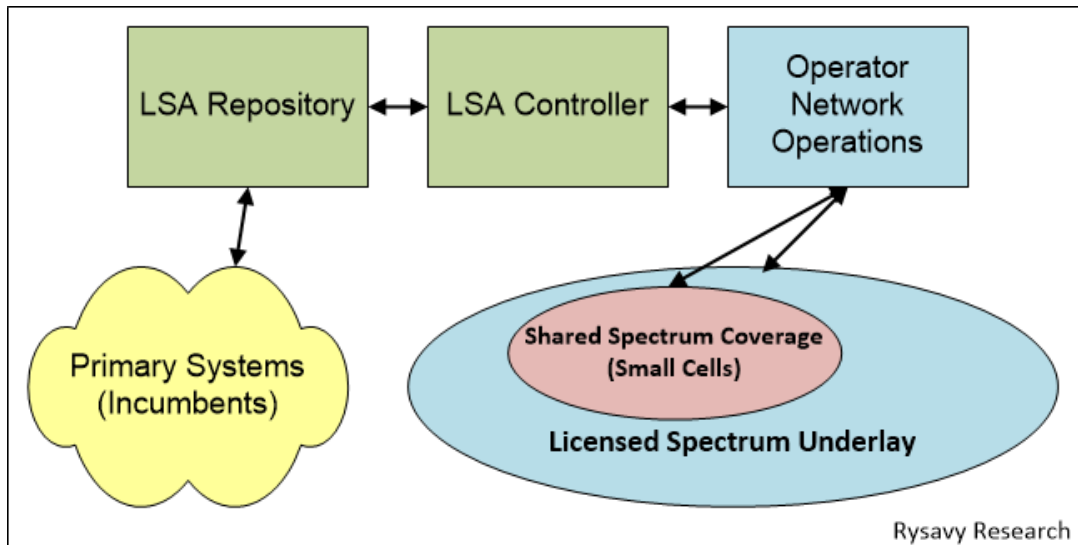

The three-tier system expected for the 3.5 GHz band in the United States will be complex, necessitating a real-time Spectrum Access System, the SAS, the design and development of which will encompass:

- ❑ Algorithms and methods;
- ❑ Methods of nesting hierarchical SAS entities (federal secure SAS versus commercial SASs);

- ❑ Coordination among multiple, competing commercial SAS managing entities;
- ❑ Interface definitions;
- ❑ Communication protocol definitions;
- ❑ Database and protocol security;
- ❑ Policy enforcement;
- ❑ Speed of channel allocation/reallocation;
- ❑ Time intervals for spectrum allocation;
- ❑ Effectively managing large numbers of Tier 3 users; and
- ❑ Data ownership, fees, rules, fairness, and conflict resolutions, all of which have policy, regulatory, and business implications.

TVWS databases available today address only a tiny subset of these requirements.<sup>64</sup>

Figure 28 shows the proposed architecture of the 3.5 GHz system. The system consists of incumbents (government systems), Priority Access Licenses (PAL), and General Authorized Access (GAA). Government systems include military ship-borne radar, military ground-based radar, fixed-satellite service earth stations (receive only), and government broadband services (3650 to 3700 MHz). PAL licenses will be used by entities such as cellular operators and will be available for three-year periods. GAA users are licensed by rule and must protect both incumbents and PALs. Some examples of GAA use cases are small-business hotspots, campus hotspots, and backhaul.

Citizens Broadband Radio Service Devices (CBSDs) are the base stations operating under this service; they can operate only under the authority and management of the SAS, either by direct communications or a proxy node.

---

<sup>64</sup> For further analysis, see Rysavy Research and Mobile Future, *Complexities of Spectrum Sharing: How to Move Forward*, April 2014. Available at <http://www.rysavy.com/Articles/2014-04-Spectrum-Sharing-Complexities.pdf>.

**Figure 28: United States 3.5 GHz System Currently Being Developed**

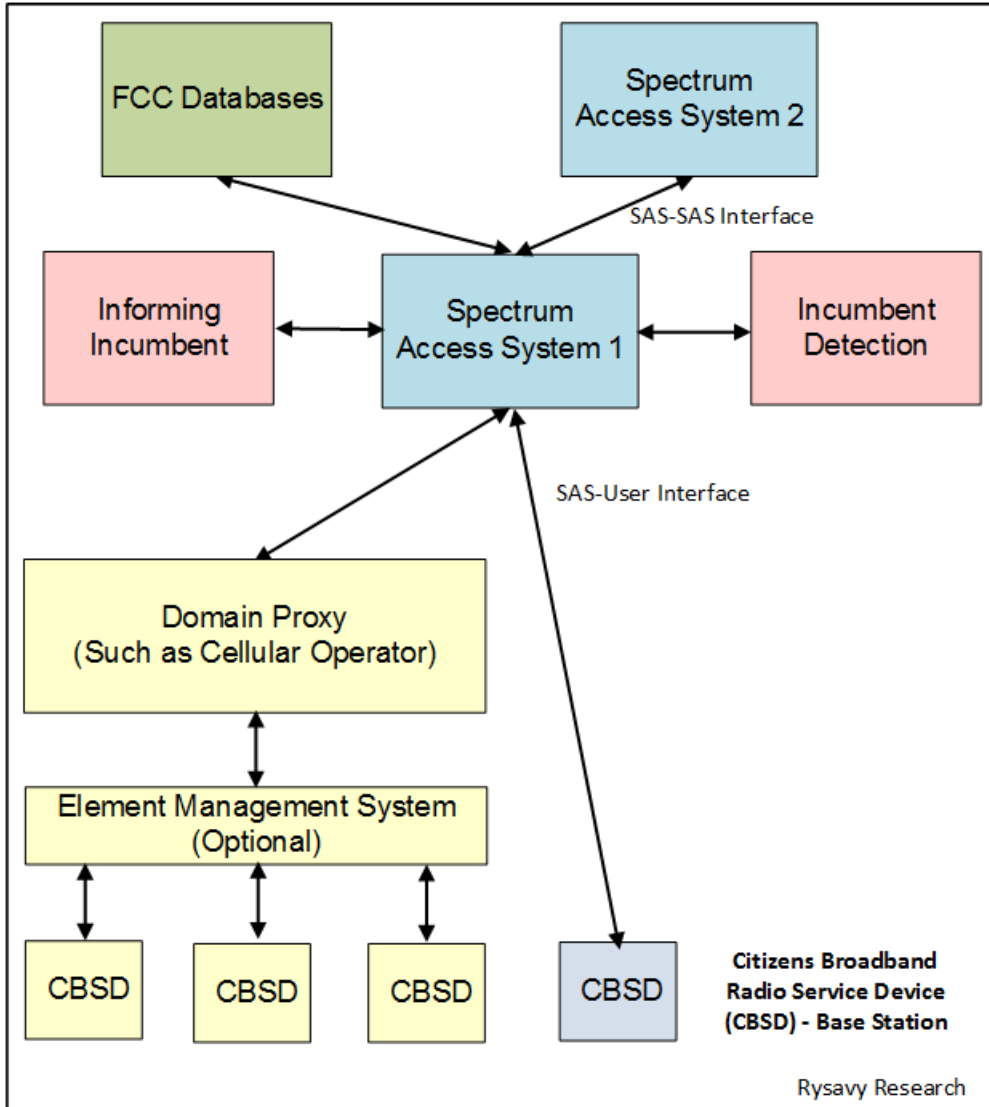

## Conclusion

Mobile broadband remains at the forefront of innovation and development in computing, networking, and application development. As users, and now machines, consume ever more wireless data, the industry is responding with more efficient, faster, and higher-capacity networks. The key technology is LTE, which has become a global wireless foundation, supporting continual enhancements, and into which 5G will be integrated next decade. The United States continues to lead the world in LTE deployment.

LTE-Advanced innovations include carrier aggregation, already in use, and eICIC, SON, and CoMP, all capabilities about to be unleashed that will improve performance, efficiency, and capacity. Carriers are also beginning to deploy NFV and SDN to reduce network costs and simplify deployment of new services. Such improvements also facilitate cloud RANs that promise further efficiency gains.

Small cells could play an ever-more-important role in boosting capacity, benefiting from a number of developments, including SON, eICIC, improved backhaul options, spectrum intended for small cells such as 3.5 GHz, LWA, LTE-U, and LTE-LAA. Improved Wi-Fi integration techniques provide another avenue to increase capacity. Obtaining more spectrum remains a critical priority globally. In U.S. markets, a number of initiatives hold promise—television incentive auctions for 600 MHz spectrum, the 3.5 GHz small-cell band, more unlicensed spectrum at 5GHz—but only if government implements appropriate policy measures that maximize auction participation and resists implementing unrealistic spectrum-sharing requirements.

5G research and development efforts have accelerated, and deployment could commence close to 2020 and continue through 2030. Still, much work needs to be done before 5G becomes a reality and is able to reach the potential of recent press-release promises. By harnessing new spectrum, such as mmWave bands above 30 GHz, 5G might be able to access ten times as much spectrum as is currently available for cellular operation. Using radio bands 1 GHz or wider will result in multi-Gbps throughput capabilities. 5G will be designed to integrate with LTE networks, and many 5G features may be implemented as LTE-Advanced extensions prior to full 5G availability.

The future of mobile broadband, including both LTE-Advanced and 5G, is bright, with no end in sight for continued growth in capability, nor for the limitless application innovation that mobile broadband enables.



## Appendix: Technology Details

The 3GPP family of data technologies provides ever increasing capabilities that support ever more demanding applications. Services obviously need to provide broad coverage and high data throughput. Less obvious for users, but as critical for effective application performance, are the need for low latency, QoS control, and spectral efficiency. Higher spectral efficiency translates to higher average throughputs (and thus more responsive applications) for more active users in a coverage area. The discussion below details the progression of capability for each technology, including throughput, security, latency, QoS, and spectral efficiency.

This appendix provides details on UMTS/WCDMA, HSPA+, LTE, LTE-Advanced, HetNets, EPC, Wi-Fi integration, IMS, broadcast/multicast services, backhaul, UMTS TDD, Time-Division Synchronous Code Division Multiple Access (TD-SCDMA), EDGE, and TV white spaces.

### ***Data Throughput Comparison***

Data throughput is an important metric for quantifying network throughput performance. Unfortunately, the ways in which various organizations quote throughputs vary tremendously, often resulting in misleading claims. The intent of this paper is to realistically represent the capabilities of these technologies.

One method of representing a technology's throughput is what people call "peak throughput" or "peak network speed," which refers to the fastest possible transmission speed over the radio link and is generally based on the highest-order modulation available and the least amount of coding (error correction) overhead. Peak network speed is also usually quoted at layer 2 of the radio link. Because of protocol overhead, actual application throughput may be up to 10% lower than this layer-2 value.

Another method is to disclose throughputs actually measured in deployed networks with applications such as File Transfer Protocol (FTP) under favorable conditions, which assume light network load (as low as one active data user in the cell sector) and favorable signal propagation. This number is useful because it demonstrates the high-end, actual capability of the technology in current deployments, referred to in this paper as the "peak user rate." Average rates are lower than this peak rate and are difficult to predict because they depend on a multitude of operational and network factors. Except when the network is congested, however, the majority of users should experience throughput rates higher than one-half of the peak achievable rate.

Some operators, primarily in the United States, also quote typical throughput rates, which are based on throughput tests the operators have done across their operating networks and incorporate a higher level of network load. Although the operators do not disclose the precise methodologies they use to establish these figures, the values provide a good indication of what users can realistically expect.

Table 11 presents the technologies in terms of peak network throughput rates, peak user rates (under favorable conditions), and typical rates. It omits values that are not yet known, such as for future technologies.

The projected typical rates for HSPA+ and LTE show a wide range because these technologies exploit favorable radio conditions to achieve high throughput rates, but under poor radio conditions, throughput rates are lower.

**Table 11: Throughput Performance of Different Wireless Technologies (Blue Indicates Theoretical Peak Rates, Green Typical)**

	Downlink		Uplink	
	Peak Network Speed	Peak and/or Typical User Rate	Peak Network Speed	Peak and/or Typical User Rate
<b>EDGE (type 2 MS)</b>	473.6 Kbps	Not Applicable (N/A)	473.6 Kbps	N/A
<b>EDGE (type 1 MS) (Practical Terminal)</b>	236.8 Kbps	200 Kbps peak 160 to 200 Kbps typical <sup>65</sup>	236.8 Kbps	200 Kbps peak 80 to 160 Kbps typical <sup>66</sup>
<b>HSDPA Initial Devices (2006)</b>	1.8 Mbps	> 1 Mbps peak	384 Kbps	350 Kbps peak
<b>HSDPA</b>	14.4 Mbps	N/A	384 Kbps	N/A
<b>HSPA<sup>67</sup> Initial Implementation</b>	7.2 Mbps	> 5 Mbps peak 700 Kbps to 1.7 Mbps typical <sup>68</sup>	2 Mbps	> 1.5 Mbps peak 500 Kbps to 1.2 Mbps typical
<b>HSPA</b>	14.4 Mbps	N/A	5.76 Mbps	N/A
<b>HSPA+ (DL 64 QAM, UL 16 QAM, 5+5 MHz)</b>	21.6 Mbps	1.9 Mbps to 8.8 Mbps typical <sup>69</sup>	11.5 Mbps	1 Mbps to 4 Mbps typical

<sup>65</sup> Assumes four-to-five downlink timeslot devices (each timeslot capable of 40 Kbps).

<sup>66</sup> Assumes two-to-four uplink timeslot devices (each timeslot capable of 40 Kbps).

<sup>67</sup> High Speed Packet Access (HSPA) consists of systems supporting both High Speed Downlink Packet Access (HSDPA) and High Speed Uplink Packet Access (HSUPA).

<sup>68</sup> Typical downlink and uplink throughput rates based on AT&T press release, June 4, 2008

	Downlink		Uplink	
	Peak Network Speed	Peak and/or Typical User Rate	Peak Network Speed	Peak and/or Typical User Rate
<b>HSPA+ (2X2 MIMO, DL 16 QAM, UL 16 QAM, 5+5 MHz)</b>	28 Mbps	N/A	11.5 Mbps	N/A
<b>HSPA+ (2X2 MIMO, DL 64 QAM, UL 16 QAM, 5+5 MHz)</b>	42 Mbps	N/A	11.5 Mbps	N/A
<b>HSPA+ (DL 64 QAM, UL 16 QAM, Dual Carrier, 10+5 MHz)</b>	42 Mbps	Approximate doubling of 5+5 MHz rates - 3.8 to 17.6 Mbps.	11.5 Mbps	1 Mbps to 4 Mbps typical
<b>HSPA+ (2X2 MIMO DL, DL 64 QAM, UL 16 QAM, Dual Carrier, 10+10 MHz)</b>	84 Mbps	N/A	23 Mbps	N/A
<b>HSPA+ (2X2 MIMO DL, DL 64 QAM, UL 16 QAM, Quad Carrier<sup>70</sup>, 20+10 MHz)</b>	168 Mbps	N/A	23 Mbps	N/A
<b>HSPA+ (2X2 MIMO DL and UL, DL 64 QAM, UL 16 QAM, Eight Carrier, 40+10 MHz)</b>	336 Mbps	N/A	69 Mbps	N/A
<b>HSPA+ (4X2 MIMO DL, 2X2 MIMO UL, DL 64 QAM, UL 16 QAM, 8 carrier, 40+10 MHz)</b>	672 Mbps	N/A	69 Mbps	N/A

<sup>69</sup> 4G Americas member company analysis. Assumes Release 7 with 64 QAM and F-DPCH. Single user. 50% loading in neighboring cells. Higher rates expected with subsequent 3GPP releases.

<sup>70</sup> No operators have announced plans to deploy HSPA in a quad (or greater) carrier configuration. Three carrier configurations, however, have been deployed.

	Downlink		Uplink	
	Peak Network Speed	Peak and/or Typical User Rate	Peak Network Speed	Peak and/or Typical User Rate
<b>LTE (2X2 MIMO, 10+10 MHz)</b>	70 Mbps	6.5 to 26.3 Mbps <sup>71</sup>	35 Mbps <sup>72</sup>	6.0 to 13.0 Mbps
<b>LTE (4X4 MIMO, 20+20 MHz)</b>	300 Mbps	N/A	71 Mbps <sup>73</sup>	N/A
<b>LTE Advanced (8X8 MIMO, 20+20 MHz, DL 64 QAM, UL 64 QAM)</b>	1.2 Gbps	N/A	568 Mbps	N/A
<b>CDMA2000 EV-DO Rel. 0</b>	2.4 Mbps	> 1 Mbps peak	153 Kbps	150 Kbps peak
<b>CDMA2000 EV-DO Rev. A</b>	3.1 Mbps	> 1.5 Mbps peak 600 Kbps to 1.4 Mbps typical <sup>74</sup>	1.8 Mbps	> 1 Mbps peak 300 to 500 Kbps typical
<b>CDMA2000 EV-DO Rev. B (3 radio channels 5+5 MHz)</b>	14.7 <sup>75</sup> Mbps	Proportional increase of Rev A typical rates based on number of carriers.	5.4 Mbps	N/A
<b>CDMA2000 EV-DO Rev B Theoretical (15 radio channels 20+20 MHz)</b>	73.5 Mbps	N/A	27 Mbps	N/A

<sup>71</sup> 4G Americas member company analysis for downlink and uplink. Assumes single user with 50% load in other sectors. AT&T and Verizon are quoting typical user rates of 5-12 Mbps on the downlink and 2-5 Mbps on the uplink for their networks. See additional LTE throughput information in the section below, "LTE Throughput."

<sup>72</sup> Assumes 64 QAM. Otherwise 22 Mbps with 16 QAM.

<sup>73</sup> Assumes 64 QAM. Otherwise 45 Mbps with 16 QAM.

<sup>74</sup> Typical downlink and uplink throughput rates based on Sprint press release Jan. 30, 2007.

<sup>75</sup> Assuming use of 64 QAM.

Additional information about LTE throughput appears below in the section, "LTE Throughput."

## Latency Comparison

As important as throughput is network latency, defined as the round-trip time it takes data to traverse the network. Each successive data technology from GPRS forward reduces latency, with LTE networks having latency as low as 15 msec. Ongoing improvements in each technology mean that all of these values will go down as vendors and operators fine-tune their systems. Figure 29 shows the latency of different 3GPP technologies.

**Figure 29: Latency of Different Technologies<sup>76</sup>**

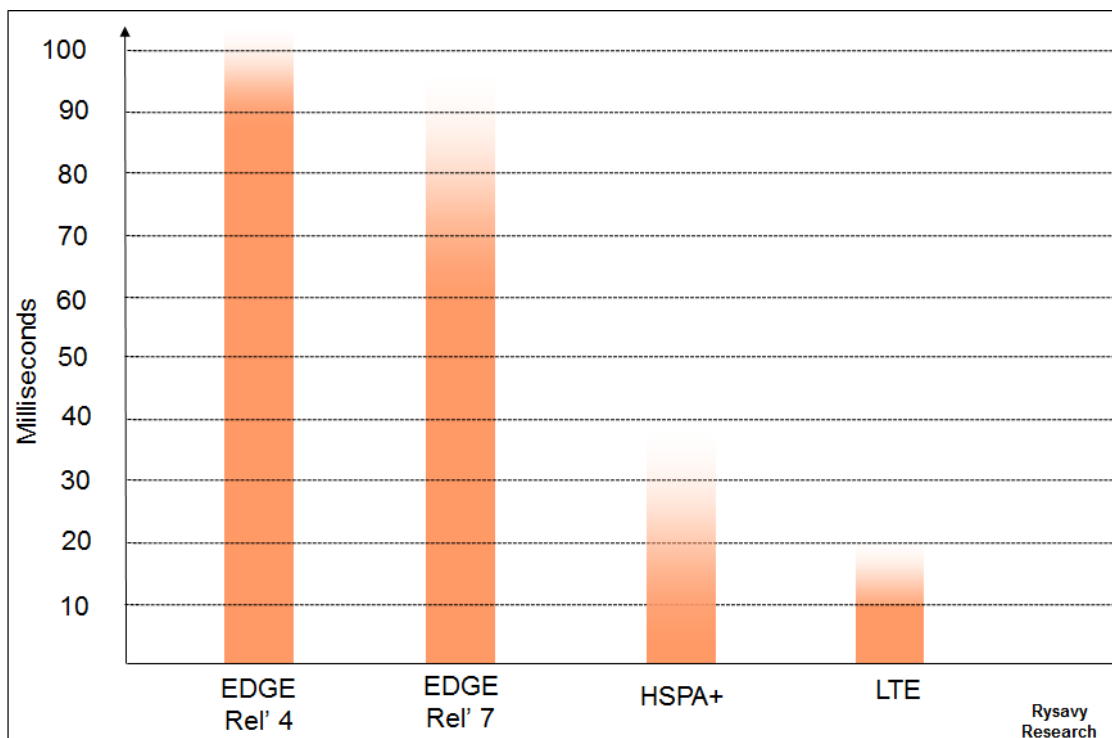

The values shown in Figure 29 reflect measurements of commercially deployed technologies, with EDGE Release 4 having sub-100-msec latency, EDGE Release 7 achieving 70 to 95 msec, HSPA+ 25 to 30 msec, and LTE 15 to 20 msec. One goal of 5G is less than 1 msec latency.

## Spectral Efficiency

The evolution of data services is characterized by an increasing number of users with ever-higher bandwidth demands. As the wireless data market grows, deploying wireless

---

<sup>76</sup> 4G Americas member companies. Measured between subscriber unit and a node immediately external to wireless network. Does not include Internet latency. Note that there is some variation in latency based on network configuration and operating conditions.

technologies with high spectral efficiency is of paramount importance. Keeping all other things equal, including frequency band, amount of spectrum, and cell site spacing, an increase in spectral efficiency translates to a proportional increase in the number of users supported at the same load per user—or, for the same number of users, an increase in throughput available to each user.

Increased spectral efficiency, however, comes at a price because it generally involves greater complexity for both user and base station equipment. Complexity can arise from the increased number of calculations performed to process signals or from additional radio components. Hence, operators and vendors must balance market needs against network and equipment costs. OFDMA technologies are attractive because they achieve higher spectral efficiency with lower overall complexity, especially in larger bandwidths.

As shown in Figure 30, the link layer performance of today’s wireless technologies is approaching the theoretical limits as defined by the Shannon bound. (The Shannon bound is a theoretical limit to the information transfer rate [per unit bandwidth] that can be supported by any communications link. The bound is a function of the SNRs of the communications link.) Figure 30 also shows that HSDPA, 1xEV-DO, and IEEE 802.16e-2005 are all within 2 to 3 decibels (dB) of the Shannon bound, indicating that there is not much room for improvement from a link-layer perspective.

**Figure 30: Performance Relative to Theoretical Limits for HSDPA, EV-DO, and IEEE 802.16e-2005<sup>77</sup>**

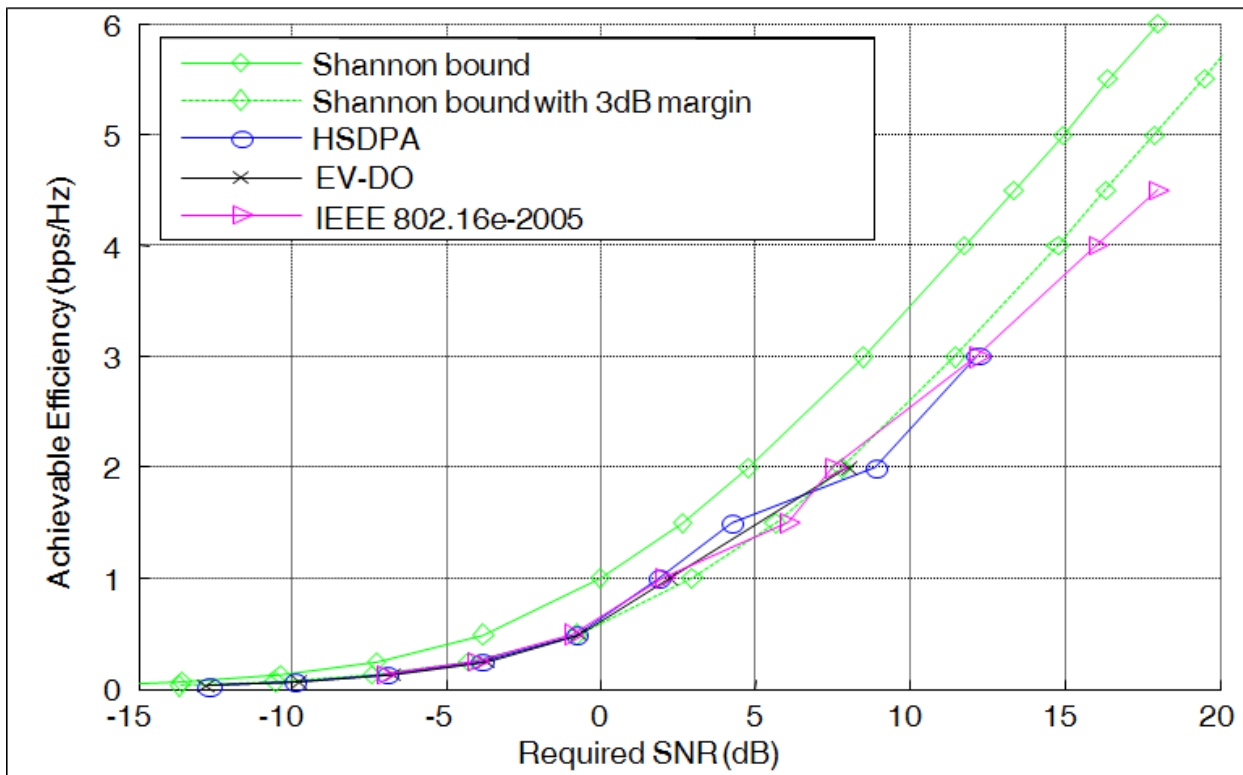

<sup>77</sup> 4G Americas member contribution.

The curves in Figure 30 are for an Additive White Gaussian Noise Channel (AWGN). If the channel is slowly varying and the frame interval is significantly shorter than the coherence time, the effects of fading can be compensated for by practical channel estimation algorithms—thus justifying the AWGN assumption. For instance, at 3 km per hour and fading at 2 GHz, the Doppler spread is about 5.5 Hz. The coherence time of the channel is thus 1 second (sec)/5.5 or 180 msec. Frames are well within the coherence time of the channel, because they are typically 20 msec or less. As such, the channel appears “constant” over a frame, and the Shannon bound applies. Furthermore, significantly more of the traffic in a cellular system is at slow speeds (for example, 3 km/hr. or less) rather than at higher speeds. The Shannon bound is consequently also relevant for a realistic deployment environment.

As the speed of the mobile station increases and the channel estimation becomes less accurate, additional margin is needed. This additional margin, however, would impact the different standards fairly equally.

The focus of future technology enhancements is on improving system performance aspects that reduce interference to maximize the experienced SNRs in the system and antenna techniques (such as MIMO) that exploit multiple links rather than on investigating new air interfaces that attempt to improve link-layer performance.

MIMO techniques using spatial multiplexing to increase the overall information transfer rate by a factor proportional to the number of transmit or receive antennas do not violate the Shannon bound because the per-antenna transfer rate (that is, the per-communications link transfer rate) is still limited by the Shannon bound.

Figure 31 compares the spectral efficiency of different wireless technologies based on a consensus view of 4G Americas contributors to this paper. It shows the continuing evolution of the capabilities of all the technologies discussed. The values shown are reasonably representative of real-world conditions. Most simulation results produce values under idealized conditions; as such, some of the values shown are lower (for all technologies) than the values indicated in other papers and publications. For instance, 3GPP studies indicate higher HSDPA and LTE spectral efficiencies. Nevertheless, there are practical considerations in implementing technologies that can prevent actual deployments from reaching calculated values. Consequently, initial versions of technology may operate at lower levels but then improve over time as designs are optimized. Therefore, readers should interpret the values shown as achievable, but not as the actual values that might be measured in any specific deployed network.



**Figure 31: Comparison of Downlink Spectral Efficiency<sup>78</sup>**

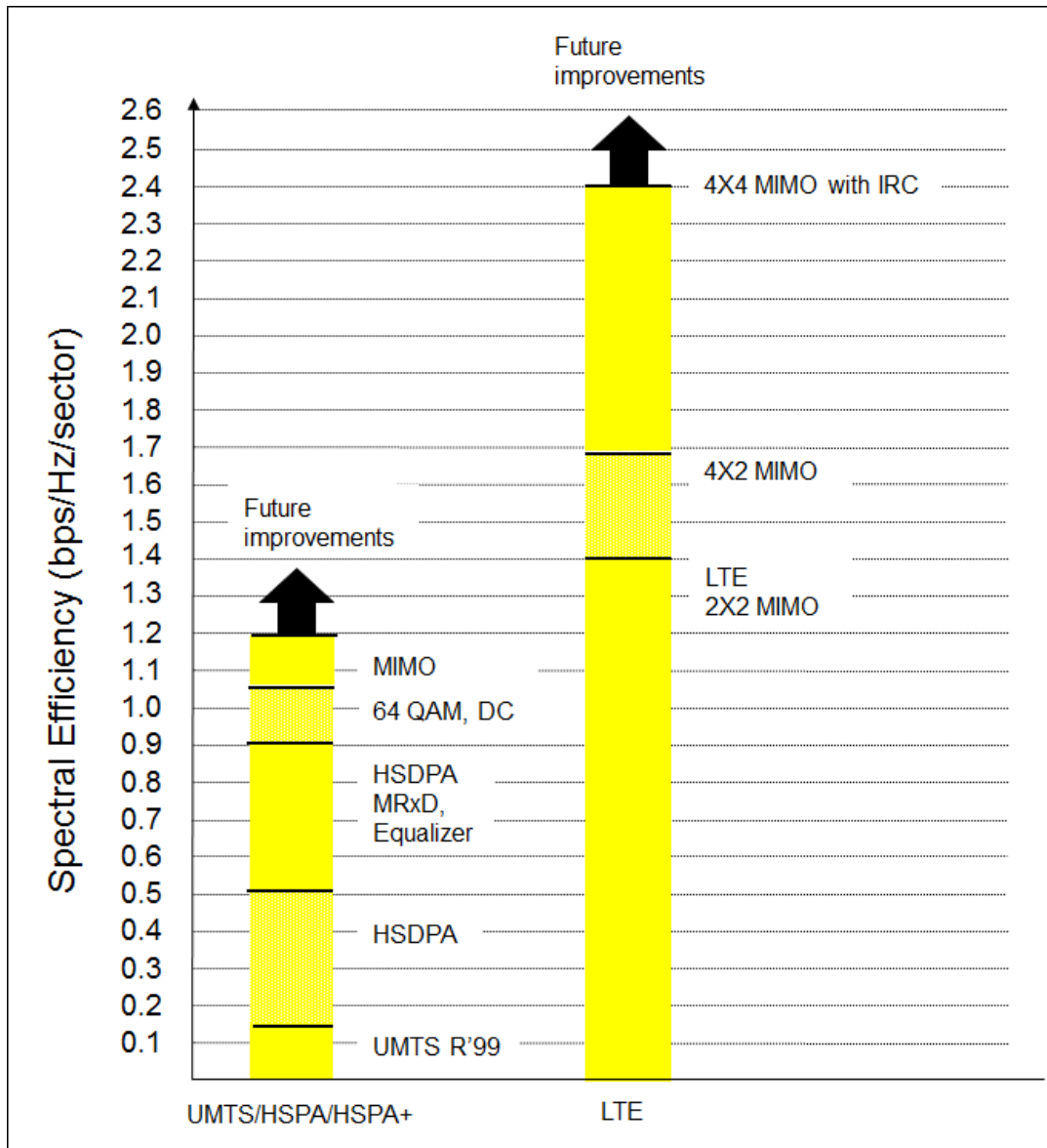

The values shown in Figure 31 are not all possible combinations of available features. Rather, they are representative milestones in ongoing improvements in spectral efficiency. For instance, there are terminals that employ mobile-receive diversity but not equalization.

The figure does not include EDGE, but EDGE itself is spectrally efficient at 0.6 bps/Hz using mobile receive diversity and, potentially, 0.7 bps/Hz with MIMO. Relative to

<sup>78</sup> Joint analysis by 4G Americas members. 5+5 MHz FDD for UMTS-HSPA/LTE and CDMA2000, and 10 MHz TDD DL/UL=29:18 TDD for WiMAX. Mix of mobile and stationary users.

WCDMA Release 99, HSDPA increases capacity by almost a factor of three. Type 3 receivers that include MMSE equalization and Mobile Receive Diversity (MRxD) effectively double HSDPA spectral efficiency. The addition of dual-carrier operation and 64 QAM increases spectral efficiency by about 15%, and MIMO can increase spectral efficiency by another 15%, reaching 1.2 bps/Hz. Dual-carrier HSPA+ offers a gain in spectral efficiency from cross-carrier scheduling with possible gains of about 10%.<sup>79</sup>

Some enhancements, such as 64 QAM for HSPA, are simpler to deploy than other enhancements, such as 2X2 MIMO. The former can be done as a software upgrade, whereas the latter requires additional hardware at the base station. Thus, the figure does not necessarily show the actual progression of technologies that operators will deploy to increase spectral efficiency.

Beyond HSPA, 3GPP LTE results in further spectral efficiency gains, initially with 2X2 MIMO, then 4X2 MIMO, and then 4X4 MIMO. The gain for 4X2 MIMO will be 20% more than LTE with 2X2 MIMO; the gain for 4X4 MIMO in combination with interference rejection combining (IRC) will be 70% greater than 2X2 MIMO, reaching 2.4 bps/Hz. This value represents a practical deployment of 4X4 MIMO, with random phase and some timing-alignment error included in each of the four transmit paths. CoMP, discussed below in the appendix, provides a minimal contribution to spectral efficiency.

LTE is even more spectrally efficient with wider radio channels of 10+10 MHz and 20+20 MHz, although most of the gain is realized at 10+10 MHz. LTE TDD has spectral efficiency that is within 1% or 2% of LTE FDD.<sup>80</sup>

Figure 32 compares the uplink spectral efficiency of the different systems.

---

<sup>79</sup> 4G Americas member analysis. Vendor estimates for spectral-efficiency gains from dual-carrier operation range from 5% to 20%. Lower spectral efficiency gains are due to full-buffer traffic assumptions. In more realistic operating scenarios, gains will be significantly higher.

<sup>80</sup> Assumes best-effort traffic. Performance between LTE-TDD and FDD differs for real-time traffic for the following reasons: a.) The maximum number of HARQ process should be made as small as possible to reduce the packet re-transmission latency. b.) In FDD, the maximum number of HARQ process is fixed and, as such, the re-transmission latency is 7ms. c.) For TDD, the maximum number of HARQ process depends on the DL:UL configurations. As an example, the re-transmission latency for TDD config-1 is 9ms. d.) Because of higher re-transmission latency, the capacity of real-time services cannot be scaled for TDD from FDD based on the DL:UL ratio.

**Figure 32: Comparison of Uplink Spectral Efficiency<sup>81</sup>**

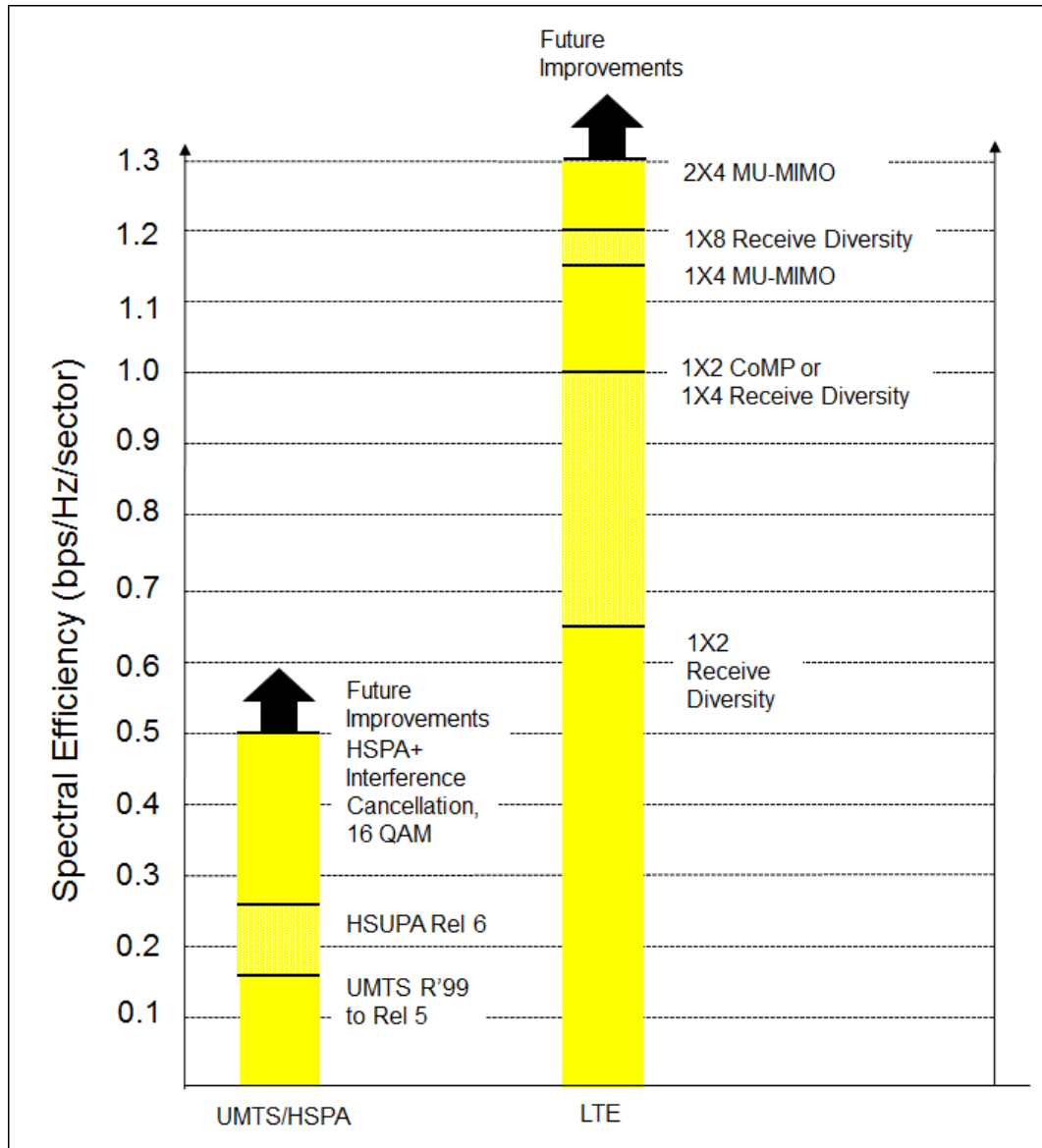

The implementation of HSUPA in HSPA significantly increases uplink capacity.

With LTE, spectral efficiency increases by use of receive diversity. Initial systems will employ 1X2 receive diversity (two antennas at the base station). 1X4 diversity will increase spectral efficiency by 50%, to 1.0 bps/Hz, and 1X8 diversity will provide a further 20% increase, from 1.0 bps/Hz to 1.2 bps/Hz.

It is also possible to employ Multi-User MIMO (MU-MIMO), which allows simultaneous transmission by multiple users on the same physical uplink resource to increase spectral

<sup>81</sup> Joint analysis by 4G Americas members. 5+5 MHz for UMTS-HSPA/LTE and CDMA2000, and 10 MHz DL/UL=29:18 TDD for WiMAX. Mix of mobile and stationary users.

efficiency. MU-MIMO will provide a 15% to 20% spectral efficiency gain, with actual increases depending on how well link adaptation is implemented. The figure uses a conservative 15% gain, showing MU-MIMO with a 1X4 antenna configuration increasing spectral efficiency by 15%, to 1.15 bps/Hz, and 2X4 MU-MIMO a further 15%, to 1.3 bps/Hz.

In Release 11, uplink CoMP using 1X2 will increase efficiency from .65 bps/Hz to 1.0 bps/Hz. Many of the techniques used to improve LTE spectral efficiency can also be applied to HSPA since they are independent of the radio interface.

Figure 33 compares voice spectral efficiency.

**Figure 33: Comparison of Voice Spectral Efficiency<sup>82</sup>**

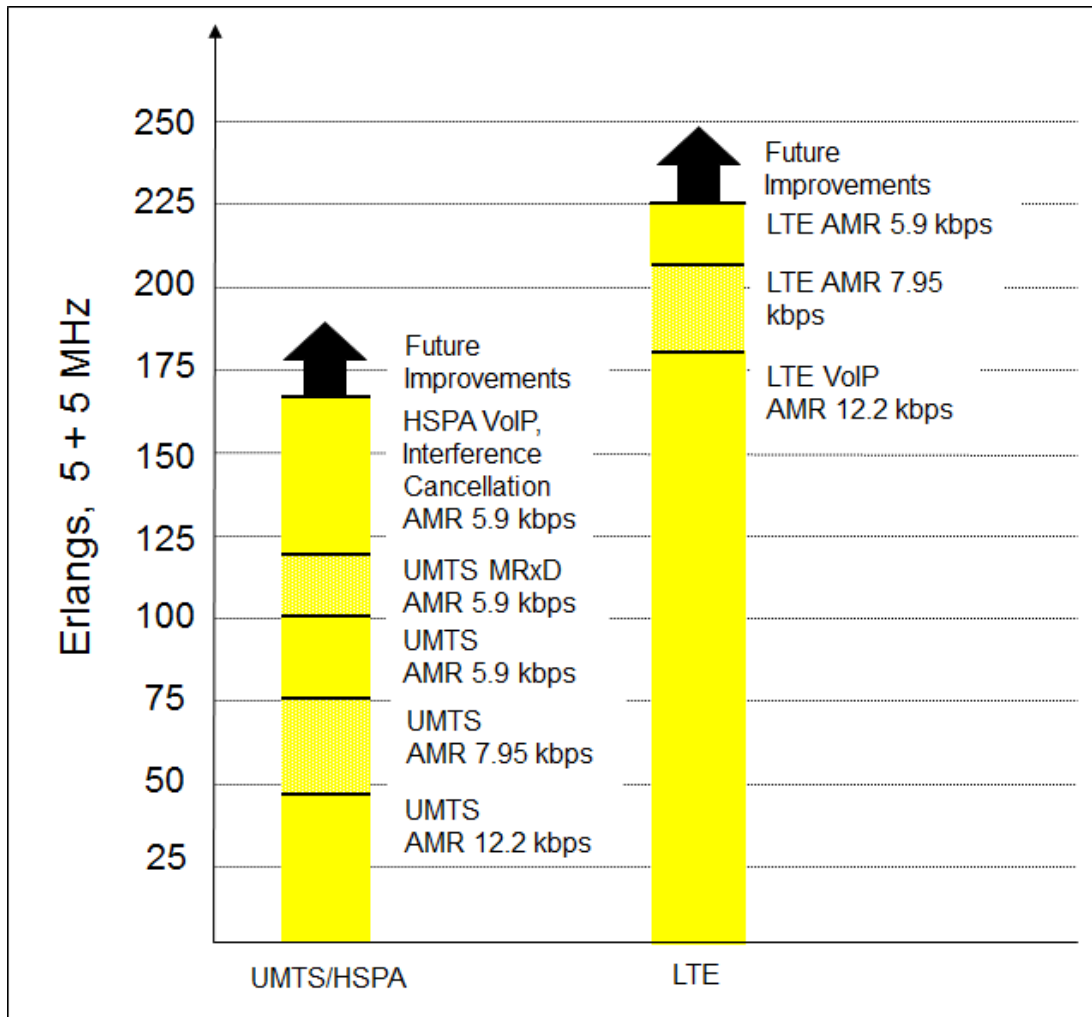

<sup>82</sup> Joint analysis by 4G Americas members. 5 + 5 MHz for UMTS-HSPA/LTE and CDMA2000, and 10 MHz TDD DL/UL=29:18 TDD for WiMAX. Mix of mobile and stationary users.

Figure 33 shows UMTS Release 99 with AMR 12.2 Kbps, 7.95 Kbps, and 5.9 Kbps vocoders. The AMR 12.2 Kbps vocoder provides superior voice quality in good (for example, static and indoor) channel conditions.

UMTS has dynamic adaptation between vocoder rates, enabling enhanced voice quality compared with EVRC at the expense of capacity in situations that are not capacity limited. With the addition of mobile receive diversity, UMTS circuit-switched voice capacity could reach 120 Erlangs in 5+5 MHz.

VoIP Erlangs in this paper are defined as the average number of concurrent VoIP users that can be supported over a defined period of time (often one hour) assuming a Poisson arrival process and meeting a specified outage criteria (often less than 2% of the users exhibiting greater than 1% frame-error rate). Depending on the specific enhancements implemented, voice capacity could double over existing circuit-switched systems. These gains do not derive through use of VoIP, but rather from advances in radio techniques applied to the data channels. Many of these same advances may also be applied to current circuit-switched modes.

LTE achieves very high voice spectral efficiency because of better uplink performance since there is no in-cell interference. The figure shows LTE VoIP spectral efficiency using AMR at 12.2 Kbps, 7.95 Kbps, and 5.9 Kbps.

VoIP for LTE can use a variety of codecs. The figures show performance assuming specific codecs at representative bit rates. For Enhanced Variable Rate Codecs (EVRCs), the figure shows the average bit rate.

The voice efficiency of the wideband AMR voice codec, operating at 12.65 Kbps, is similar to the AMR codec at 12.2 Kbps, with a value of 180 Erlangs for both since both codecs operate at approximately the same bit rate. 1xRTT has voice capacity of 85 Erlangs in 5+5 MHz with EVRC-A and reaches voice capacity of 120 Erlangs with the use of Quasi-Linear Interference Cancellation (QLIC) and EVRC-B at 6 Kbps.

CDMA2000 1X Advanced significantly increases voice capacity. With a subset of features, such as Reverse Link Interference Cancellation (RLIC) and receive diversity in devices, 1X Advanced achieves 175 Erlangs. With the addition of remaining features, including Advanced Quasi-Linear Interference Cancellation (QLIC), efficient power control, smart blanking, frame early termination, and ubiquitous penetration of supporting devices, theoretical capacity can reach 250 Erlangs.

## ***Data Consumed by Video***

Table 12 quantifies usage based on advanced video compression schemes such as H.264 and H.265, the type of application, and usage per day.

**Table 12: Data Consumed by Different Streaming Applications<sup>83</sup>**

Application	Throughput (Mbps)	MByte/hour	Hrs./day	GB/month
Audio or Music	0.1	58	0.5	0.9
			1.0	1.7
			2.0	3.5
			4.0	6.9
Small Screen Video (e.g., Feature Phone)	0.2	90	0.5	1.4
			1.0	2.7
			2.0	5.4
			4.0	10.8
Medium Screen Video (e.g., Smartphone, Tablet, Laptop)	1.0	450	0.5	6.8
			1.0	13.5
			2.0	27.0
			4.0	54.0
Larger Screen Video (e.g., 720p medium definition)	3.0	1350	0.5	20.3
			1.0	40.5
			2.0	81.0
			4.0	162.0
High Definition (e.g., 1080p Netflix HD)	5.0	2250	0.5	33.8
			1.0	67.5
			2.0	135.0
			4.0	270.0
Ultra High Definition (e.g., Netflix 4K)	15.0	6750	0.5	101.3
			1.0	202.5
			2.0	405.0
			4.0	810.0

**Video applications: telemedicine, education, social networking, entertainment.**

## **CDMA2000**

Although GSM/HSPA/LTE networks are dominating global cellular-technology deployments, operators deployed other wireless technologies to serve both wide and local areas, including CDMA2000 and WiMAX.

CDMA2000, consisting principally of One Carrier Radio Transmission Technology (1xRTT) and One Carrier-Evolved, Data-Optimized (1xEV-DO) versions, is the other major cellular technology deployed in many parts of the world. 1xRTT is currently the most widely deployed CDMA2000 version. In June 2014, 112 EV-DO Rel. 0 networks, 175 EV-DO Rev.

<sup>83</sup> Rysavy Research analysis.

A networks, and 12 EV-DO Rev. B networks were deployed worldwide.<sup>84</sup> Most CDMA2000 operators have chosen LTE as their 4G solution.

Current networks use either Rel. 0, Rev. A, or Rev. B radio-interface specifications. EV-DO Rev. A incorporates a more efficient uplink, which has spectral efficiency similar to that of HSPA. Operators started to make EV-DO Rev. A commercially available in 2007 and EV-DO Rev. B available in 2010.

EV-DO uses many of the same techniques for optimizing spectral efficiency as HSPA, including higher-order modulation, efficient scheduling, turbo-coding, and adaptive modulation and coding. For these reasons, it achieves spectral efficiency that is virtually the same as HSPA. The 1x technologies operate in the 1.25 MHz radio channels compared with the 5 MHz channels UMTS uses, resulting in lower theoretical peak rates, although average throughputs for high-level network loading are similar. Under low- to medium-load conditions, because of the lower peak achievable data rates, EV-DO or EV-DO Rev. A achieves a lower typical performance level than HSPA. One U.S. operator has quoted 400 to 700 kilobits per second (Kbps) average downlink throughput for EV-DO Rev. 0 and between 600 Kbps and 1.4 Mbps for EV-DO Rev. A.<sup>85</sup>

Although in the past it was impossible to have simultaneous voice and data sessions with 1X voice and EV-DO data, this is now feasible via a capability called Simultaneous 1X Voice and EV-DO Data (SVDO), available in some new handset chipsets.<sup>86</sup> Similarly, devices can simultaneously have 1X voice and LTE data sessions using a capability called Simultaneous Voice and LTE (SVLTE).

3GPP2 has also defined EV-DO Rev. B, which can combine up to 15 1.25 MHz radio channels in 20 MHz, significantly boosting peak theoretical rates to 73.5 Mbps. More likely, an operator would combine three radio channels in 5 MHz. Such an approach, by itself, does not necessarily increase overall capacity, but it does offer users higher peak-data rates.

Beyond EV-DO Rev. B, 3GPP2 in 2010 finalized the specifications for EV-DO Rev. C, although the industry tends to use the term "DO Advanced" for features beyond Rev. B. One feature of DO Advanced is network load balancing that connects mobile devices to less loaded sectors even if the signal is weaker.

1X Advanced will significantly increase voice capacity over CDMA2000 1xRTT. CDMA operators are not only considering 1X Advanced to increase voice capacity, but also to free up spectrum to support more data services via additional EV-DO radio carriers or LTE.

3GPP2 has defined technical means to integrate CDMA2000 networks with LTE along two available approaches:

---

<sup>84</sup> CDMA Developer Group, home page, <http://www.cdg.org>, accessed June 20, 2014.

<sup>85</sup> Sprint, "Sprint 3G network," [http://shop2.sprint.com/en/coverage/support/mobile\\_broadband\\_network\\_popup.shtml](http://shop2.sprint.com/en/coverage/support/mobile_broadband_network_popup.shtml), accessed June 20, 2014.

<sup>86</sup> 4G Americas member company.

1. **Loose coupling.** This involves little or no intersystem functionality, and resources are released in the source system prior to handover execution.
2. **Tight coupling.** The two systems intercommunicate with network-controlled make-before-break handovers. Tight coupling allows maintenance of data sessions with the same IP address. This will likely involve a more complex implementation than loose coupling.

## **WiMAX**

WiMAX was developed as a potential alternative to cellular technology for wide-area wireless networks. Based on OFDMA and accepted by the ITU as an IMT-2000 (3G technology) under the name "OFDMA TDD Wireless Metropolitan Area Network" (WMAN), WiMAX tried to challenge existing wireless technologies by promising greater capabilities and efficiencies than alternative approaches. But as WiMAX, particularly mobile WiMAX, was deployed, vendors continued to enhance HSPA, and operators accelerated their LTE deployments. Consequently, WiMAX advantages were no longer perceived as compelling.

WiMAX has gained the greatest traction in developing countries as an alternative to wireline deployment. In the United States, Clearwire, Sprint Nextel, and others (Intel, Google, Comcast, Time Warner Cable, and Bright House Networks) created a joint venture to deploy a nationwide WiMAX network. Clearwire, now fully owned by Sprint, has started deploying TDD-LTE and will shut down its WiMAX network by the end of 2015.<sup>87</sup>

The original specification, IEEE 802.16, was completed in 2001 and was intended primarily for telecom backhaul applications in point-to-point, line-of-sight configurations using spectrum above 10 GHz. IEEE 802.16 uses a radio interface based on a single-carrier waveform.

The next major step in the evolution of IEEE 802.16 occurred in 2004 with the release of the IEEE 802.16-2004 standard. It added multiple radio interfaces, including one based on OFDM-256 and one based on OFDMA. IEEE 802.16-2004 also supports point-to-multipoint communications, sub-10 GHz operation, and non-line-of-sight communications. Like the original version of the standard, operation is fixed, meaning that subscriber stations are typically immobile. Potential applications include wireless Internet service provider (ISP) service and local telephony bypass (as an alternative to cable modem or DSL service). Vendors can design equipment for either licensed or unlicensed bands.

IEEE 802.16e-2005, and then IEEE 802.16-2009, added mobility capabilities including support for radio operation while mobile, handovers across base stations, and handovers across operators. Unlike IEEE 802.16-2004, which operates in both licensed and unlicensed bands, IEEE 802.16e-2005 (referred to as mobile WiMAX) uses licensed bands. Current WiMAX profiles emphasize TDD operation. Mobile WiMAX networks are not backward-compatible with IEEE 802.16-2004 networks.

---

<sup>87</sup> Fierce Wireless, "Sprint to shutter WiMAX network by end of 2015, will turn off at least 6,000 towers," <http://www.fiercewireless.com/story/sprint-shutter-wimax-network-end-2015-will-turn-least-6000-clearwire-sites/2014-04-07>, accessed May 12, 2014.



Current mobile WiMAX networks use 2X2 MIMO or 4X2 MIMO, TDD, and 10 MHz radio channels in a profile defined by the WiMAX Forum, known as WiMAX Wave 2 or, more formally, WiMAX System Profile 1.0. Beyond Release 1.0, the WiMAX Forum defined a profile called WiMAX Release 1.5. This profile includes various refinements intended to improve efficiency and performance and could be available for deployment in a similar timeframe as LTE.

A subsequent version, Mobile WiMAX 2.0, was designed to address the performance requirements of ITU IMT-Advanced Project and is standardized in a new IEEE standard, IEEE 802.16m. It is uncertain whether 802.16m will ever be commercialized.

WiMAX momentum has stalled as LTE becomes the global mobile broadband standard.

## ***Spectrum Bands***

3GPP technologies operate in a wide range of radio bands. As new spectrum becomes available, 3GPP updates its specifications for these bands. Although the support of a new frequency band may be introduced in a particular release, 3GPP specifies ways to implement devices and infrastructure operating on any frequency band, according to releases previous to the introduction of that particular frequency band. For example, although band 5 (US Cellular Band) was introduced in Release 6, the first devices operating on this band were compliant with the release 5 of the standard.

Table 13 shows the UMTS FDD bands.

**Table 13: UMTS FDD Bands<sup>88</sup>**

Operating Band	UL Frequencies UE transmit, Node B receive	DL frequencies UE receive, Node B transmit
I	1920 - 1980 MHz	2110 -2170 MHz
II	1850 -1910 MHz	1930 -1990 MHz
III	1710-1785 MHz	1805-1880 MHz
IV	1710-1755 MHz	2110-2155 MHz
V	824 - 849MHz	869-894MHz
VI	830-840 MHz	875-885 MHz
VII	2500 - 2570 MHz	2620 - 2690 MHz
VIII	880 - 915 MHz	925 - 960 MHz
IX	1749.9 - 1784.9 MHz	1844.9 - 1879.9 MHz
X	1710-1770 MHz	2110-2170 MHz
XI	1427.9 - 1447.9 MHz	1475.9 - 1495.9 MHz
XII	699 - 716 MHz	729 - 746 MHz
XIII	777 - 787 MHz	746 - 756 MHz
XIV	788 - 798 MHz	758 - 768 MHz
XV	Reserved	Reserved
XVI	Reserved	Reserved
XVII	Reserved	Reserved
XVIII	Reserved	Reserved
XIX	830 – 845 MHz	875 -890 MHz
XX	832 - 862 MHz	791 - 821 MHz
XXI	1447.9 - 1462.9 MHz	1495.9 - 1510.9 MHz
XXII	3410 – 3490 MHz	3510 – 3590 MHz
XXV	1850 -1915 MHz	1930 -1995 MHz
XXVI	814-849 MHz	859-894 MHz
XXXII (NOTE 1)	N/A	1452 – 1496 MHz
NOTE 1: Restricted to UTRA operation when dual band is configured (e.g., DB-DC-HSDPA or dual-band 4C-HSDPA). The downlink frequenc(ies) of this band are paired with the uplink frequenc(ies) of the other FDD band (external) of the dual band configuration.		

Universal Mobile Telecommunications System (UMTS) Time Division Duplex (TDD) bands are the same as the LTE TDD bands.

Table 14 details the LTE Frequency Division Duplex (FDD) and TDD bands.

---

<sup>88</sup> 3GPP, *Base Station (BS) radio transmission and reception (FDD) (Release 12)*, December 2014, Technical Specification 25.104, V12.5.0.

**Table 14: LTE FDD and TDD bands<sup>89</sup>**

E-UTRA Operating Band	Uplink (UL) operating band BS receive UE transmit		Downlink (DL) operating band BS transmit UE receive		Duplex Mode
	F <sub>UL,low</sub>	F <sub>UL,high</sub>	F <sub>DL,low</sub>	F <sub>DL,high</sub>	
1	1920 MHz	1980 MHz	2110 MHz	2170 MHz	FDD
2	1850 MHz	1910 MHz	1930 MHz	1990 MHz	FDD
3	1710 MHz	1785 MHz	1805 MHz	1880 MHz	FDD
4	1710 MHz	1755 MHz	2110 MHz	2155 MHz	FDD
5	824 MHz	849 MHz	869 MHz	894 MHz	FDD
6 (NOTE 1)	830 MHz	840 MHz	875 MHz	885 MHz	FDD
7	2500 MHz	2570 MHz	2620 MHz	2690 MHz	FDD
8	880 MHz	915 MHz	925 MHz	960 MHz	FDD
9	1749.9 MHz	1784.9 MHz	1844.9 MHz	1879.9 MHz	FDD
10	1710 MHz	1770 MHz	2110 MHz	2170 MHz	FDD
11	1427.9 MHz	1447.9 MHz	1475.9 MHz	1495.9 MHz	FDD
12	699 MHz	716 MHz	729 MHz	746 MHz	FDD
13	777 MHz	787 MHz	746 MHz	756 MHz	FDD
14	788 MHz	798 MHz	758 MHz	768 MHz	FDD
15	Reserved		Reserved		FDD
16	Reserved		Reserved		FDD
17	704 MHz	716 MHz	734 MHz	746 MHz	FDD
18	815 MHz	830 MHz	860 MHz	875 MHz	FDD
19	830 MHz	845 MHz	875 MHz	890 MHz	FDD
20	832 MHz	862 MHz	791 MHz	821 MHz	FDD
21	1447.9 MHz	1462.9 MHz	1495.9 MHz	1510.9 MHz	FDD
22	3410 MHz	3490 MHz	3510 MHz	3590 MHz	FDD
23	2000 MHz	2020 MHz	2180 MHz	2200 MHz	FDD
24	1626.5 MHz	1660.5 MHz	1525 MHz	1559 MHz	FDD
25	1850 MHz	1915 MHz	1930 MHz	1995 MHz	FDD
26	814 MHz	849 MHz	859 MHz	894 MHz	FDD
27	807 MHz	824 MHz	852 MHz	869 MHz	FDD
28	703 MHz	748 MHz	758 MHz	803 MHz	FDD
29	N/A		717 MHz	728 MHz	FDD (NOTE 2)
30	2305 MHz	2315 MHz	2350 MHz	2360 MHz	FDD
31	452.5 MHz	457.5 MHz	462.5 MHz	467.5 MHz	FDD
32	N/A		1452 MHz	1496 MHz	FDD (NOTE 2)
33	1900 MHz	1920 MHz	1900 MHz	1920 MHz	TDD
34	2010 MHz	2025 MHz	2010 MHz	2025 MHz	TDD
35	1850 MHz	1910 MHz	1850 MHz	1910 MHz	TDD
36	1930 MHz	1990 MHz	1930 MHz	1990 MHz	TDD
37	1910 MHz	1930 MHz	1910 MHz	1930 MHz	TDD
38	2570 MHz	2620 MHz	2570 MHz	2620 MHz	TDD
39	1880 MHz	1920 MHz	1880 MHz	1920 MHz	TDD
40	2300 MHz	2400 MHz	2300 MHz	2400 MHz	TDD
41	2496 MHz	2690 MHz	2496 MHz	2690 MHz	TDD
42	3400 MHz	3600 MHz	3400 MHz	3600 MHz	TDD
43	3600 MHz	3800 MHz	3600 MHz	3800 MHz	TDD
44	703 MHz	803 MHz	703 MHz	803 MHz	TDD

NOTE 1: Band 6 is not applicable.  
 NOTE 2: Restricted to E-UTRA operation when carrier aggregation is configured. The downlink operating band is paired with the uplink operating band (external) of the carrier aggregation configuration that is supporting the configured Pcell.

<sup>89</sup> 3GPP, *Evolved Universal Terrestrial Radio Access (E-UTRA); Base Station (BS) radio transmission and reception (Release 12)*, March 2015, Technical Specification 36.104, V12.7.0.

## UMTS-HSPA

UMTS technology is mature and benefits from research and development that began in the early 1990s. It has been thoroughly trialed, tested, and commercially deployed. UMTS employs a wideband CDMA radio-access technology. The primary benefits of UMTS include high spectral efficiency for voice and data, simultaneous voice and data capability, high user densities that can be supported with low infrastructure costs, and support for high-bandwidth data applications. Operators can also use their entire available spectrum for both voice and high-speed data services.

Additionally, operators can use a common core network, called the UMTS multi-radio network as shown in Figure 34, which supports multiple radio-access networks including GSM, EDGE, WCDMA, HSPA, and evolutions of these technologies.

**Figure 34: UMTS Multi-radio Network**

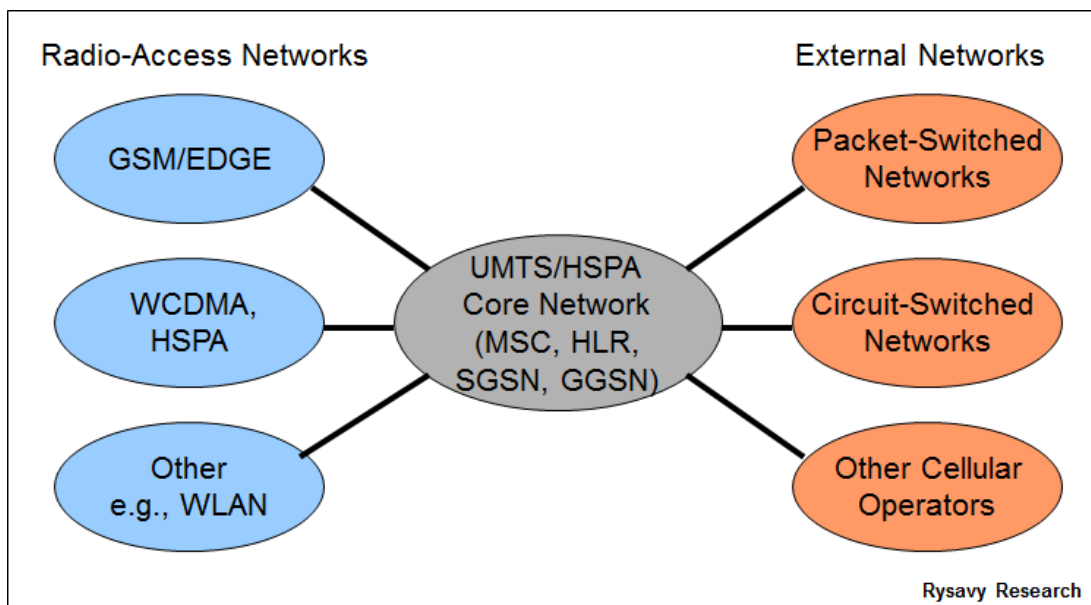

HSPA refers to networks that support both HSDPA and HSUPA. All new deployments today are HSPA, and many operators have upgraded their HSDPA networks to HSPA. For example, in 2008, AT&T upgraded most of its network to HSPA. By the end of 2008, HSPA was deployed throughout the Americas.

The UMTS radio-access network consists of base stations referred to as Node B (corresponding to GSM base transceiver systems) that connect to RNCs (corresponding to GSM base station controllers [BSCs]). The RNCs connect to the core network as do the BSCs. When both GSM and WCDMA access networks are available, the network can hand users over between these networks. This is important for managing capacity, as well as in areas in which the operator has continuous GSM coverage, but has only deployed WCDMA in some locations.

Whereas GSM can effectively operate like a spread-spectrum system<sup>90</sup>, based on time division in combination with frequency hopping, WCDMA is a direct-sequence, spread-

<sup>90</sup> Spread spectrum systems can either be direct sequence or frequency hopping.

spectrum system. WCDMA is spectrally more efficient than GSM, but it is the wideband nature of WCDMA that provides its greatest advantage—the ability to translate the available spectrum into high data rates. This wideband technology approach results in the flexibility to manage multiple traffic types including voice, narrowband data, and wideband data.

## HSDPA

HSDPA, specified in 3GPP Release 5, saw the introduction of high-performance, packet-data service that delivers peak theoretical rates of 14 Mbps. Peak user-achievable throughput rates in initial deployments are well over 1 Mbps and as high as 4 Mbps in some networks. The same radio carrier can simultaneously service UMTS voice and data users, as well as HSDPA data users.

HSDPA achieves its high speeds through techniques similar to those that push EDGE performance past GPRS including higher order modulation, variable coding, and soft combining, as well as through the addition of fast scheduling and other techniques.

HSDPA achieves its performance gains from the following radio features:

- ❑ High-speed channels shared in both code and time domains
- ❑ Short TTI
- ❑ Fast scheduling and user diversity
- ❑ Higher order modulation
- ❑ Fast link adaptation
- ❑ Fast HARQ

These features function as follows:

**High-Speed Shared Channels and Short Transmission Time Interval:** First, HSDPA uses high-speed data channels called High Speed Physical Downlink Shared Channels (HS-PDSCH). Up to 15 of these channels can operate in the 5 MHz WCDMA radio channel. Each uses a fixed spreading factor of 16. User transmissions are assigned to one or more of these channels for a short TTI of 2 msec. The network can then readjust how users are assigned to different HS-PDSCH every 2 msec. Resources are thus assigned in both time (the TTI interval) and code domains (the HS-PDSCH channels). Figure 35 illustrates different users obtaining different radio resources.

**Figure 35: High Speed–Downlink Shared Channels (Example)**

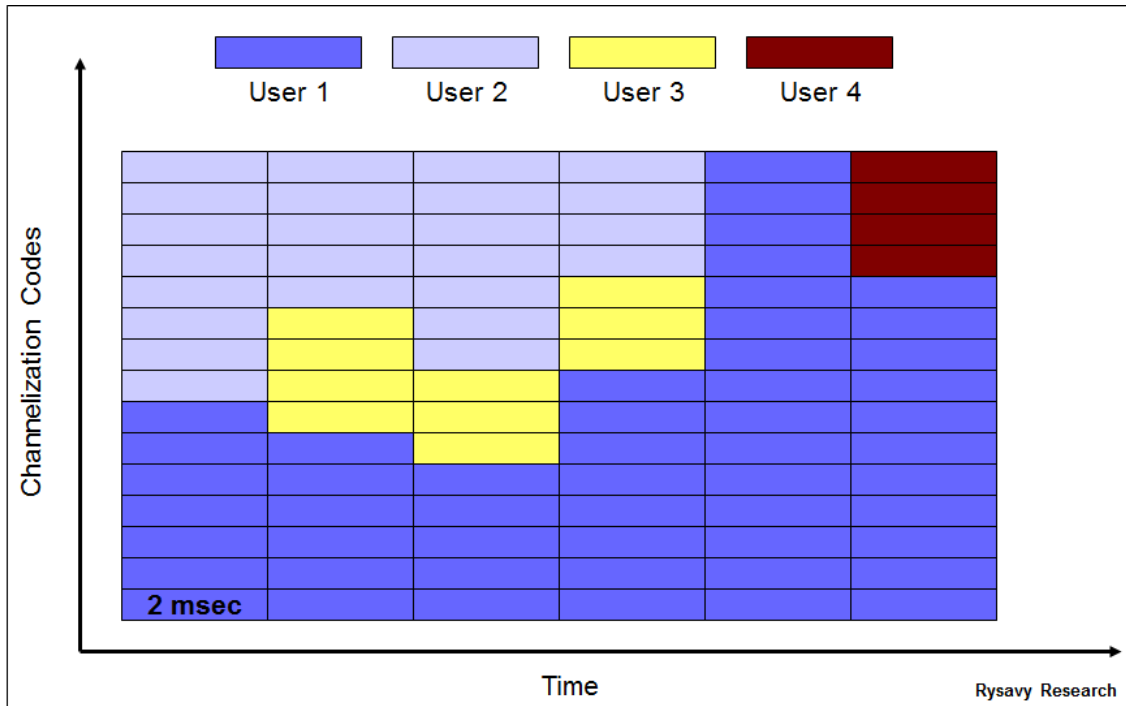

**Fast Scheduling and User Diversity:** Fast scheduling exploits the short TTI by assigning users channels that have the best instantaneous channel conditions, rather than in a round-robin fashion. Because channel conditions vary somewhat randomly across users, most users can be serviced with optimum radio conditions and thereby obtain optimum data throughput. Figure 36 shows how a scheduler might choose between two users based on their varying radio conditions to emphasize the user with better instantaneous signal quality. With about 30 users active in a sector, the network achieves significant user diversity and much higher spectral efficiency. The system also ensures that each user receives a minimum level of throughput, an approach called proportional fair scheduling.

**Figure 36: User Diversity**

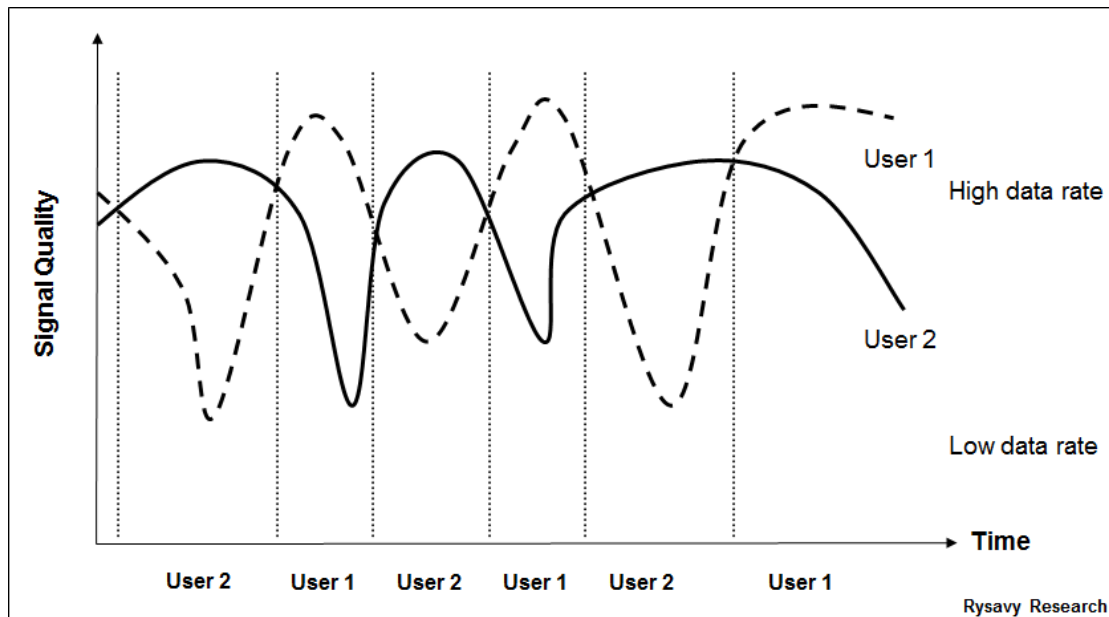

**Higher Order Modulation:** HSDPA uses both the modulation used in WCDMA—namely QPSK—and, under good radio conditions, an advanced modulation scheme—16 QAM. 16 QAM transmits 4 bits of data in each radio symbol compared to 2 bits with QPSK. Data throughput is increased with 16 QAM, while QPSK is available for adverse radio conditions. HSPA Evolution adds 64 QAM modulation to further increase throughput rates. 64 QAM became available in Release 7, and the combination of MIMO and 64 QAM became available in Release 8.

**Fast Link Adaptation:** Depending on the condition of the radio channel, different levels of forward-error correction (channel coding) can also be employed. For example, a three-quarter coding rate means that three quarters of the bits transmitted are user bits, and one quarter are error-correcting bits. Fast link adaptation refers to the process of selecting and quickly updating the optimum modulation and coding rate and occurs in coordination with fast scheduling.

**Fast Hybrid Automatic Repeat Request:** Another HSDPA technique is Fast Hybrid Automatic Repeat Request (Fast Hybrid ARQ). “Fast” refers to the medium-access control mechanisms implemented in Node B (along with scheduling and link adaptation), as opposed to the BSC in GPRS/EDGE, and “hybrid” refers to a process of combining repeated data transmissions with prior transmissions to increase the likelihood of successful decoding. Managing and responding to real-time radio variations at the base station, as opposed to an internal network node, reduces delays and further improves overall data throughput.

Using the approaches just described, HSDPA maximizes data throughputs and capacity and minimizes delays. For users, this translates to better network performance under loaded conditions, faster application performance, and a greater range of applications that function well.

Field results validate the theoretical throughput results. With initial 1.8 Mbps peak-rate devices, vendors measured consistent throughput rates in actual deployments of more than 1 Mbps. These rates rose to more than 2 Mbps for 3.6 Mbps devices and then close to 4 Mbps for 7.2 Mbps devices.

In 2008, typical devices supporting peak data rates of 3.6 Mbps or 7.2 Mbps became available. Many operator networks support 7.2 Mbps peak operation, and some even support the maximum rate of 14.4 Mbps.

## **HSUPA**

Whereas HSDPA optimizes downlink performance, HSUPA—which uses the Enhanced Dedicated Channel (E-DCH)—constitutes a set of improvements that optimizes uplink performance. Networks and devices supporting HSUPA became available in 2007. These improvements include higher throughputs, reduced latency, and increased spectral efficiency. HSUPA was standardized in Release 6. It results in an approximately 85% increase in overall cell throughput on the uplink and more than a 50% gain in user throughput. HSUPA also reduces packet delays, a significant benefit resulting in much improved application performance on HSPA networks

Although the primary downlink traffic channel supporting HSDPA serves as a shared channel designed for the support of services delivered through the packet-switched domain, the primary uplink traffic channel defined for HSUPA is a dedicated channel that could be used for services delivered through either the circuit-switched or the packet-switched domains. Nevertheless, by extension and for simplicity, the WCDMA-enhanced uplink capabilities are often identified in the literature as HSUPA.

HSUPA achieves its performance gains through the following approaches:

- ❑ An enhanced dedicated physical channel.
- ❑ A short TTI, as low as 2 msec, which allows faster responses to changing radio conditions and error conditions.
- ❑ Fast Node B-based scheduling, which allows the base station to efficiently allocate radio resources.
- ❑ Fast Hybrid ARQ, which improves the efficiency of error processing.

The combination of TTI, fast scheduling, and Fast Hybrid ARQ also serves to reduce latency. HSUPA can operate with or without HSDPA in the downlink, although use the two approaches together. The improved uplink mechanisms also translate to better coverage and, for rural deployments, larger cell sizes.

HSUPA can achieve different throughput rates based on various parameters including the number of codes used, the spreading factor of the codes, the TTI value, and the transport block size in bytes.

Initial devices enabled peak user rates of close to 2 Mbps as measured in actual network deployments, while current devices have throughputs of more than 5 Mbps. Future devices could have network rates as high as 69 Mbps, as discussed further below.

Beyond throughput enhancements, HSUPA also significantly reduces latency.



## ***Evolution of HSPA (HSPA+)***

The goal in evolving HSPA is to exploit available radio technologies—largely enabled by increases in digital signal processing power—to maximize CDMA-based radio performance. This evolution has significantly advanced HSPA and extends the life of sizeable operator infrastructure investments.

Wireless and networking technologists have defined a series of enhancements for HSPA, beginning in Release 7 and now continuing through Release 12. These include advanced receivers, multi-carrier operation, MIMO, Continuous Packet Connectivity, Higher-Order Modulation, One Tunnel Architecture, HetNet support, and advanced voice capabilities both in circuit- and packet-switched domains.

Taking advantage of these various radio technologies, 3GPP has standardized a number of features, beginning in Release 7 including higher order modulation and MIMO. Collectively, these capabilities are referred to as HSPA+. Release 8 through Release 12 include further enhancements.

The goals of HSPA+ were to:

- ❑ Exploit the full potential of a CDMA approach.
- ❑ Provide smooth interworking between HSPA+ and LTE, thereby facilitating the operation of both technologies. As such, operators may choose to leverage the EPC planned for LTE.
- ❑ Allow operation in a packet-only mode for both voice and data.
- ❑ Be backward-compatible with previous systems while incurring no performance degradation with either earlier or newer devices.
- ❑ Facilitate migration from current HSPA infrastructure to HSPA+ infrastructure.

### **Advanced Receivers**

3GPP has specified a number advanced-received designs including: Type 1, which uses mobile-receive diversity; Type 2, which uses channel equalization; and Type 3, which includes a combination of receive diversity and channel equalization. Type 3i devices, which became available in 2012, employ interference cancellation. Note that the different types of receivers are release-independent. For example, Type 3i receivers will work and provide a capacity gain in an earlier Release 5 network.

The first approach is mobile-receive diversity. This technique relies on the optimal combination of received signals from separate receiving antennas. The antenna spacing yields signals that have somewhat independent fading characteristics. Hence, the combined signal can be more effectively decoded, which almost doubles downlink capacity when done in combination with channel equalization. Receive diversity is effective even with smaller devices such as like PC Card modems and smartphones.

Current receiver architectures based on rake receivers are effective for speeds up to a few megabits per second. But at higher speeds, the combination of reduced symbol period and multipath interference results in inter-symbol interference and diminishes rake receiver performance. This problem can be solved by advanced-receiver architectures with channel equalizers that yield additional capacity gains over HSDPA with receive diversity. Alternate advanced-receiver approaches include interference cancellation and

generalized rake receivers (G-Rake). Different vendors are emphasizing different approaches. The performance requirements for advanced-receiver architectures, however, were specified in 3GPP Release 6. The combination of mobile-receive diversity and channel equalization (Type 3) is especially attractive, because it results in a large capacity gain independent of the radio channel.

What makes such enhancements attractive is that the networks do not require any changes other than increased capacity within the infrastructure to support the higher bandwidth. Moreover, the network can support a combination of devices including both earlier devices that do not include these enhancements and later devices that do. Device vendors can selectively apply these enhancements to their higher-end devices.

## MIMO

Another standardized capability is MIMO, a technique that employs multiple transmit antennas and multiple receive antennas, often in combination with multiple radios and multiple parallel data streams. The most common use of the term “MIMO” applies to spatial multiplexing. The transmitter sends different data streams over each antenna. Whereas multipath is an impediment for other radio systems, MIMO—as illustrated in Figure 37—actually exploits multipath, relying on signals to travel across different uncorrelated communications paths. The multiple data paths effectively operate in parallel and, with appropriate decoding, in a multiplicative gain in throughput.

**Figure 37: MIMO Using Multiple Paths to Boost Throughput and Capacity**

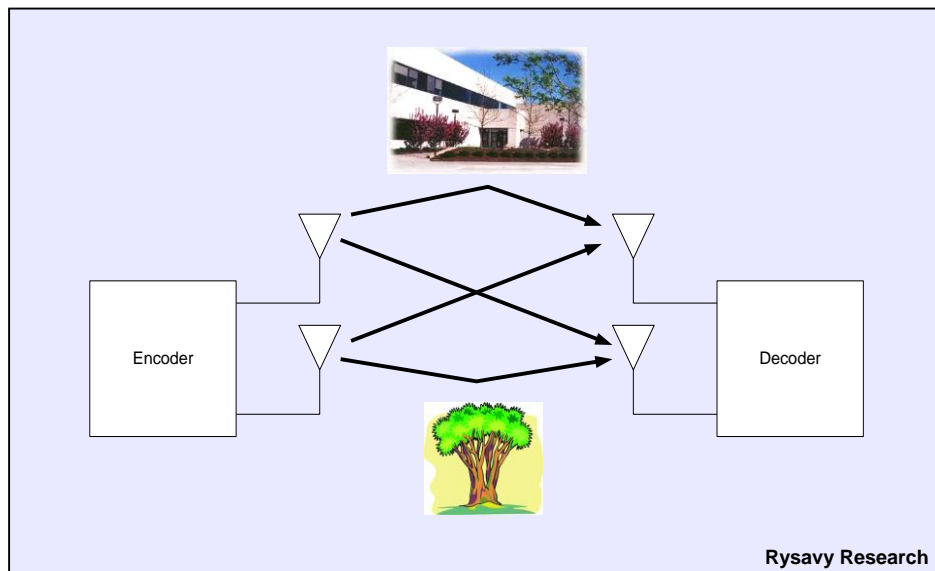

Tests of MIMO have proven effective in WLANs operating in relative isolation where interference is not a dominant factor. Spatial multiplexing MIMO can also benefit HSPA “hotspots” serving local areas including airports, campuses, and malls. In a fully loaded network with interference from adjacent cells, however, overall capacity gains will be more modest—in the range of 20% to 33% over mobile-receive diversity. Relative to a 1x1 antenna system, however, 2X2 MIMO can deliver cell throughput gains of about 80%. 3GPP has standardized spatial multiplexing MIMO in Release 7 using Double Transmit Adaptive Array (D-TxAA).

Release 9 provides for a means to leverage MIMO antennas at the base station when transmitting to user equipment that does not support MIMO. The two transmit antennas in the base station can transmit a single stream using beam forming. This is called "single-stream MIMO" or "MIMO with single-stream restriction" and results in higher throughput rates because of the improved signal received by the user equipment.

3GPP designed uplink dual-antenna beamforming and 2X2 MIMO for HSPA+ in Release 11.

### Continuous Packet Connectivity

Continuous Packet Connectivity (CPC) specified in Release 7 reduces the uplink interference created by the dedicated physical control channels of packet data users when those channels have no user data to transmit, which increases the number of simultaneously connected HSUPA users. CPC allows both discontinuous uplink transmission and discontinuous downlink reception, wherein the modem can turn off its receiver after a certain period of HSDPA inactivity. CPC is especially beneficial to VoIP on the uplink because the radio can turn off between VoIP packets, as shown in Figure 38.

**Figure 38: Continuous Packet Connectivity**

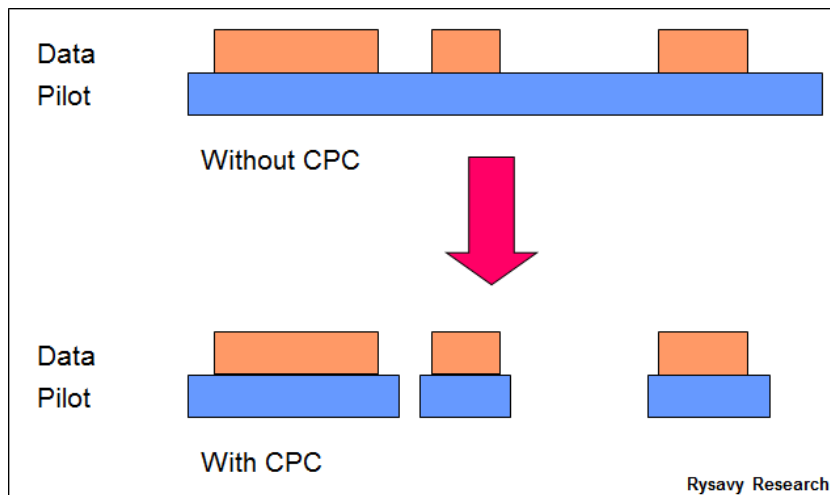

### Higher Order Modulation

Another way of increasing performance is with higher order modulation. HSPA uses 16 QAM on the downlink and QPSK on the uplink, but HSPA+ adds 64 QAM to the downlink and 16 QAM to the uplink. 3GPP has also introduced 64 QAM to the uplink for HSPA+ in Release 11. Higher order modulation requires a better SNR, achieved through receive diversity and equalization.

### Multi-Carrier HSPA

3GPP defined dual-carrier HSPA operation in Release 8, which coordinates the operation of HSPA on two adjacent 5 MHz carriers so that data transmissions can achieve higher throughput rates, as shown in Figure 39. The work item assumed two adjacent carriers, downlink operation and no MIMO. This configuration achieves a doubling of the 21 Mbps maximum rate available on each channel to 42 Mbps.

**Figure 39: Dual-Carrier Operation with One Uplink Carrier<sup>91</sup>**

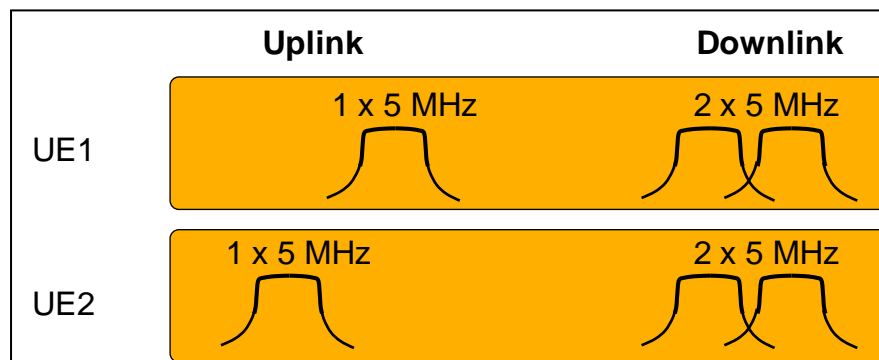

Benefits include:

- ❑ An increase in spectral efficiency of about 15%, comparable to what can be obtained with 2X2 MIMO.
- ❑ Significantly higher peak throughputs available to users, especially in lightly-loaded networks.
- ❑ Same maximum-throughput rate of 42 Mbps as using MIMO, but with a less expensive infrastructure upgrade.

Scheduling packets across two carriers is a more efficient use of resources, resulting in what is called trunking gain. Multi-user diversity also improves from an increased number of users across the two channels.

Release 9 also supports dual-carrier operation in the uplink. Release 10 specifies the use of up to four channels, resulting in peak downlink data rates of 168 Mbps. Release 11 supports eight radio channels on the downlink, resulting in a further doubling of theoretical throughput to 336 Mbps. On the uplink, devices can transmit using two antennas for either rank 1 (single stream beamforming) or rank 2 (dual-stream MIMO) transmission modes. Rank 1 beamforming helps with coverage (approximately 40%), while rank 2 MIMO helps with throughput speeds (approximately 20% median and 80% at cell edge). In addition, 64 QAM will be possible on the uplink, enabling uplink speeds to 69 Mbps in dual-carrier operation.

### **Downlink Multiflow Transmission**

Release 11 specifies means by which two cells can transmit to the mobile station at the same time. The two cells transmit independent data, in effect a spatial multiplexing approach, improving both peak and average data.

Multiflow transmission with HSPA+ also enhances HetNet operation in which picocell coverage can be expanded within a macrocell coverage area, as shown in Figure 40.

---

<sup>91</sup> Harri Holma and Antti Toskala, *LTE for UMTS, OFDMA and SC-FDMA Based Radio Access*, Wiley, April 2009.

**Figure 40: HSPA+ HetNet Using Multipoint Transmission<sup>92</sup>**

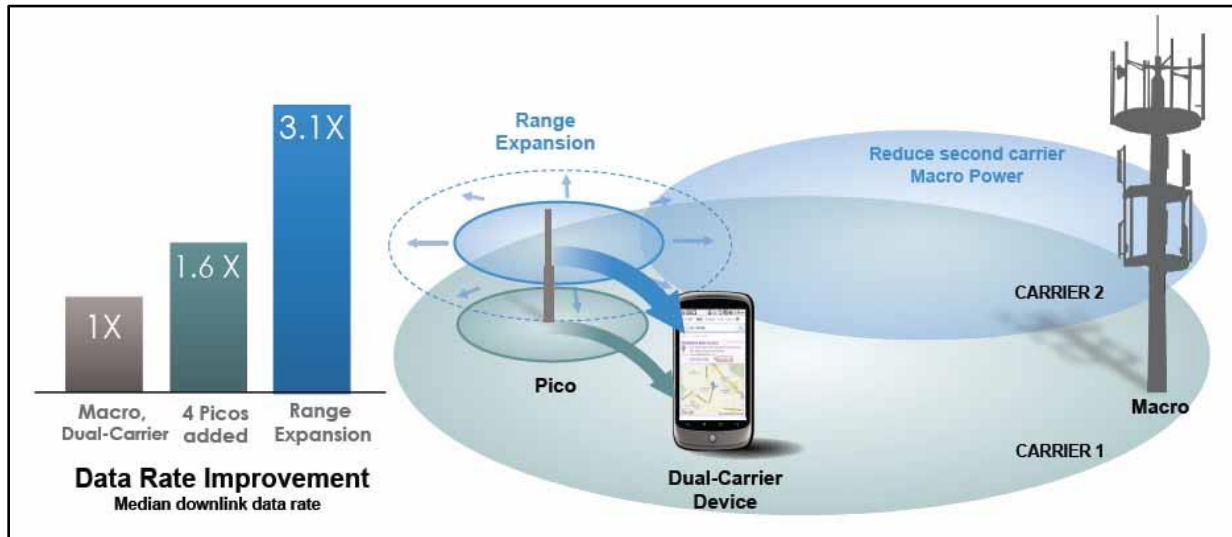

Multiflow enhances HSPA+ network operation using the following approaches:

- ❑ **Single Frequency Dual Cell.** The UE communicates with two different cells using the same frequency, improving cell-edge performance and providing network load balancing.
- ❑ **Dual Frequency Three Cell.** The UE communicates with two different cells using the same frequency. In addition, it communicates with one other cell on a different frequency.
- ❑ **Dual Frequency Four Cells.** The UE communicates using two instances of Single Frequency Dual Cell operation as described above.

In Release 12, 3GPP is considering the following enhancement to Multiflow operation, which is primarily targeted towards HetNet operation:

- ❑ **Dual Frequency Dual Carrier.** The UE aggregates cells on two different frequencies from two different sites.

## HSPA+ Throughput Rates

Table 15 summarizes the capabilities of HSPA and HSPA+ based on the various methods discussed above.

<sup>92</sup> Qualcomm, "HSPA+ Advanced: Taking HSPA+ to the Next Level," February 2012, <http://www.qualcomm.com/media/documents/hspa-advanced-taking-hspa-next-level-whitepaper>, accessed June 20, 2014.

**Table 15: HSPA Throughput Evolution**

<b>Technology</b>	<b>Downlink (Mbps) Peak Data Rate</b>	<b>Uplink (Mbps) Peak Data Rate</b>
<b>HSPA as defined in Release 6</b>	14.4	5.76
<b>Release 7 HSPA+ DL 64 QAM, UL 16 QAM, 5+5 MHz</b>	21.1	11.5
<b>Release 7 HSPA+ 2X2 MIMO, DL 16 QAM, UL 16 QAM, 5+5 MHz</b>	28.0	11.5
<b>Release 8 HSPA+ 2X2 MIMO DL 64 QAM, UL 16 QAM, 5+5 MHz</b>	42.2	11.5
<b>Release 8 HSPA+ (no MIMO) Dual Carrier, 10+5 MHz</b>	42.2	11.5
<b>Release 9 HSPA+ 2X2 MIMO, Dual Carrier DL and UL, 10+10 MHz</b>	84.0	23.0
<b>Release 10 HSPA+ 2X2 MIMO, Quad Carrier<sup>93</sup> DL, Dual Carrier UL, 20+10 MHz</b>	168.0	23.0
<b>Release 11 HSPA+ 2X2 MIMO DL and UL, 8 Carrier DL, Dual Carrier UL, 40+10 MHz</b>	336.0	69.0

Figure 41 shows the cumulative distribution function of throughput values in a commercially deployed Release 8 HSPA+ network in an indoor-coverage scenario. The figure shows significant performance gains from higher-order modulation and MIMO.

---

<sup>93</sup> No operators have announced plans to deploy HSPA in a quad (or greater) carrier configuration. Three carrier configurations, however, have been deployed.

**Figure 41: HSPA+ Performance Measurements Commercial Network (5+5 MHz)<sup>94</sup>**

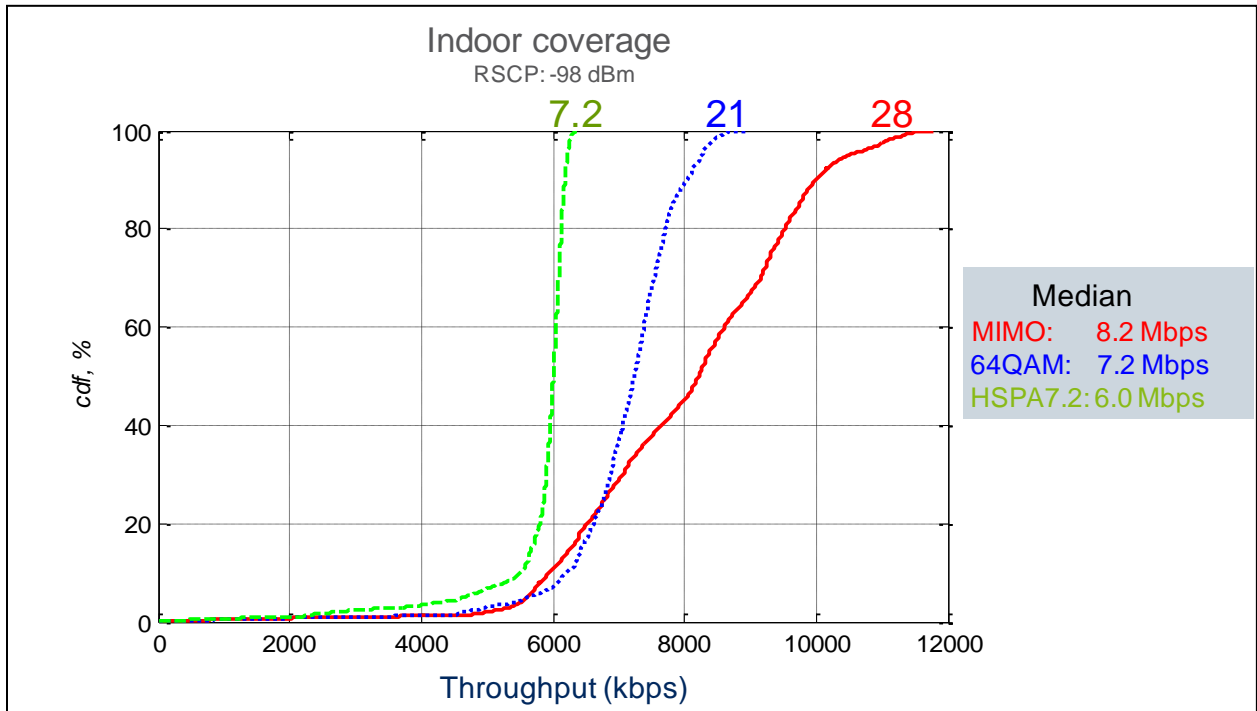

The figure shows a reasonably typical indoor scenario in a macro-cell deployment. Under better radio conditions, HSPA+ will achieve higher performance results.

Figure 42 shows the benefit of dual-carrier operation (no MIMO employed), which essentially doubles throughputs over single carrier operation.

---

<sup>94</sup> 4G Americas member company contribution.

**Figure 42: Dual-Carrier HSPA+ Throughputs<sup>95</sup>**

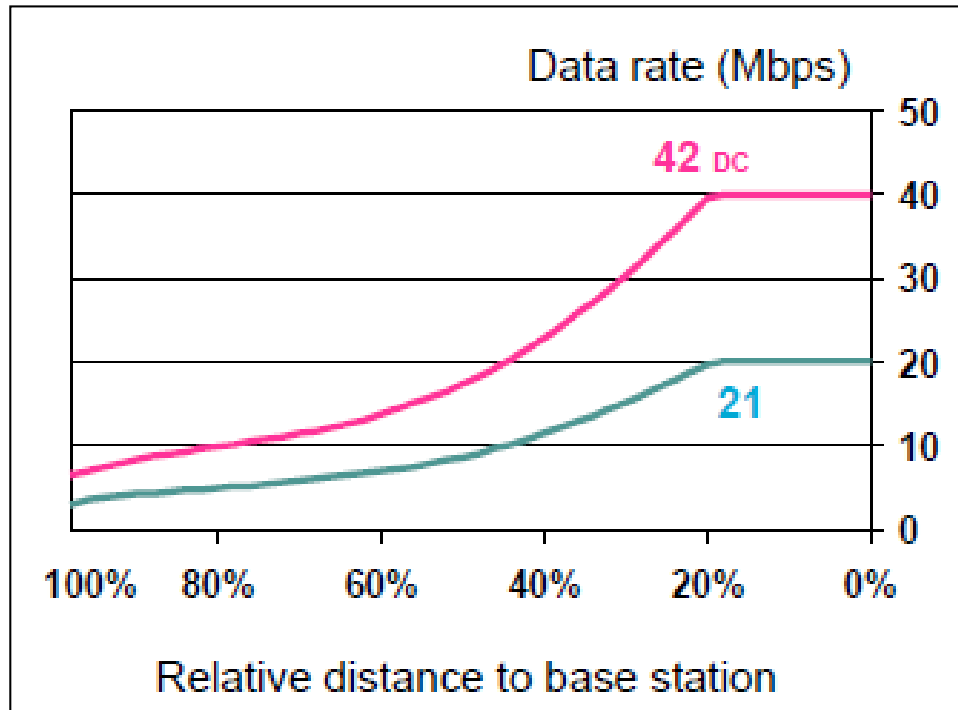

HSPA+ also has improved latency performance of as low as 25 msec and improved packet call setup time of below 500 msec.

Figure 43 summarizes the key capabilities and benefits of the features being deployed in HSPA+.

---

<sup>95</sup> 4G Americas member company contribution. 64 QAM.



**Figure 43: Summary of HSPA Functions and Benefits<sup>96</sup>**

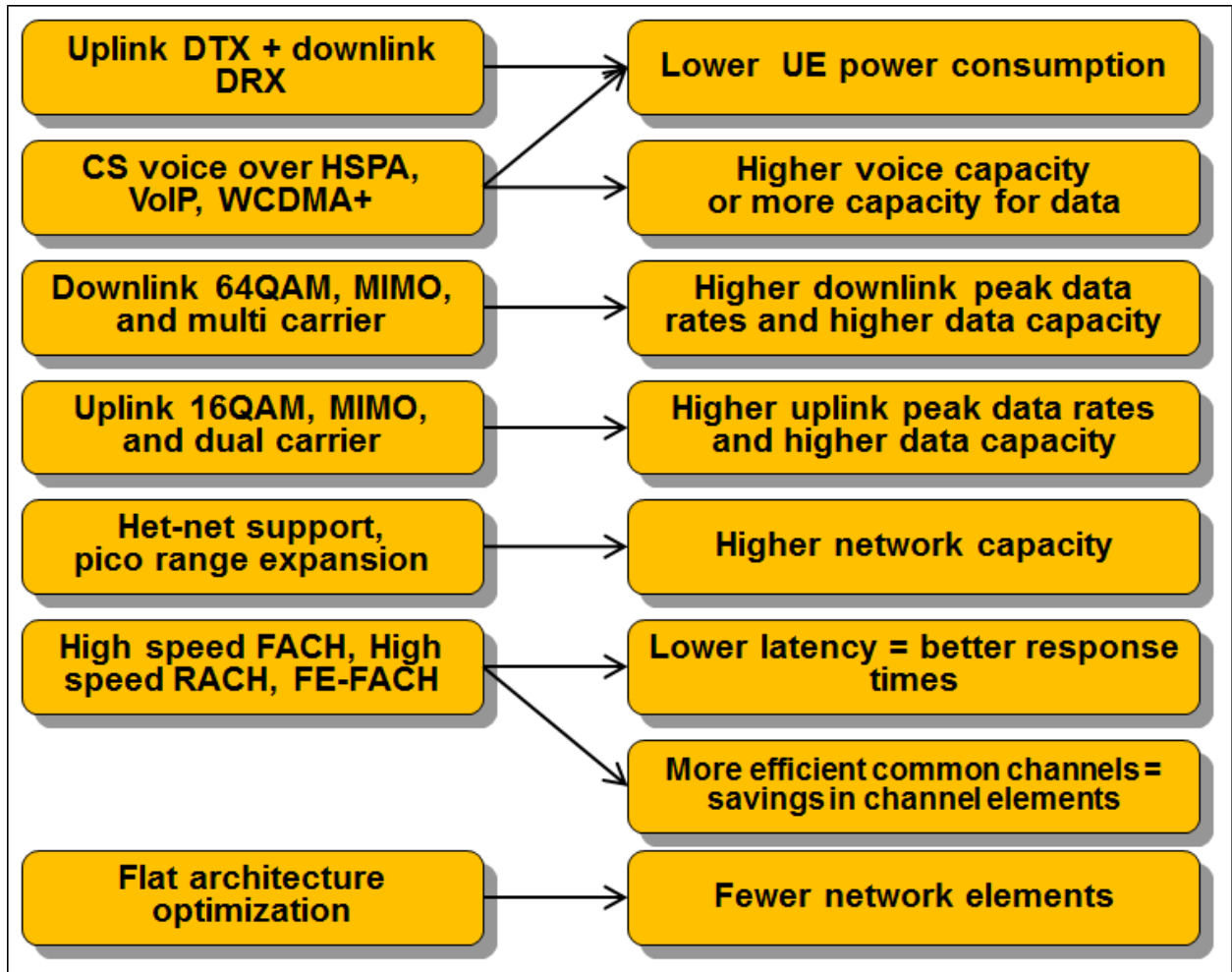

### **UMTS-HSPA Voice**

Circuit-switched voice using WCDMA dedicated channels in UMTS networks is spectrally very efficient. Moreover, current networks support simultaneous voice and data operation. Nevertheless, new voice approaches, including improved circuit-switched voice, circuit-switched voice over HSPA, and voice over Internet Protocol (VoIP), can further increase voice efficiency.

### **Improved Circuit-Switched Voice**

Release 12 includes a feature called "DCH Enhancements for UMTS" that improves circuit-switched voice capacity through a combination of approaches, including:

<sup>96</sup> 4G Americas member contribution.

- ❑ Reducing transmit-power overhead by eliminating the dedicated pilot and using the transmit-power control bits for channel estimation.
- ❑ Implementing a new, more efficient frame format that multiplexes two voice calls by splitting the 20 msec frame into two 10 msec halves.
- ❑ Terminating frame transmissions early once they are successfully decoded.
- ❑ Using the new Enhanced Voice Services (EVS) codec.

The motivation is not necessarily to support more voice calls, but to free up resources for data. The listed improvements result in only about half the radio resources needed to carry the same number of voice calls, with the remaining resources freed for data.

### Circuit-Switched (CS) Voice over HSPA

HSPA channels employ many optimizations for high data efficiency, which is why it makes sense to consider them to carry voice communications. Doing so with VoIP, however, requires supporting packetized voice not only in the radio channel but also within the infrastructure network. An alternative architecture, specified in Release 8, packetizes the circuit-switched voice traffic, which is already in digital form; uses the HSPA channels to carry the CS voice; and then connects the CS voice traffic back into the existing CS infrastructure (MSCs, etc.) immediately beyond the radio-access network. This architecture requires relatively straightforward changes in the radio network and devices, as shown in Figure 44.

**Figure 44: Implementation of HSPA CS Voice<sup>97</sup>**

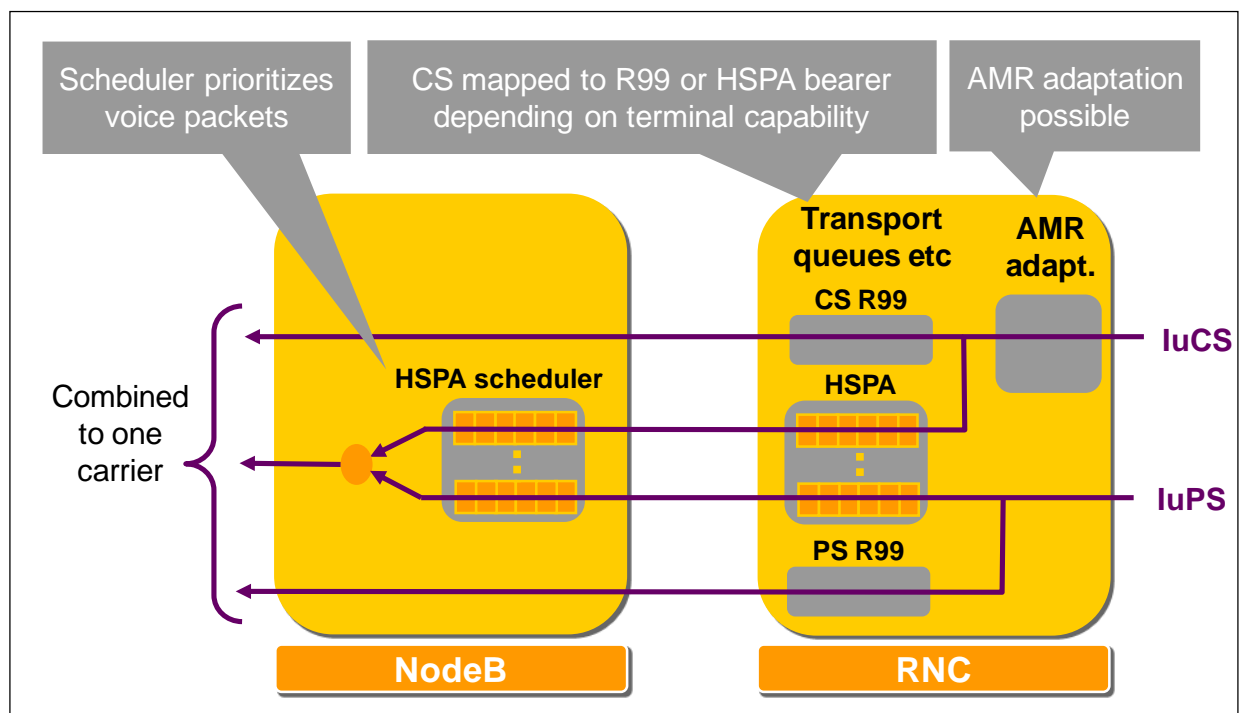

<sup>97</sup> 4G Americas, *UMTS Evolution from 3GPP Release 7 to Release 8*, 2007.

With CS Voice, legacy mobile phones can continue using WCDMA-dedicated traffic channels for voice communications, while new devices use HSPA channels. HSPA CS voice can be deployed with Release 7 or later networks and includes the following benefits:

- ❑ Relatively easy to implement and deploy.
- ❑ Transparent to existing CS infrastructure.
- ❑ Supports both narrowband and wideband codecs.
- ❑ Significantly improves battery life with voice communications.
- ❑ Enables faster call connections.
- ❑ Provides a 50% to 100% capacity gain over current voice implementations.
- ❑ Acts as a stepping stone to VoIP over HSPA/LTE in the future.

## **VoIP**

VoIP, another approach for HSPA introduced in Release 6 and enhanced in subsequent releases, can increase voice capacity, consolidate infrastructure on an IP platform, and enable innovative new applications that combine voice with data functions in the packet domain. VoIP operates over IMS, discussed later in this paper.

Operators can smoothly migrate users from circuit-switched operation to packet-switched operation over time. Because the UMTS radio channel supports both circuit-switched voice and packet-switched data, some voice users can be on legacy circuit-switched voice and others can be on VoIP. Figure 45 shows a system's voice capacity with the joint operation of circuit-switched and IP-based voice services.

**Figure 45: Ability for UMTS to Support Circuit and Packet Voice Users<sup>98</sup>**

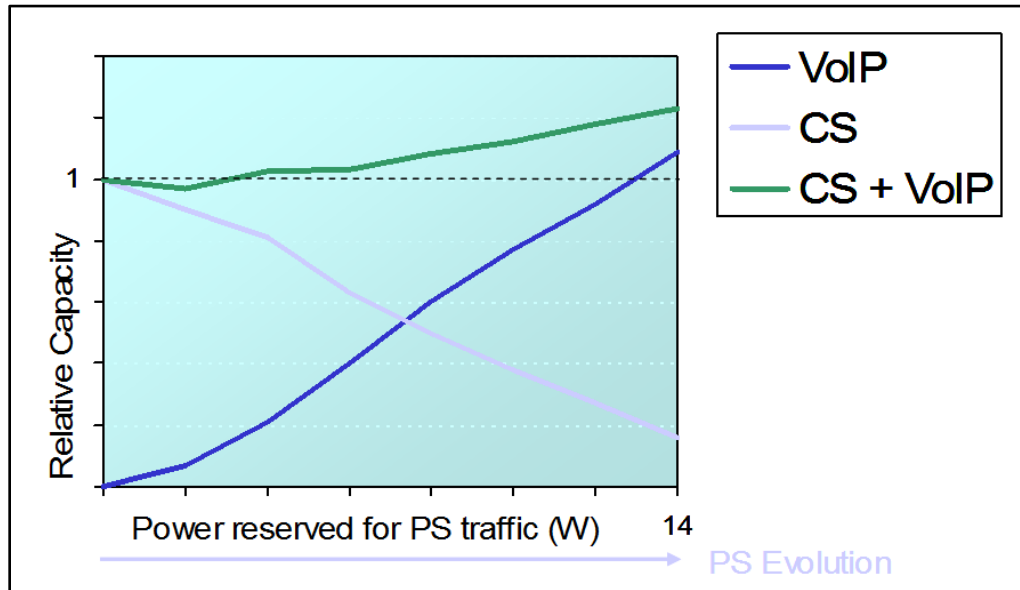

VoIP capacity gains range from 20 % to as high as 100 % with the implementation of interference cancellation and the minimization of IP overhead through a scheme called Robust Header Compression (ROHC).

Whereas packet voice is the only way voice will be supported in LTE, UMTS already has a highly efficient, circuit-switched voice service and already allows simultaneous voice/data operation. Moreover, packet voice requires a considerable amount of new infrastructure in the core network. Consequently, packet voice will likely be used initially as part of other services (for example, those based on IMS), and only over time might it transition to primary voice service.

## **LTE**

Although HSPA and HSPA+ offer a highly efficient broadband-wireless service that will enjoy success for the remainder of this decade and well into the next, 3GPP completed the specification for Long Term Evolution as part of Release 8. LTE offers even higher peak throughputs in wider spectrum bandwidth. Work on LTE began in 2004 with an official work item started in 2006 and a completed specification early 2009. Initial deployments began in 2010.

LTE uses OFDMA on the downlink, which is well suited to achieve high peak data rates in high-spectrum bandwidth. WCDMA radio technology is basically as efficient as OFDM for delivering peak data rates of about 10 Mbps in 5 MHz of bandwidth. Achieving peak rates in the 100 Mbps range with wider radio channels, however, would result in highly complex terminals, and it is not practical with current technology, whereas OFDM provides a practical implementation advantage. Scheduling approaches in the frequency

<sup>98</sup> 4G Americas member contribution.

domain can also minimize interference, thereby boosting spectral efficiency. The OFDMA approach is also flexible in channelization: LTE operates in various radio channel sizes ranging from 1.4 to 20 MHz.

On the uplink, however, a pure OFDMA approach results in high Peak to Average Ratio (PAR) of the signal, which compromises power efficiency and, ultimately, battery life. Hence, LTE uses an approach called SC-FDMA, which is somewhat similar to OFDMA, but has a 2 to 6 dB PAR advantage over the OFDMA method used by other technologies such as WiMAX.

LTE capabilities include:

- ❑ Downlink peak data rates up to 300 Mbps with 20+20 MHz bandwidth.
- ❑ Uplink peak data rates up to 71 Mbps with 20+20 MHz bandwidth.<sup>99</sup>
- ❑ Operation in both TDD and FDD modes.
- ❑ Scalable bandwidth up to 20+20 MHz covering 1.4, 3, 5, 10, 15, and 20 MHz radio carriers.
- ❑ Increased spectral efficiency over Release 6 HSPA by a factor of two to four.
- ❑ Reduced latency, to 15 msec round-trip times between user equipment and the base station, and to less than 100 msec transition times from inactive to active.
- ❑ Self-organizing capabilities under operator control and preferences that will automate network planning and will result in lower operator costs.

## LTE Throughput Rates

The overall objective is to provide an extremely high-performance radio-access technology that offers full vehicular speed mobility and that can readily coexist with HSPA and earlier networks. Because of scalable bandwidth, operators will be able to easily migrate their networks and users from HSPA to LTE over time.

Table 16 shows Release 8 LTE peak data rates based on different downlink and uplink designs.

**Table 16: LTE Peak Throughput Rates**

LTE Configuration	Downlink (Mbps) Peak Data Rate	Uplink (Mbps) Peak Data Rate
Using 2X2 MIMO in the Downlink and 16 QAM in the Uplink, 10+10 MHz	70.0	22.0
Using 4X4 MIMO in the Downlink and 64 QAM in the Uplink, 20+20 MHz	300.0	71.0

---

<sup>99</sup> Assumes 64 QAM. Otherwise 45 Mbps with 16 QAM.

LTE is not only efficient for data but, because of a highly efficient uplink, is extremely efficient for VoIP traffic. As discussed in the section above "Spectral Efficiency", In 10+10 MHz of spectrum, LTE VoIP capacity will reach 500 users.<sup>100</sup>

## OFDMA and Scheduling

LTE implements OFDM in the downlink. The basic principle of OFDM is to split a high-rate data stream into a number of parallel, low-rate data streams, each a narrowband signal carried by a subcarrier. The different narrowband streams are generated in the frequency domain, and then combined to form the broadband stream using a mathematical algorithm called an Inverse Fast Fourier Transform (IFFT) that is implemented in digital-signal processors. In LTE, the subcarriers have 15 kHz spacing from each other. LTE maintains this spacing regardless of the overall channel bandwidth, which simplifies radio design, especially in supporting radio channels of different widths. The number of subcarriers ranges from 72 in a 1.4 MHz radio channel to 1,200 in a 20 MHz radio channel.

The composite signal obtained after the IFFT is extended by repeating the initial part of the signal (called the Cyclic Prefix [CP]). This extended signal represents an OFDM symbol. The CP is basically a guard time during which reflected signals will reach the receiver. It results in an almost complete elimination of multipath-induced Intersymbol Interference (ISI), which otherwise makes extremely high data-rate transmissions problematic. The system is called orthogonal because the subcarriers are generated in the frequency domain (making them inherently orthogonal), and the IFFT conserves that characteristic.

OFDM systems may lose their orthogonal nature as a result of the Doppler shift induced by the speed of the transmitter or the receiver. 3GPP specifically selected the subcarrier spacing of 15 kHz to avoid any performance degradation in high-speed conditions. WiMAX systems that use a lower subcarrier spacing (~11 kHz) are more impacted in high-speed conditions than LTE.

**Figure 46: OFDM Symbol with Cyclic Prefix**

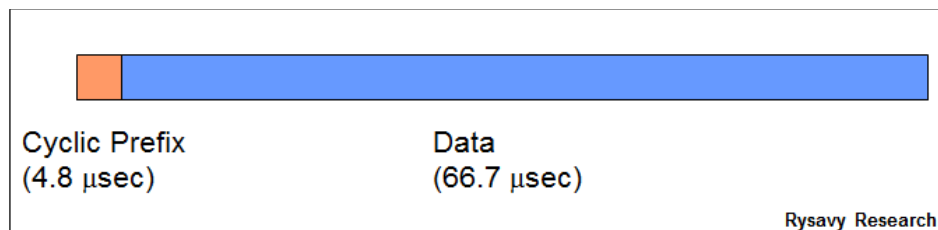

The multiple-access aspect of OFDMA comes from being able to assign different users different subcarriers over time. A minimum resource block that the system can assign to a user transmission consists of 12 subcarriers over 14 symbols in 1.0 msec. Figure 47 shows how the system can assign these resource blocks to different users over both time and frequency.

---

<sup>100</sup> 3GPP Multi-member analysis.

**Figure 47: LTE OFDMA Downlink Resource Assignment in Time and Frequency**

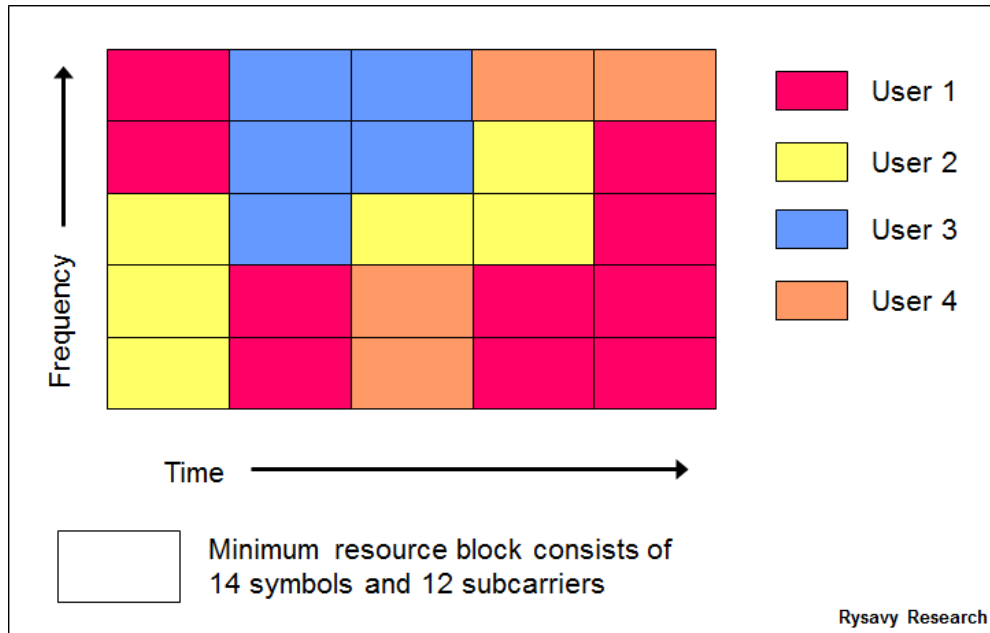

By controlling which subcarriers are assigned in which sectors, LTE can easily control frequency reuse. Using all the subcarriers in each sector, the system would operate at a frequency reuse of 1; but by using a different one third of the subcarriers in each sector, the system can achieve a looser frequency reuse of 1/3. The looser frequency reduces overall spectral efficiency, but delivers high peak rates to users.

Beyond controlling frequency reuse, frequency domain scheduling, as shown in Figure 48 can use those resource blocks that are not faded, not possible in CDMA-based systems. Since different frequencies may fade differently for different users, the system can allocate those frequencies for each user that result in the greatest throughput. This results in up to a 40% gain in average cell throughput for low user speed (3 km/hour), assuming a large number of users and no MIMO. The benefit decreases at higher user speeds.

**Figure 48: Frequency-Domain Scheduling in LTE<sup>101</sup>**

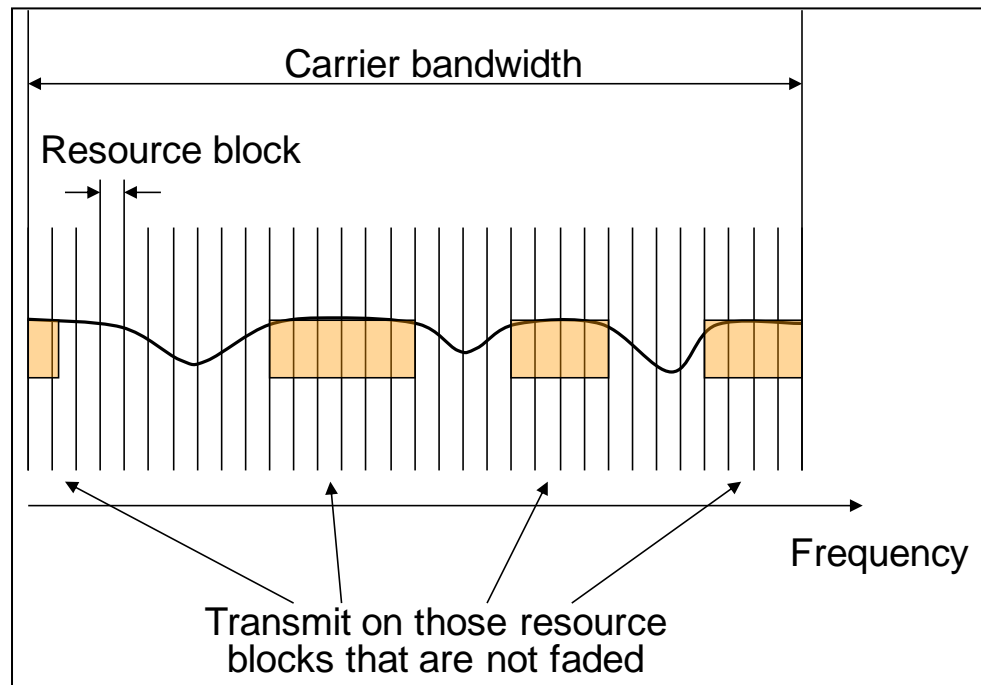

### LTE Smart Antennas

Wireless networks can achieve significant gains by employing multiple antennas, either at the base station, the mobile device, or both. LTE uses multiple antennas in three fundamentally different ways:

- ❑ **Diversity.** So long as the antennas are spaced or polarized appropriately, the antennas provide protection against fading.
- ❑ **Beamforming.** Multiple antennas can shape a beam to increase the gain for a specific receiver. Beamforming can also suppress specific interfering signals. Beamforming is particularly helpful for improving cell-edge performance.
- ❑ **Spatial Multiplexing.** Often referred to as MIMO antenna processing, spatial multiplexing creates multiple transmission paths through the environment, effectively sending data in parallel through these paths, thus increasing both throughput and spectral efficiency.

Table 17 shows the various antenna transmission modes.

---

<sup>101</sup> 4G Americas member contribution.



**Table 17: LTE Transmission Modes**<sup>102</sup>

Transmission Mode	Description
1	Single-antenna transmission.
2	Transmit diversity.
3	Transmit diversity for one layer, open-loop codebook-based precoding if more than one layer.
4	Closed-loop codebook-based precoding.
5	Multi-user MIMO version of transmission mode 4.
6	Special case of closed-loop codebook-based precoding limited to single-layer transmission.
7	Non-codebook-based precoding supporting one layer.
8	Release 9. Non-codebook-based precoding supporting up to two layers.
9	Release 10. Non-codebook-based precoding supporting up to eight layers.

Being able to exploit different antenna modes based on local conditions produces huge efficiency and performance gains, and is the reason that 3GPP is developing even more advanced antenna modes in subsequent LTE releases.

Precoding refers to a mathematical matrix operation performed on radio symbols to determine how they are combined and mapped onto antenna ports. The precoder matrix can operate in either open-loop or closed-loop modes. For each transmission rank for a given number of transmission ports (antennas), there is a limited set of precoder matrices defined, called the codebook. This helps limit the amount of signaling needed on uplink and downlink.

Fundamental variables distinguish the different antenna modes:

- ❑ **Single base-station antenna versus multiple antennas.** Single antennas provide for Single Input Single Output (SISO), SIMO, and planar-array beamforming. (Multiple Output means the UE has multiple antennas.) Multiple antennas at the base station provide for different MIMO modes such as 2X2, 4X2, and 4X4.
- ❑ **Single-user MIMO versus multi-user MIMO.** Release 8 only provides for single-user MIMO on the downlink. Release 10 includes multi-user MIMO.

---

<sup>102</sup> Erik Dahlman, Stefan Parkvall, Johan Skold, *4G - LTE/LTE Advanced for Mobile Broadband*, Academic Press, 2011.

- **Open Loop versus Closed Loop.** High vehicular speeds require open-loop operation whereas slow speeds enabled closed-loop operation in which feedback from the UE modifies the transmission. In closed-loop operation, the precoder matrix is based on this feedback.
- **Rank.** In a MIMO system, the channel rank is formally defined as the rank of the channel matrix and is a measure of the degree of scattering that the channel exhibits. For example, in a 2x2 MIMO system, a rank of one indicates a low-scattering environment, while a rank of two indicates a high-scattering environment. The rank two channel is highly uncorrelated, and is thus able to support the spatial multiplexing of two data streams, while a rank one channel is highly correlated, and thus can only support single stream transmission (the resulting multi-stream interference in a rank one channel as seen at the receiver would lead to degraded performance). Higher Signal to Interference plus Noise Ratios (SINR) are typically required to support spatial multiplexing, while lower SINRs are typically sufficient for single stream transmission. In a 4x4 MIMO system channel rank values of three and four are possible in addition to values of one and two. The number of data streams, however, or more specifically codewords in LTE is limited to a value of two. Thus, LTE has defined the concept of layers, in which the DL transmitter includes a codeword-to-layer mapping, and in which the number of layers is equal to the channel rank. An antenna mapping or precoding operation follows, which maps the layers to the antenna ports. A 4x2 MIMO system is also possible with LTE Release 8, but here the channel rank is limited to the number of UE antennas, which is equal to two.

The network can dynamically choose between different modes based on instantaneous radio conditions between the base station and the UE. Figure 49 shows the decision tree. The antenna configuration (AC) values refer to the transmission modes. Not every network will support every mode. Operators will choose which modes are the most effective and economical. AC2, 3, 4, and 6 are typical modes that will be implemented.

**Figure 49: Decision Tree for Different Antenna Schemes<sup>103</sup>**

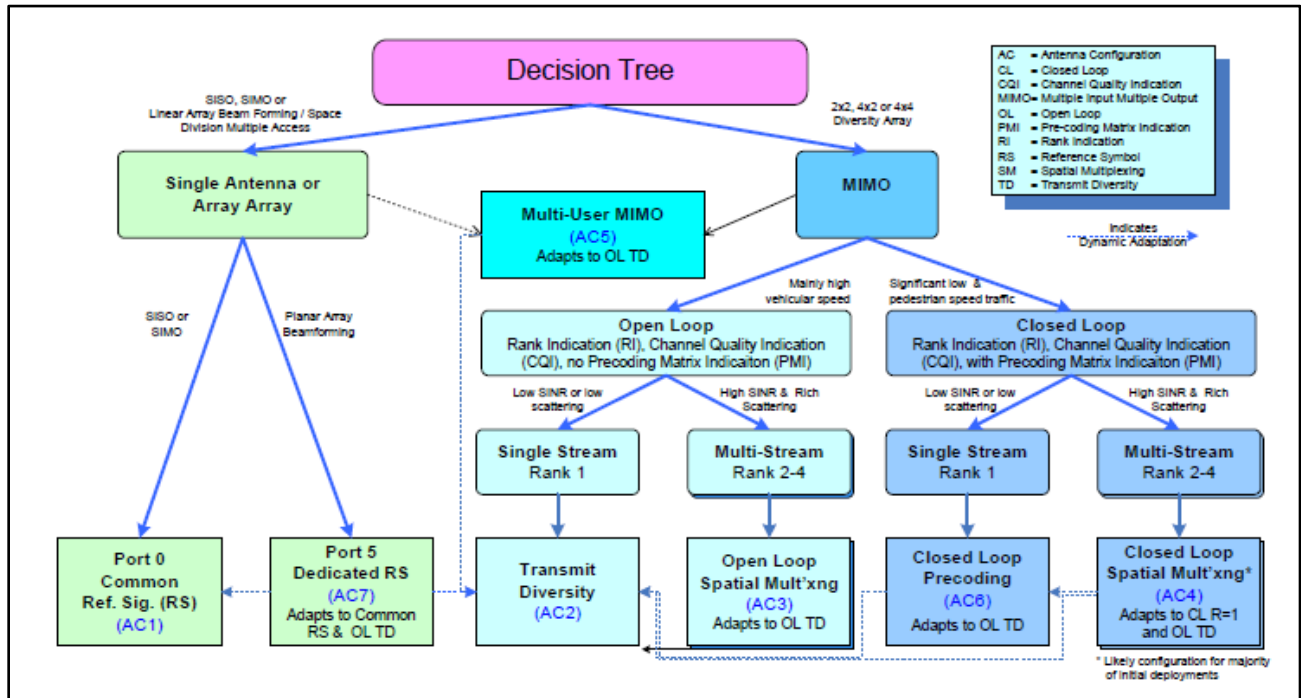

The simplest mode is AC2, referred to as Transmit Diversity (TD) or sometimes Space Frequency Block Code (SFBC) or even Open Loop Transmit Diversity. TD can operate under all conditions, meaning it works under low SINR, high mobility, and low channel rank (rank = 1). This rank means that the channel is not sufficiently scattered or de-correlated to support two spatial streams. Thus, in TD, only one spatial stream or what is sometimes referred to as a single codeword (SCW) is transmitted. If the channel rank increases to a value of two, indicating a more scattered channel, and the SINR is a bit higher, then the system can adapt to AC3 or Open-Loop Spatial Multiplexing (OL-SM), also referred to as large-delay Cyclic Delay Diversity (CDD). This mode supports two spatial streams or two codewords. This mode, also called multiple codeword (MCW) operation, increases throughput over SCW transmission.

If the rank of the channel is one, but the device is not moving very fast or is stationary, then the system can adapt to AC6, called closed-loop (CL) precoding (or CL-rank 1 or CL-R1). In this mode, the network receives from the device with Precoding Matrix Indication (PMI) bits that inform the base station what precoding matrix to use in the transmitter to optimize link performance. This feedback is only relevant for low-mobility or stationary conditions since in high mobility conditions the feedback will most likely be outdated by the time the base station can use it.

Another mode is AC4 or Closed Loop Spatial Multiplexing (CL-SM), which is enabled for low mobility, high SINR, and channel rank of two. This mode theoretically provides the

<sup>103</sup> 4G Americas *MIMO and Smart Antennas for 3G and 4G Wireless Systems – Practical Aspects and Deployment Considerations*, May 2010.

best user throughput. The figure above shows how these modes can adapt downwards to either OL TD, or if in CL-SM mode, down to either OL TD or CL R1.

For a 4x4 MIMO configuration, the channel rank can take on values of three and four in addition to one or two. Initial deployment at the base station, however, will likely be two TX antennas and most devices will only have 2 RX antennas, and thus the rank is limited to 2.

AC5 is MU-MIMO, which is not defined for the downlink in Release 8.

AC1 and AC7 are single antenna port modes in which AC1 uses a common Reference Signal (RS), while AC7 uses a dedicated RS or what is also called a user specific RS. AC1 implies a single TX antenna at the base station. AC7 implies an antenna array with antennal elements closely spaced so that a physical or spatial beam can be formed towards an intended user.

LTE operates in a variety of MIMO configurations. On the downlink, these include 2X2, 4X2 (four antennas at the base station), and 4X4. Initial deployment will likely be 2x2 whereas 4X4 will be most likely used initially in femtocells. On the uplink, there are two possible approaches: single-user MIMO (SU-MIMO) and multi-user MIMO (MU-MIMO). SU-MIMO is more complex to implement as it requires two parallel radio transmit chains in the mobile device, whereas MU-MIMO does not require any additional implementation at the device but relies on simultaneous transmission on the same tones from multiple mobile devices.

The first LTE release thus incorporates MU-MIMO with SU-MIMO deferred for subsequent LTE releases. An alternate form of MIMO, originally called network MIMO, and now called CoMP, relies on MIMO implemented (on either the downlink or uplink or both) using antennas across multiple base stations, as opposed to multiple antennas at the same base station. This paper explains CoMP in the section on LTE Advanced below.

Peak data rates are approximately proportional to the number of send and receive antennas. 4X4 MIMO is thus theoretically capable of twice the data rate of a 2X2 MIMO system. The spatial-multiplexing MIMO modes that support the highest throughput rates will be available in early deployments.

For a more detailed discussion of 3GPP antenna technologies, refer to the 4G Americas white paper "MIMO and Smart Antennas for 3G and 4G Wireless Systems – Practical Aspects and Deployment Considerations," May 2010.

For advancements in LTE smart antennas, see the section below on LTE-Advanced.

## **IPv4/IPv6**

Release 8 defines support for IPv6 for both LTE and UMTS networks. An Evolved Packet System bearer can carry both IPv4 and IPv6 traffic, enabling a UE to communicate both IPv4 and IPv6 packets (assuming it has a dual stack) while connected through a single EPS bearer. It is up to the operator, however, whether it assigns IPv4, IPv6, or both types of addresses to UE.

Communicating between IPv6-only devices and IPv4 end-points will require protocol-conversion or proxies. For further details, refer to the 4G Americas white paper, "IPv6 – Transition Considerations for LTE and Evolved Packet Core," February 2009.

## VoLTE and RCS

This paper introduced VoLTE and voice support in the earlier section, “VoLTE, RCS, WebRTC, and Wi-Fi Calling.” This section in the appendix provides additional technical detail about the operation of VoLTE and RCS.

Voice in LTE can encompass: no voice support, voice implemented in a circuit-switched fallback (CSFB) mode using 2G or 3G, and VoIP implemented with IMS.

Initial network deployments used CSFB, with which the LTE network carries circuit-switched signaling over LTE interfaces, allowing the subscriber to be registered with the 2G/3G MSC even while on the LTE network. When there is a CS event, such as an incoming voice call, the MSC sends the page to the LTE core network, which delivers it to the subscriber device. The device then switches to 2G/3G operation to answer the call.

Voice over LTE using VoIP requires IMS infrastructure. To facilitate IMS-based voice, vendors and operators created the One Voice initiative to define required baseline functionality for user equipment, the LTE access network, the Evolved Packet Core, and the IMS. GSMA adopted the One Voice initiative in what it calls Voice over LTE (VoLTE), specified in GSMA reference document IR.92.<sup>104</sup> GSMA specifies interconnection and international roaming among LTE networks through the IR.88<sup>105</sup> specification. Another specification, IR.94, provides the IMS Profile for Conversational Video Service, a service referred to as Video over LTE (ViLTE).<sup>106</sup>

For a phone to support VoLTE, it needs software implementing the IMS protocol stack. For example, the iPhone 6 was the first iPhone to implement such software. Additional software implementing RCS application programming interfaces can provide applications with access to IMS-based services, such as voice, messaging, and video. The Open Mobile Alliance has defined RESTful network APIs for RCS that support the following functions: notification channel, chat, file transfer, third-party calls, call notification, video sharing, image sharing, and capability discovery. As shown in Figure 50, over time, new profile releases will broaden the scope of these APIs.

---

<sup>104</sup> GSMA, “IMS Profile for Voice and SMS,” Document IR.92. Available at <http://www.gsma.com/newsroom/wp-content/uploads/2013/04/IR.92-v7.0.pdf>.

<sup>105</sup> GSMA, “LTE Roaming Guidelines,” GSMA Document IR.88. Available at <http://www.gsma.com/newsroom/wp-content/uploads/2013/04/IR.88-v9.0.pdf>.

<sup>106</sup> GSMA, “IMS Profile for Conversational Video Service,” Document IR.94. Available at <http://www.gsma.com/newsroom/all-documents/ir-94-ims-profile-for-conversational-video-service/>.

**Figure 50: Evolution of RCS API Profiles<sup>107</sup>**

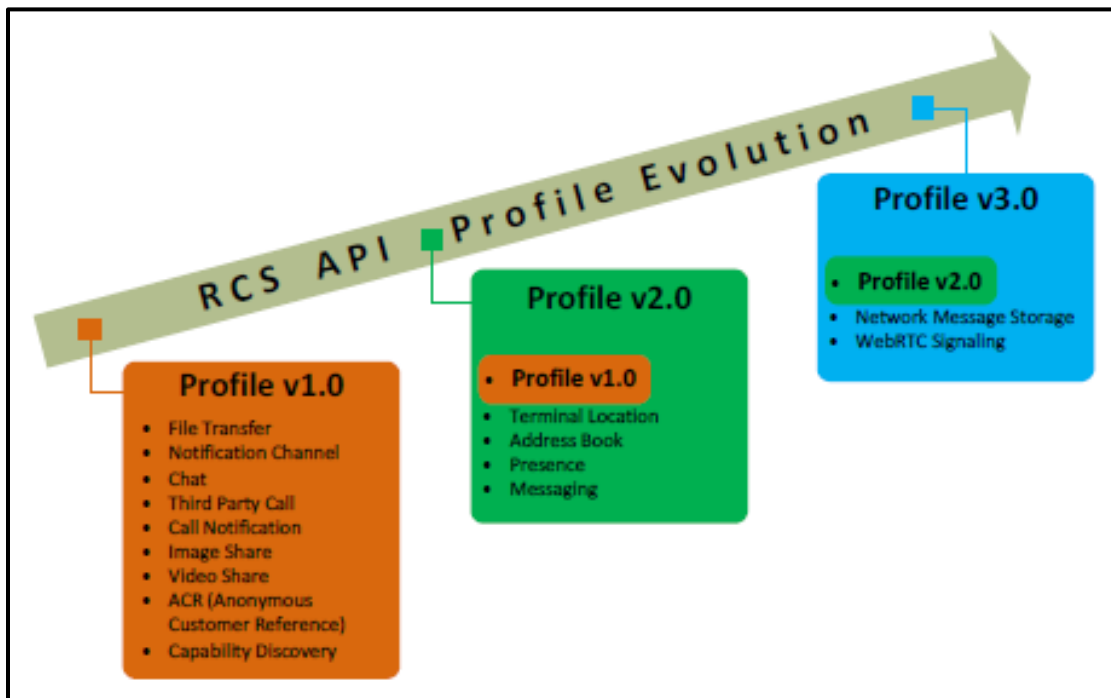

LTE VoIP leverages the QoS capabilities defined for EPC, which specify different quality classes. Features available in LTE to make voice operation more efficient include Semi-Persistent Scheduling (SPS) and TTI bundling. SPS reduces control channel overhead for applications (like VoIP) that require a persistent radio resource. Meanwhile, TTI bundling improves subframe utilization by reducing IP overhead, while in the process optimizing uplink coverage.

Another way to increase voice capacity in LTE and to support operation in congestion situations is vocoder rate adaptation, a mechanism with which operators can control the codec rate based on network load, thus dynamically trading off voice quality against capacity.

VoLTE roaming across operators will require network-to-network interfaces between their respective IMS networks. Such roaming and interconnect will follow initial VoLTE deployments. Different IMS stack implementations between vendors will also complicate roaming.

One roaming consideration is how operators handle data roaming. LTE roaming can send all visited network traffic back to the home network, which for a voice call, increases voice latency. For voice calls, the local-breakout option would mitigate this latency.

Using Single-Radio Voice Call Continuity (SR-VCC) and Enhanced SRVCC (eSRVCC), user equipment can switch midcall to a circuit-switched network, in the event that the user moves out of LTE coverage. Similarly, data sessions can be handed over in what is called Packet Switched Handover (PSHO).

---

<sup>107</sup> 4G Americas, *VoLTE and RCS Technology – Evolution and Ecosystem*, November 2014.

Figure 51 shows how an LTE network might evolve in three stages. Initially, LTE performs only data service, and the underlying 2G/3G network provides voice service via CSFB. In the second stage, voice over LTE is available, but LTE covers only a portion of the total 2G/3G coverage area. Hence, voice in 2G/3G can occur via CSFB or SR-VCC. Eventually, LTE coverage will match 2G/3G coverage, and LTE devices will use only the LTE network.

**Figure 51: Evolution of Voice in an LTE Network<sup>108</sup>**

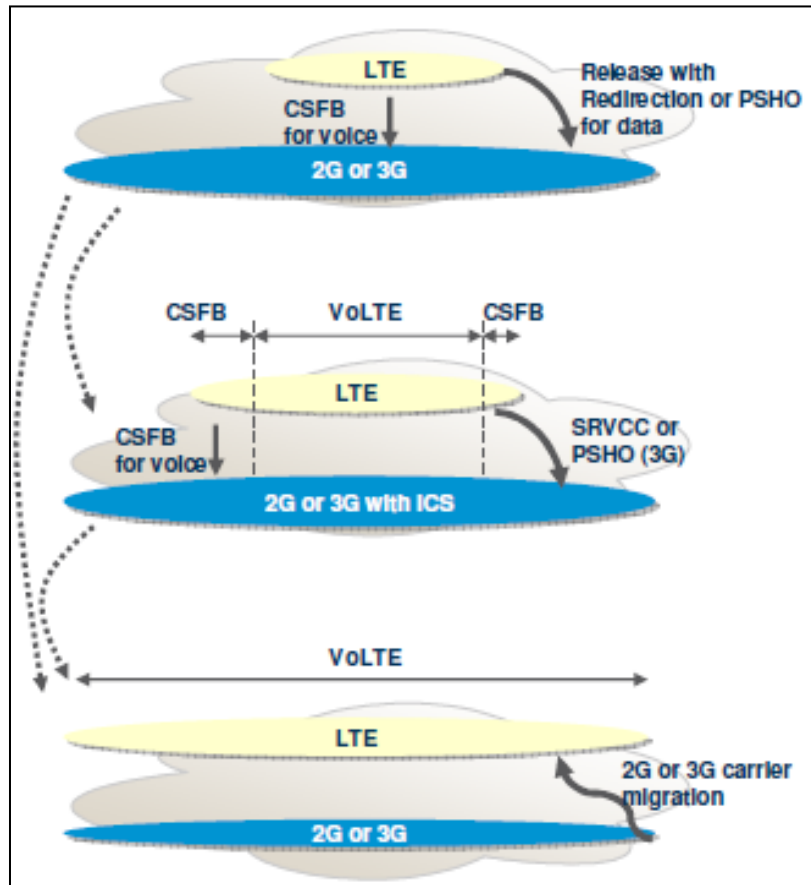

Another voice approach, called Voice over LTE via Generic Access (VoLGA), defined circuit-switched operation through an LTE IP tunnel. 3GPP, however, has stopped official standards work that would support VoLGA.

3GPP has developed a new codec, called Enhanced Voice Services (EVS), which will include super-wideband voice capability. For the same bit rate, EVS provides higher voice quality than the other codecs.<sup>109</sup> Table 18 summarizes the features and parameters of the three 3GPP codecs used in LTE.

<sup>108</sup> 4G Americas member contribution.

<sup>109</sup> See Figure 9.2. 3GPP, *TR 26.952 V12.1.0, Codec for Enhanced Voice Services (EVS); Performance Characterization*, March 2015.

**Table 18: Comparison of AMR, AMR-WB and EVS Codecs<sup>110</sup>**

Features	AMR	AMR-WB	EVS
Input and output sampling frequencies supported	8KHz	16KHz	8KHz, 16KHz, 32KHz, 48 KHz
Audio bandwidth	Narrowband	Wideband	Narrowband, Wideband, Super-wideband, Fullband
Coding capabilities	Optimized for coding human voice signals	Optimized for coding human voice signals	Optimized for coding human voice and general-purpose audio (music, ringtones, mixed content) signals
Bit rates supported (in kb/s)	4.75, 5.15, 5.90, 6.70, 7.4, 7.95, 10.20, 12.20	6.6, 8.85, 12.65, 14.25, 15.85, 18.25, 19.85, 23.05, 23.85	5.9, 7.2, 8, 9.6 (NB and WB only), 13.2 (NB, WB and SWB), 16.4, 24.4, 32, 48, 64, 96, 128 (WB and SWB only)
Number of audio channels	Mono	Mono	Mono and Stereo
Frame size	20 ms	20 ms	20 ms
Algorithmic Delay	20-25 ms	25 ms	Up to 32 ms

Figure 52 shows mean opinion scores (MOS) for different codecs at different bit rates, illustrating the advantage of EVS, particularly for bit rates below 32 kbps that cellular networks use.

<sup>110</sup> 4G Americas, *Mobile Broadband Evolution: Rel-12 & Rel-13 and Beyond*, 2015.



**Figure 52: Combined Mean Opinion Score Values.** <sup>111</sup>

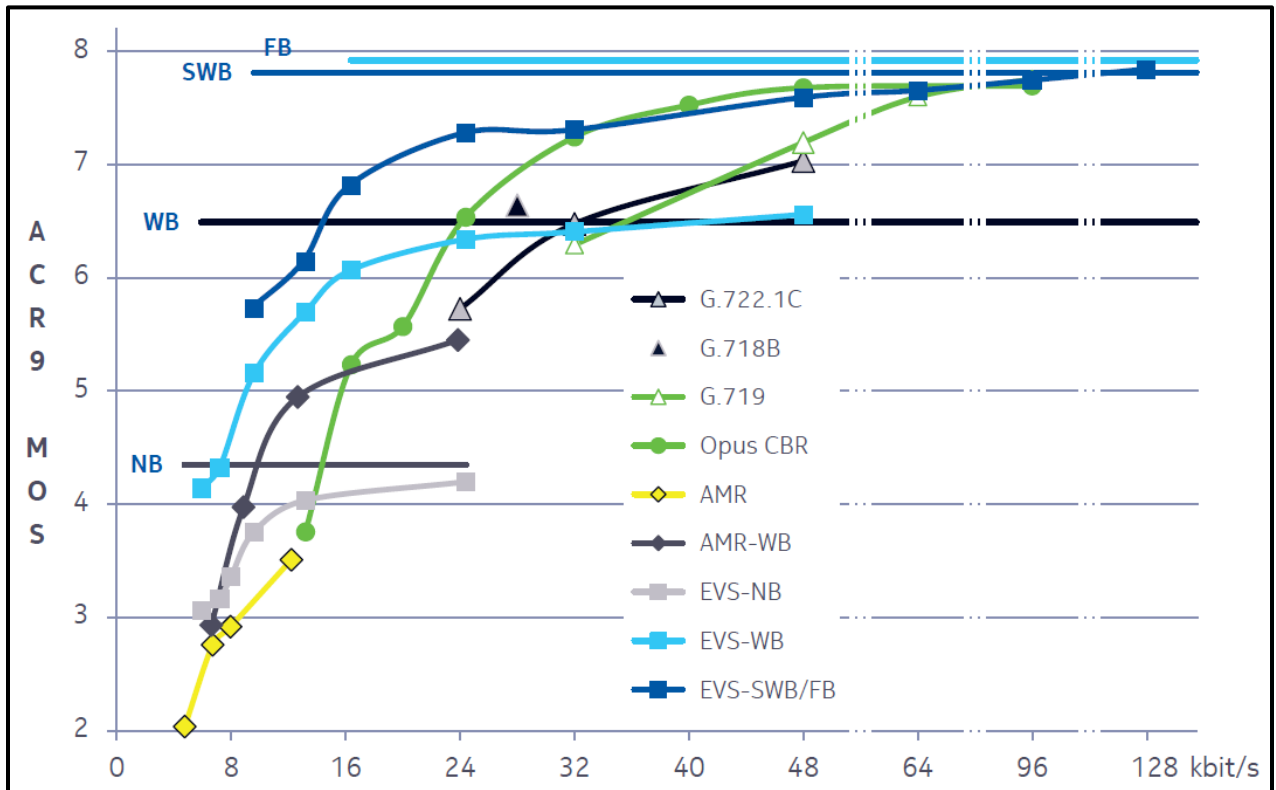

Table 19 shows EVS (narrowband, wideband, super-wideband) audio bandwidths and bitrates that create subjective quality equal to or better than AMR or AMR-WB for typical conversational voice scenarios.

**Table 19: EVS Compared to AMR and AMR-WB** <sup>112</sup>

Reference	Equal bandwidth	Wider bandwidth
AMR 12.2 kbit/s	EVS-NB 8.0 kbit/s	EVS-WB 5.9 kbit/s
AMR-WB 12.65 kbit/s	EVS-WB 9.6 kbit/s	EVS-SWB 9.6 kbit/s
AMR-WB 23.85 kbit/s	EVS-WB 13.2 kbit/s	EVS-SWB 9.6 kbit/s

Figure 53 compares EVS capacity gains over AMR and AMR-WB for the references cases shown in Table 19. EVS-SWB at 9.6 kbps almost doubles voice capacity compared to AMW-WB at 23.85 kbps.

<sup>111</sup> Nokia, *The 3GPP Enhanced Voice Services (EVS) codec*, 2015. Available at <http://networks.nokia.com/file/41551/the-3gpp-enhanced-voice-services-evs-codec>.

<sup>112</sup> Ibid.

**Figure 53: EVS Voice Capacity Compared to AMR and AMR-WB <sup>113</sup>**

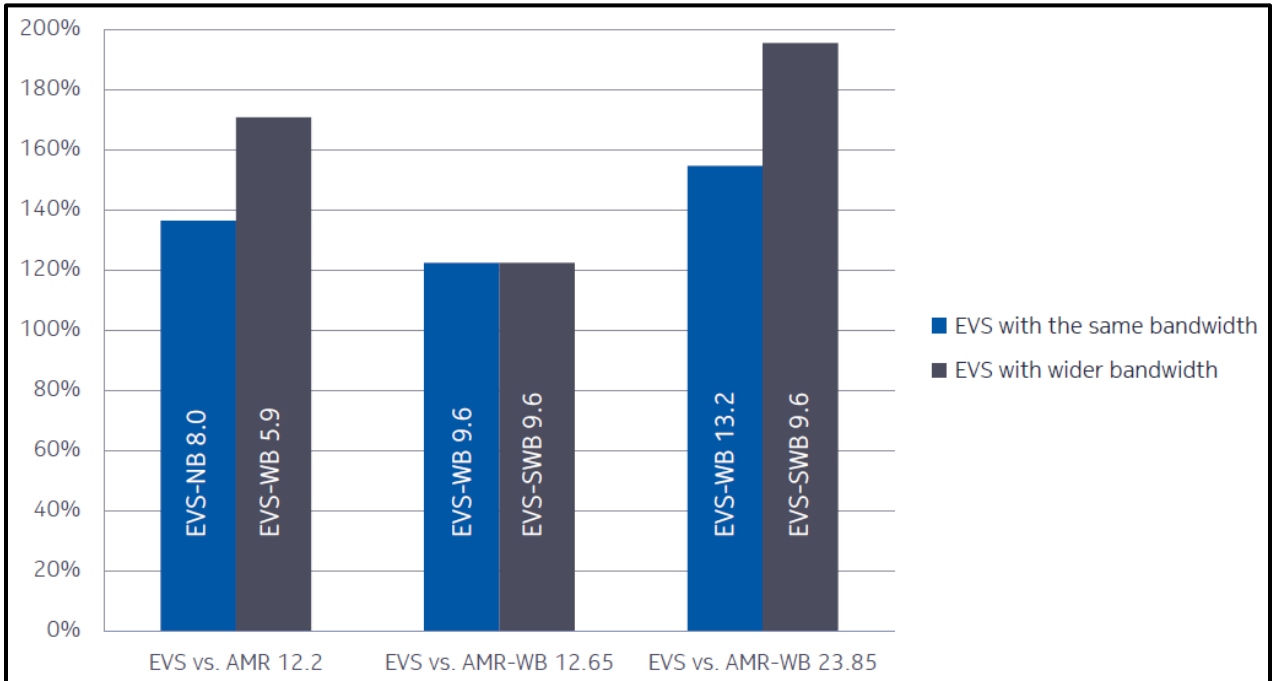

### TDD Harmonization

3GPP developed LTE TDD to be fully harmonized with LTE FDD including alignment of frame structures, identical symbol-level numerology, the possibility of using similar reference signal patterns, and similar synchronization and control channels. Also, there is only one TDD variant. Furthermore, LTE TDD has been designed to co-exist with TD-SCDMA and TD-CDMA/UTRA (both low-chip rate and high-chip rate versions). LTE TDD achieves compatibility and co-existence with TD-SCDMA by defining frame structures in which the DL and UL time periods can be time aligned to prevent BTS to BTS and UE to UE interference to support operation in adjacent carriers without the need for large guardbands between the technologies. This will simplify deployment of LTE TDD in countries such as China that are deploying TD-SCDMA. Figure 54 demonstrates the synchronization between TC-SCDMA and LTE-TDD in adjacent channels.

<sup>113</sup> Ibid.

**Figure 54: TDD Frame Co-Existence between TD-SCDMA and LTE TDD<sup>114</sup>**

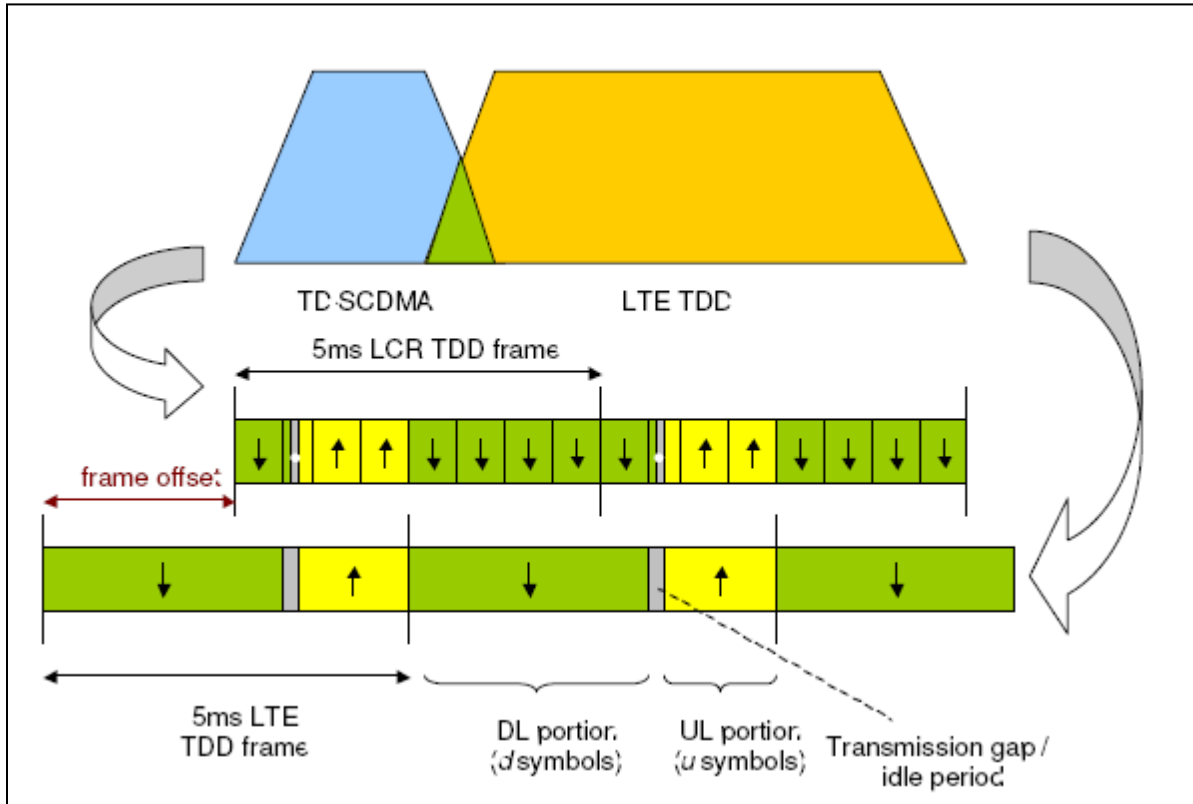

For LTE FDD and TDD to coexist, large guardbands will be needed to prevent interference.

## SMS in LTE

Even if an LTE network uses CSFB for voice, LTE devices will be able to send and receive SMS messages while on the LTE network. In this case, the 2G/3G core network will handle SMS messaging, but will tunnel the message to the MME in the EPC via the SGs interface. Once an LTE network uses IMS and VoLTE for packet voice service, SMS will be handled as SMS over IP and will use IMS infrastructure.<sup>115</sup>

## LTE-Advanced

LTE-Advanced, as specified in Release 10, is a term used for the version of LTE that addresses IMT-Advanced requirements. The ITU ratified LTE-Advanced as IMT-Advanced in November 2010. LTE-Advanced is both backward- and forward-compatible with LTE, meaning LTE devices will operate in newer LTE-Advanced networks, and LTE-Advanced devices will operate in older LTE networks.

<sup>114</sup> 4G Americas member company contribution.

<sup>115</sup> For further details, see 4G Americas, *Coexistence of GSM, HSPA and LTE*, May 2011, 35.

The following lists at a high level the most important features of LTE-Advanced, as well as other features planned for subsequent releases, including Release 11:

- ❑ Carrier aggregation.
- ❑ Higher-order downlink MIMO (up to 8X8 in Release 10).
- ❑ Uplink MIMO (two transmit antennas in the device).
- ❑ Coordinated multipoint transmission (CoMP) in Release 11.
- ❑ Heterogeneous network (HetNet) support including enhanced Inter-Cell Interference Coordination (eICIC).
- ❑ Relays.

The following sections describe these various features in greater detail.

### **Carrier Aggregation**

Carrier aggregation, first available in Release 10, will play an important role in providing operators maximum flexibility for using all of their available spectrum. By combining spectrum blocks, LTE can deliver much higher throughputs than otherwise possible. Asymmetric aggregation (for example, different amounts of spectrum used on the downlink versus the uplink) provides further flexibility and addresses the greater demand on downlink traffic.

Specific types of aggregation include:

- ❑ Intra-band on adjacent channels.
- ❑ Intra-band on non-adjacent channels.
- ❑ Inter-band (700 MHz, 1.9 GHz).
- ❑ Inter-technology (for example, LTE on one channel, HSPA+ on another). This approach is not currently specified nor being developed. While theoretically promising, a considerable number of technical issues would have to be addressed.<sup>116</sup> See Figure 55.

---

<sup>116</sup> For further details, see 4G Americas, *HSPA+ LTE Carrier Aggregation*, June 2012.

**Figure 55: Inter-Technology Carrier Aggregation<sup>117</sup>**

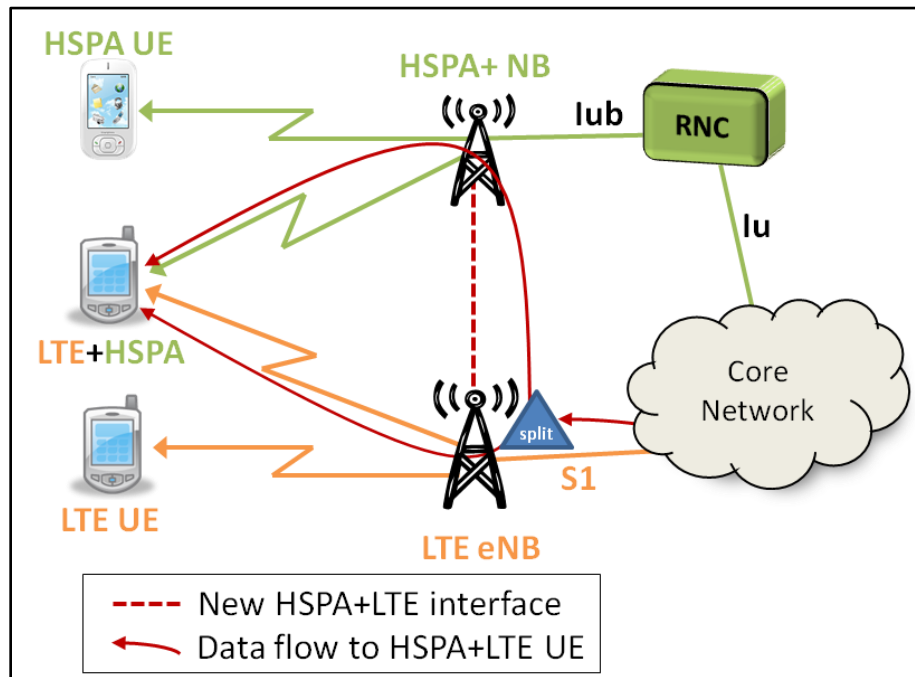
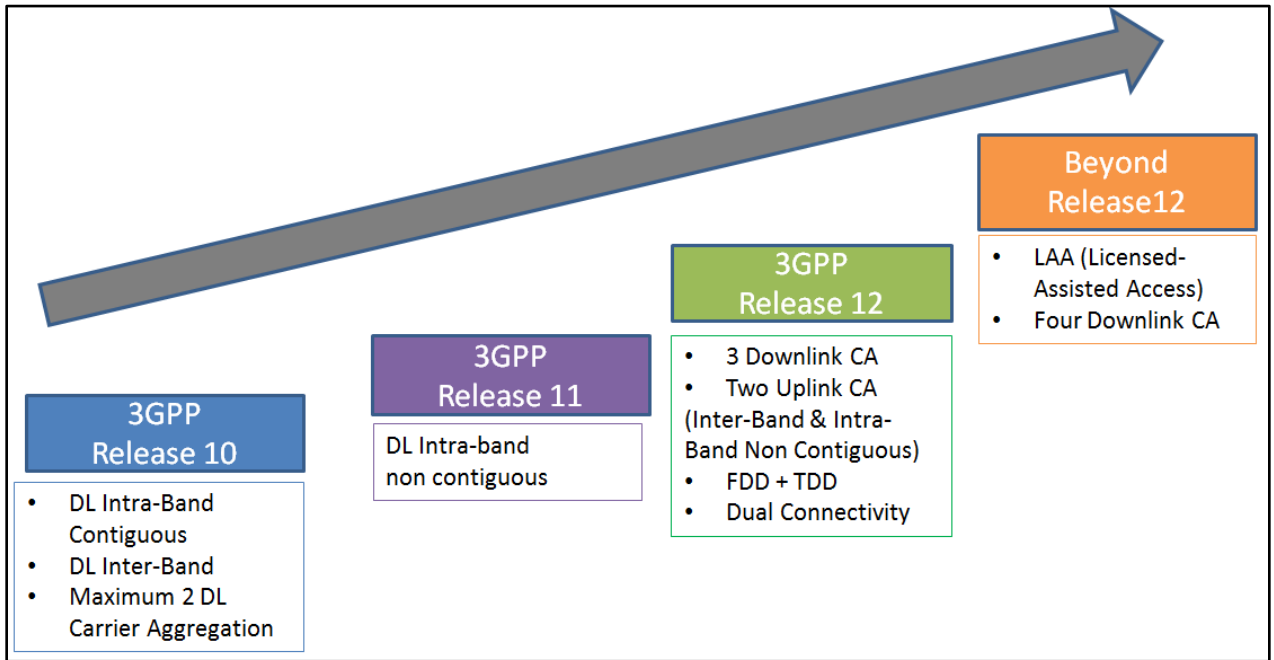

Figure 56 depicts the carrier-aggregation capabilities of different 3GPP releases.

<sup>117</sup> 4G Americas member contribution.

**Figure 56: Carrier Aggregation Capabilities across 3GPP Releases<sup>118</sup>**



One anticipated benefit of inter-band aggregation stems from using the lower-frequency band for users who are at the cell edge, to boost their throughput rates. Though this approach improves average aggregate throughput of the cell by only a small amount (say, 10%), it results in a more uniform user experience across the cell coverage area.

Figure 57 shows an example of intra-band carrier aggregation using adjacent channels with up to 100+100 MHz of bandwidth supported. Radio-access network specifications, however, limit the number of carriers to two in Release 10 and Release 11.

<sup>118</sup> 4G Americas, *Mobile Broadband Evolution: Rel-12 & Rel-13 and Beyond*, 2015.

**Figure 57: Release 10 LTE-Advanced Carrier Aggregation**<sup>119</sup>

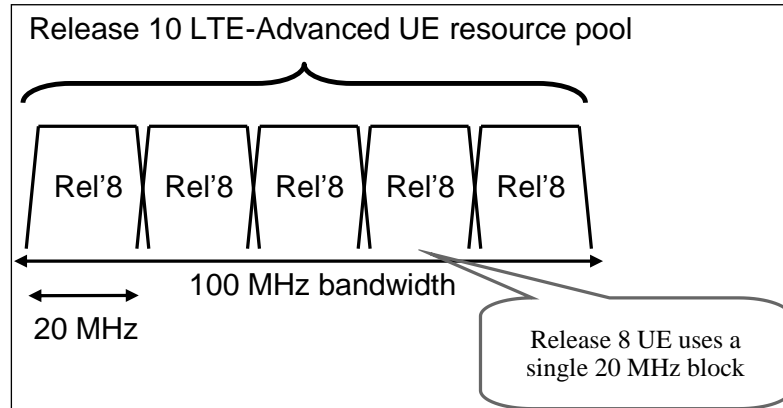
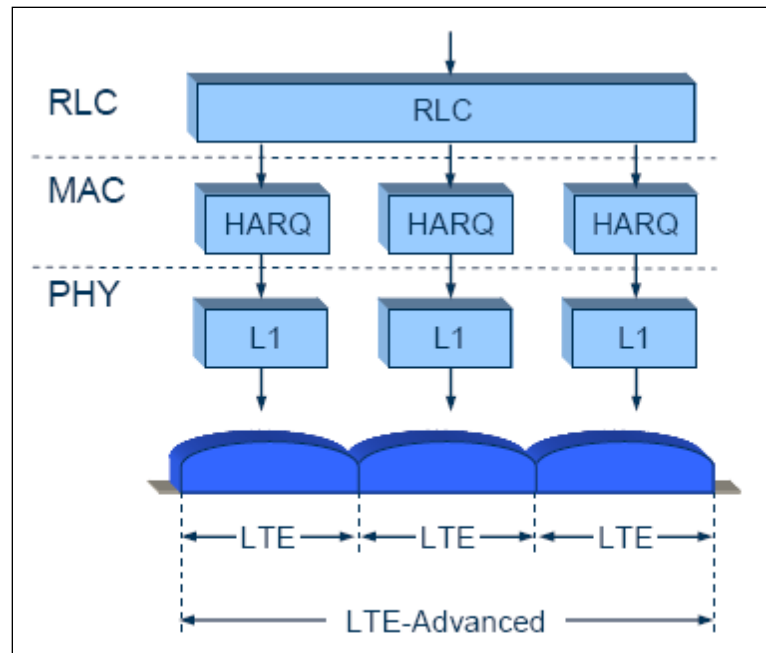

Figure 58 shows the carrier aggregation operating at different protocol layers.

**Figure 58: Carrier Aggregation at Different Protocol Layers**<sup>120</sup>



<sup>119</sup> Harri Holma and Antti Toskala, *LTE for UMTS, OFDMA and SC-FDMA Based Radio Access*, Wiley, 2009.

<sup>120</sup> Stefan Parkvall and David Astely, Ericsson Research, "The Evolution of LTE towards IMT-Advanced," *Journal of Communications*, Vol. 4, No. 3, April 2009. Available at <http://www.academypublisher.com/jcm/vol04/no03/jcm0403146154.pdf>.

Intra-band CA combinations being defined in the Release 11 timeframe include:

**Table 20: Intra-Band Carrier Aggregation**

Case No.	Band No.	Common Names	Carrier Examples
1	7	Intra-Band 2600	China Unicom
2	38	Intra-Band MBS of 2.6 GHz	China Mobile
3	40	Intra-Band IMT 2000	
4	41	Intra-Band 2600 BRS/EBS	Clearwire

Inter-Band CA combinations defined in the Release 11 timeframe include:

**Table 21: Inter-Band Carrier Aggregation**

Case No.	Band No.	Common Names	Carrier Examples
1	1+5	2100+cellular	
2	1+18	2100+ESMR	KDDI
3	1+19	2100+880	NTT DoCoMo
4	1+21	2100+1.5G	NTT DoCoMo
5	2+17	PCS+B&C	AT&T
6	3+5	1800+cellular	SK Telecom
7	3+7	1800+2.6	TeliaSonera
8	3+8	1800+900	KT
9	3+20	1800+Digital Dividend	Vodafone
10	4+5	AWS+Cellular	AT&T
11	4+7	AWS+2.6	Rogers Wireless
12	4+12	AWS+ABC	Leap
13	4+13	AWS+Upper C	Ericsson VZW
14	4+17	AWS+B&C	AT&T
15	5+12	Cellular+ABC	US Cellular
16	5+17	Cellular+B&C	AT&T
17	7+20	2.6+Digital Dividend	Orange
18	8+20	900+Digital Dividend	Vodafone
19	11+18	PDC+ESMR	KDDI



For Release 12, 3GPP has defined a significant number of additional band combinations.<sup>121</sup>

Carrier aggregation improves performance not only by combining the capacity of two or more different radio channels, but also through trunking efficiency, which refers to packets being able to traverse through either of the channels and solving the problem of one being congested while the other is idle.

Figure 59 shows the result of one simulation study that compares download throughput rates between the blue line, which shows five user devices in 700 MHz and five user devices in AWS not using CA, and the pink line, which shows ten user devices that have access to both bands. Assuming a lightly loaded network with CA, 50% or more users (the median) experience 91% greater throughput, and 95% or more users experience 50% greater throughput. These trunking gains are less pronounced in heavily loaded networks.

---

<sup>121</sup> 4G Americas, *4G Mobile Broadband – 3GPP Release 11 & Release 12 and Beyond*, Appendix A, “Table 5.2, EUTRA Inter-Band Carrier Aggregation cases through current working view of Rel-12.” Available at <http://www.4gamericas.org/documents/4G%20Mobile%20Broadband%20Evolution%20Rel-11%20%20Rel%2012%20and%20Beyond%20Feb%202014%20-%20FINAL.pdf>.

**Figure 59: Gains from Carrier Aggregation<sup>122</sup>**

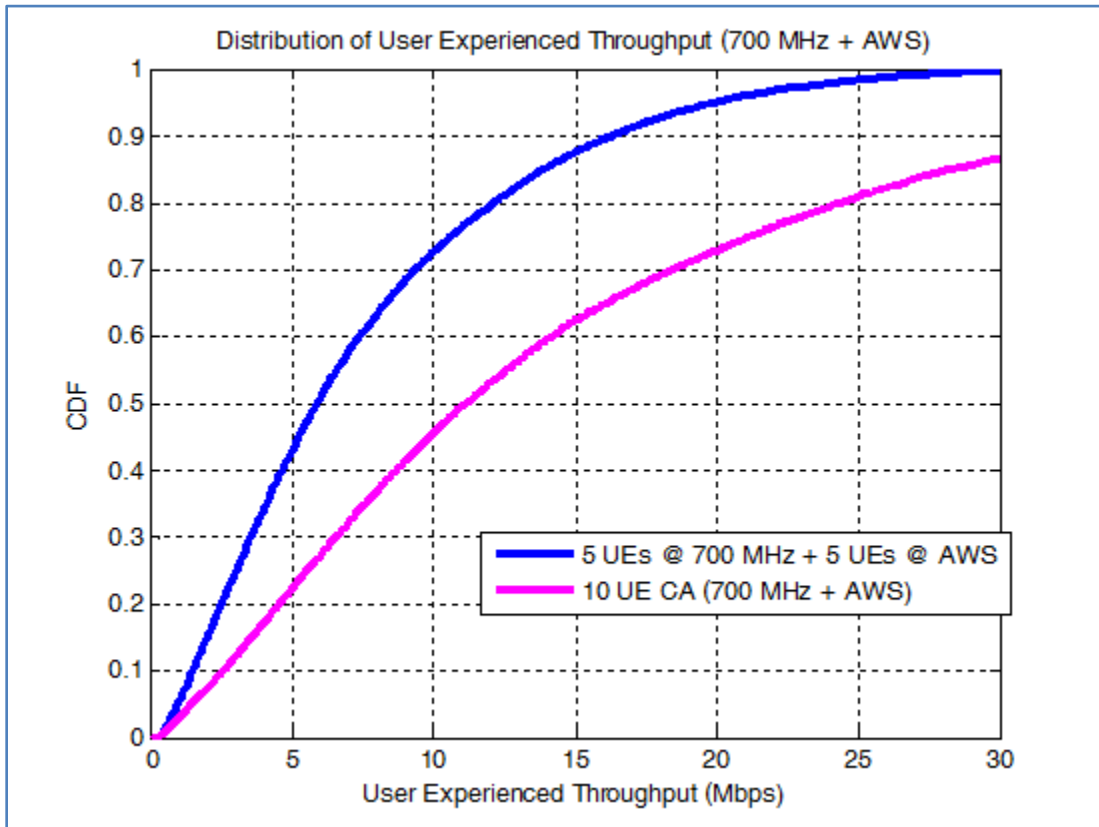

Work in Release 12 is investigating aggregation of joint TDD and FDD carriers.

### **LTE-Advanced Antenna Technologies**

Release 10 includes significant enhancements to antenna capabilities, including four-layer transmission resulting in peak spectral efficiency exceeding 15 bps/Hz. Uplink techniques fall into two categories: those relying on channel reciprocity and those that do not. With channel reciprocity, the eNB determines the channel state by processing a sounding reference signal from the UE. It then forms transmission beams accordingly. The assumption is that the channel received by the eNB is the same as the UE. Techniques that use channel reciprocity are beamforming, SU-MIMO, and MU-MIMO. Channel reciprocity works especially well with TDD since both forward and reverse links use the same frequency.

Non-reciprocity approaches apply when the transmitter has no knowledge of the channel state. Techniques in this instance include open-loop MIMO, closed-loop MIMO, and MU-MIMO. These techniques are more applicable for higher speed mobile communications.

For the downlink, the technology can transmit in as many as eight layers using an 8X8 configuration for a peak spectral efficiency of 30 bps/Hz. This exceeds the IMT-Advanced

<sup>122</sup> 4G Americas member contribution. Assumptions: lightly-loaded network, 2.0 site-to-site distance, file size is 750 Kbytes, traffic model bursty with mean inter-arrival time of five seconds,

requirements, conceivably supporting a peak rate of 1 Gbps in just 40+40 MHz, and even higher rates in wider bandwidths. This would require additional reference signals for channel estimation and for measurements, including channel quality, to enable adaptive, multi-antenna transmission.

Release 10 supports a maximum of two codewords, the same as previous LTE releases. The release specifies a new transmission mode (TM-9) that supports SU-MIMO up to Rank 8 (up to eight layers), as well as the ability to dynamically switch between SU-MIMO and MU-MIMO.

Figure 60 shows the different forms of single-user MIMO in Releases 8, 9, and 10. Release 8 supports only a single layer, whereas two-layer beamforming is possible in Release 9, and eight layers are possible in Release 10 with eight antennas at the base station.

**Figure 60: Single-User MIMO<sup>123</sup>**

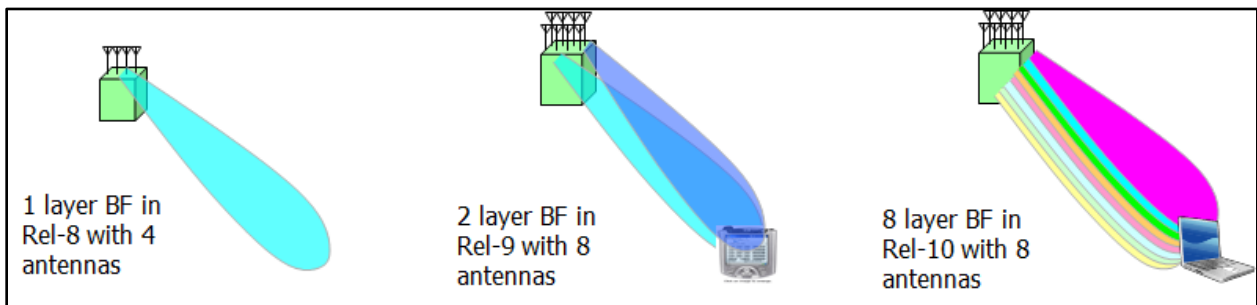
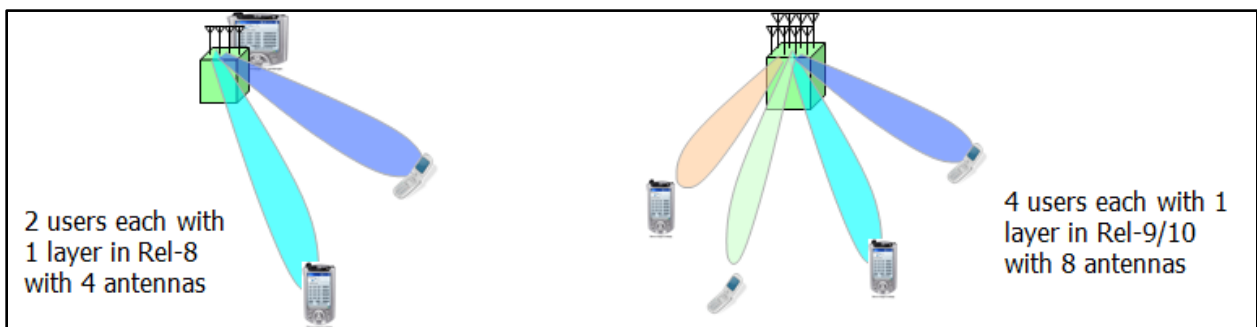

Figure 61 shows multi-user MIMO options across different releases. Release 8 supports two simultaneous users, each with one layer using four antennas, while Releases 9 and 10 support four simultaneous users, each with one layer.

**Figure 61: Multi-User MIMO<sup>124</sup>**



For four-antenna configurations at the base station, Release 12 improves throughput by adding a feedback mode, called mode 3-2, in which sub-band precoders and sub-band channel quality indicators (CQIs) are included in the UE's feedback to the eNodeB. Release 12 also adds a new codebook that further improves throughput.

<sup>123</sup> 4G Americas member contribution.

<sup>124</sup> 4G Americas member contribution.

As depicted in Figure 62 and Figure 63, compared with the Release 8 codebook, the new Release 12 codebook provides a 10% gain for both median and cell-edge throughputs. Compared with feedback mode 3-1, feedback mode 3-2 provides an 18% to 20% gain in median and cell-edge throughput. Jointly, the two methods provide a 28% to 30% gain.

**Figure 62: Median Throughput of Feedback Mode 3-2 and New Codebook.**<sup>125</sup>

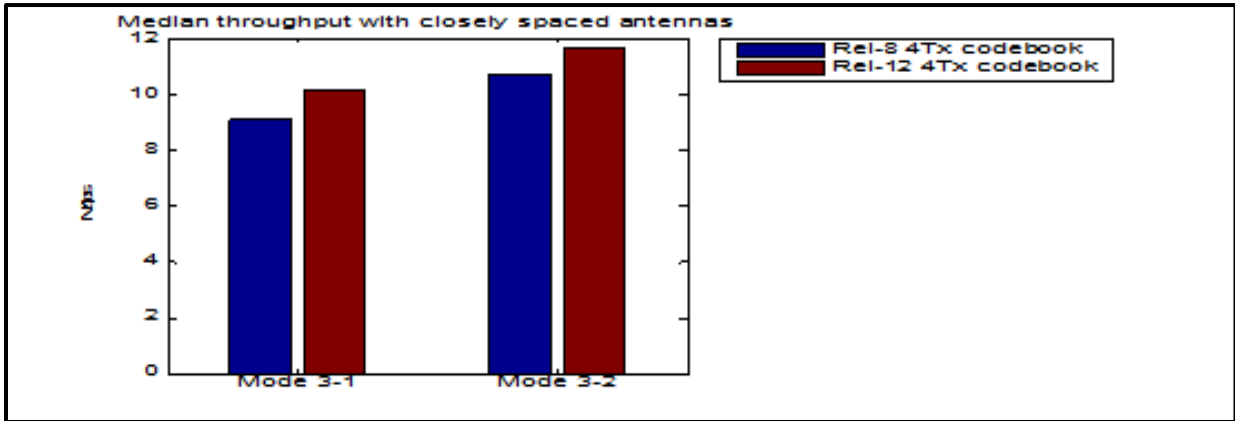

**Figure 63: Cell-Edge Throughput of Feedback Mode 3-2 and New Codebook.**<sup>126</sup>

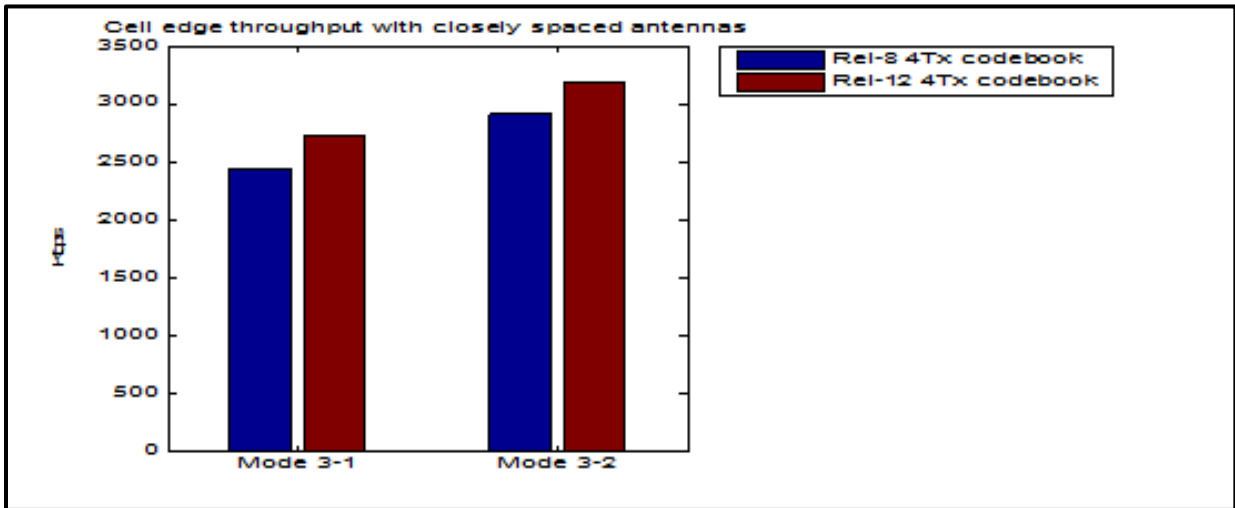

Release 12 also defines how Active Antenna Systems (AAS) can use multiple transceivers on an antenna array to dynamically adjust a radiation pattern.

Release 13 is likely to define full-dimension MIMO, which adds a large number of antenna elements, potentially as many as 64 elements.

<sup>125</sup> 4G Americas member contribution. Assumptions include: cellular layout of 19 sites hexagonal grid with three sectors per site and 500 meter inter-site distance; simulation case ITU uMa for macro; carrier frequency 2 GHz, deployment scenario A homogenous macro; SU-MIMO with maximum two layers per UE; proportional fair scheduler; and bursty traffic model.

<sup>126</sup> 4G Americas member contribution. Same assumptions as previous figure.

A practical consideration with antennas is that many towers today already support multiple operators, with tower companies having to manage interference placement, spectrum allocations, and wind and snow load. At higher frequencies, a single radome (antenna enclosure) can support 4X2 MIMO, but higher-order MIMO may prove impractical for many deployments.

5G systems operating at much higher frequencies will have an advantage since the antenna arrays will be much smaller due to the much smaller wavelengths.

### **Coordinated Multi Point (CoMP)**

Coordinated Multi Point (CoMP) is a communications technique that can improve coverage, cell-edge throughput, and/or system spectrum efficiency by reducing interference. This technique was thoroughly studied during the development of LTE-Advanced Release 10 and was standardized in Release 11.

CoMP coordinates transmissions at different cell sites, thereby achieving higher system capacity and improving cell-edge data rates.

The main principle of CoMP is that a UE at a cell edge location can receive signals from multiple transmission points, and/or its transmitted signal can be received by multiple reception points. Consequently, if these multiple transmission points coordinate their transmissions, the DL throughput performance and coverage can improve.

For the UL, signals from the UE received at multiple reception points can significantly improve the link performance. Techniques can range from simple interference avoidance methods, such as Coordinated Beam Switching (CBS) and Coordinated Beam Forming (CBF), to complex joint processing techniques that include Joint Transmission (JT), Joint Reception (JR), and Dynamic Point Selection (DPS).

CoMP architectures include inter-site CoMP, intra-site CoMP, as well as CoMP with distributed eNBs (i.e., an eNB with distributed remote radio heads). Figure 64 shows two possible levels of coordination.

**Figure 64: Different Coordination Levels for CoMP<sup>127</sup>**

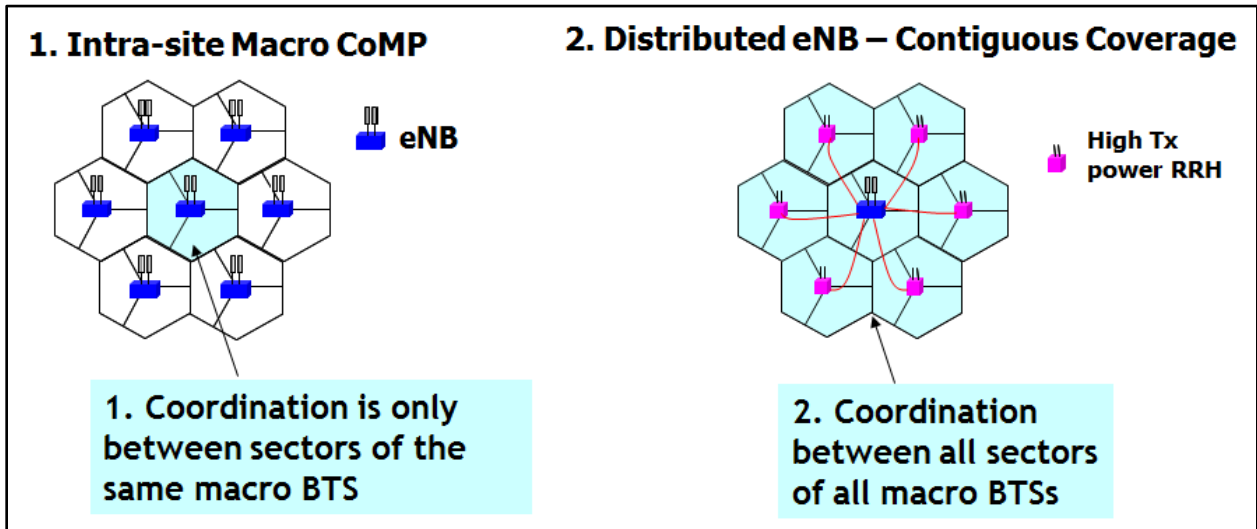

In one CoMP approach, called coordinated scheduling and shown in Figure 65, a single site transmits to the user, but with scheduling, including any associated beamforming, coordinated between the cells to reduce interference between the different cells and to increase the served user's signal strength. In joint transmission, another CoMP approach also shown in Figure 65, multiple sites transmit simultaneously to a single user. This approach can achieve higher performance than coordinated scheduling, but it has more stringent backhaul communications requirements. One simpler form of CoMP that will be available in Release 10, and then further developed in Release 11, is ICIC. Release 11 of LTE defines a common feedback and signaling framework for enhanced CoMP operation.

**Figure 65: Coordinated Scheduling/BF and Joint Processing CoMP Approaches<sup>128</sup>**

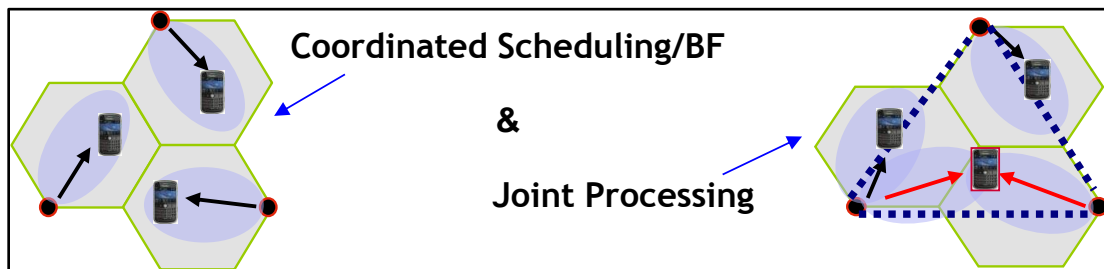

Release 11 also implements CoMP on the uplink, by which multiple base stations receive uplink transmissions and jointly process the signal, resulting in significant interference cancellation and improvements to spectral efficiency.

The performance gains expected from CoMP are under discussion in the industry. According to 3GPP document TR 36.819, for the case of resource utilization below 35%, CoMP may provide a 5.8% performance gain on the downlink for the mean user and a

<sup>127</sup> 4G Americas member contribution.

<sup>128</sup> 4G Americas member contribution.

17% gain for cell-edge users relative to HetNets without eICIC. For resource utilization of more than 35%, CoMP may provide a 17% mean gain and a 40% cell-edge gain.<sup>129</sup> CoMP can also be used in combination with eICIC for additional gains.

In the same 3GPP TR 36.819 document, 3GPP estimates the downlink CoMP gain in spectral efficiency, defined as average sector throughput for full buffer traffic using JT and 4x2 MU-MIMO as defined in R11, compared with 4x2 MU-MIMO based on R10, to be about 3% for intra-eNodeB CoMP. That gain drops to about 9% for inter-eNodeB CoMP in the case of no delay in the backhaul used to exchange information between eNodeBs. The corresponding gains in cell-edge user throughput are 20% and 31%, respectively.

When increasing the backhaul latency to a more realistic value of 10 msec for inter-eNodeB, spectral efficiency decreases to zero, and the cell edge gain decreases to 10%.

The gains for DL CoMP based on Coordinated Scheduling/Coordinated Beamforming (CS/CB) and intra-eNodeB are less than that provided by JT, with spectral efficiency at 1% and cell edge gains at 4%.

All of the above gains are for FDD networks with cross-polarized antennas at the eNodeBs. For TDD networks, the gains are higher by virtue of being able to invoke channel reciprocity and thus infer the DL channel directly from the UL channel. For example, for intra-eNodeB CoMP with JT 4x2 MU-MIMO, the respective gains in spectral efficiency and cell-edge throughput are 14% and 29%, respectively.

The gains for UL CoMP based on Joint Reception (JR) are greater than the DL gains. For intra-eNodeB CoMP, the average and cell-edge throughputs are increased to 22% and 40%, assuming two receive antenna paths with SU-MIMO. These respective gains increase to 31% and 66% for inter-eNodeB CoMP. In addition, UL CoMP does not require standardization and thus facilitates vendor implementation.

Uplink CoMP assists VoLTE because it improves cell-edge performance, making voice handover more reliable when traversing between cells. The benefit is analogous to CDMA soft handover; in both cases, the mobile device communicates with two sites simultaneously.

## **User Equipment Categories**

LTE specifications define categories of UE, which mainly determine the maximum throughputs of devices but also govern the number of downlink MIMO layers, as shown in Table 22.

Higher throughput capabilities are possible with 64 QAM and 256 QAM modulation. 3GPP is also defining Category 0 and Category M devices for M2M, as discussed in the section, "Internet of Things and Machine-to-Machine."

---

<sup>129</sup> 3GPP, *Coordinated Multi-Point Operation for LTE Physical Layer Aspects*, TR 36.819 v11.1.0, Tables 7.3.1.2-3 and 7.3.1.2-4, September 2011.

**Table 22: UE Categories<sup>130</sup>**

UE Category	Max DL Throughput	Maximum DL MIMO Layers	Maximum UL Throughput
1	10.3 Mbps	1	5.2 Mbps
2	51.0 Mbps	2	25.5 Mbps
3	102.0 Mbps	2	51.0 Mbps
4	150.8 Mbps	2	51.0 Mbps
5	299.6 Mbps	4	75.4 Mbps
6	301.5 Mbps	2 or 4	51.0 Mbps
7	301.5 Mbps	2 or 4	102.0 Mbps
8	2998.6 Mbps	8	1497.8 Mbps
9	452.3 Mbps	2 or 4	51.0 Mbps
10	452.3 Mbps	2 or 4	102.0 Mbps
11	603.0 Mbps	2 or 4	51.0 Mbps
12	603.0 Mbps	2 or 4	102.0 Mbps

### LTE-Advanced Relays

Another capability being planned for LTE-Advanced is relays, as shown in Figure 66. The idea is to relay frames at an intermediate node, resulting in much better in-building penetration, and with better signal quality, user rates will improve. Relay nodes can also improve cell-edge performance by making it easier to add picocells at strategic locations.

Relays provide a means for lowering deployment costs in initial deployments in which usage is relatively low. As usage increases and spectrum needs to be allocated to access only, operators can then employ alternate backhaul schemes.

---

<sup>130</sup> 3GPP, *Evolved Universal Terrestrial Radio Access (E-UTRA); User Equipment (UE) radio access capabilities*, Technical Specification 36.306 V12.4.0, March 2015.



**Figure 66: LTE-Advanced Relay<sup>131</sup>**

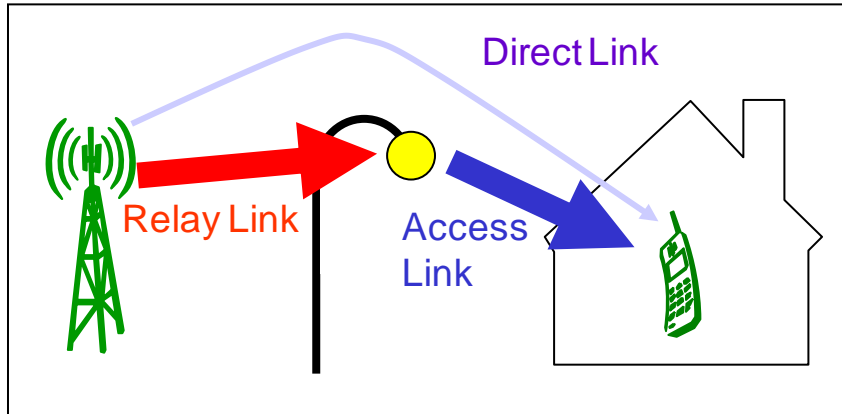

### Internet of Things and Machine-to-Machine

Anticipating huge growth in machine-to-machine communications, Release 11 added a Machine Type Communications (MTC) Interworking Function and Service Capability Server. Release 12 defines a category 0 device designed for low cost through a single antenna design and other simplifications.<sup>132</sup> Release 13 goes even further with a category M architecture that further reduces cost, improves range, and extends battery life.

**Table 23: Summary of IoT Features in LTE Devices**

Device Category	Category 3	Category 1	Category 0	Category M
<b>3GPP Release</b>	10	11	12	13
<b>Max. Data Rate Downlink</b>	100	10	1	0.2
<b>Max. Data Rate Uplink</b>	50	5	1	0.2
<b>Max. Bandwidth</b>	20 MHz	20 MHz	20 MHz	1.4 MHz
<b>Duplex</b>	Full	Full	Optional half-duplex	Optional half-duplex
<b>Max. Receive Antennas</b>	Two	Two	One	One
<b>Power</b>			Power Save	Power Save

<sup>131</sup> 4G Americas member contribution.

<sup>132</sup> 3GPP, *Access System for Ultra Low Complexity and Low Throughput Internet of Things based on Cellular*, GP-140301, May 2014.

Device Category	Category 3	Category 1	Category 0	Category M
			Mode	Mode
<b>Sleep</b>				Longer sleep cycles using Idle Discontinuous Reception (DRX)
<b>Coverage</b>				Extended through redundant transmissions and Single Frequency Multicast

### Proximity Services (Device-to-Device)

Release 12 defines a capability for devices to communicate directly with one another using LTE spectrum, a feature also called “operator-enabled proximity services.” With this capability, devices can autonomously discover nearby relevant devices and services in a battery-efficient manner. Devices broadcast their needs and services and can also passively identify services without user intervention.

Examples of applications include discovering friends and family (social matching), push advertising for relevant notifications, tourist bulletins, venue services, crime alerts, communications between public-safety personnel in emergency scenarios even when the rest of the network is unavailable, home automation, vehicle-to-vehicle communication, and detecting children leaving the vicinity of their homes. The service is designed to work during infrastructure failures, even in emergencies and natural disasters. As a new means of communicating, proximity services could result in innovative types of applications.

The LTE network performs configuration and authentication; however, communication can be either via the network or directly between devices. To minimize battery consumption, devices synchronously wake up for brief intervals to discover services. The impact on LTE network capacity is minimal.

As with other location-based services, operators and application developers will need to address privacy concerns.

### *LTE Throughput*

Table 24 summarizes LTE median and average throughput values for different LTE configurations.

**Table 24: LTE FDD User Throughputs Based on Simulation Analysis<sup>133</sup>**

Configuration	User Throughput, Mbps			
	Downlink (DL)		Uplink (UL)	
	Median	Average	Median	Average
LTE FDD: Low Band, 2x2 MIMO-DL, 1x2 SIMO-UL, 10+10 MHz, R8	8.6	10.9	4.5	5.0
LTE FDD: High Band, 4x2 MIMO-DL, 1x4 SIMO-UL, 10+10 MHz, R8	10.6	12.2	5.4	6.4
LTE FDD: High Band, 2x2 MIMO-DL, 1x2 SIMO UL, 20+20 MHz, R8	15.2	17.9	5.4	7.0
LTE FDD: High Band, 4x4 MIMO-DL, 1x4 SIMO UL, 20+20 MHz, R12	25.4	29.2	6.9	9.1

The simulation results represent a consensus view of 4G Americas members working on this white paper project. The goal of the analysis was to quantify LTE throughputs in realistic deployments. Simulation assumptions include:

- Traffic is FTP-like at a 50% load with a 75/25 mix of indoor/outdoor users.
- Throughput is at the medium-access control (MAC) protocol layer. (Application-layer throughputs may be 5 to 8 percent lower due to protocol overhead.)
- The 3GPP specification release numbers shown correspond to the infrastructure capability.
- The configuration in the first row corresponds to low-frequency band operation, representative of 700 MHz or cellular, while the remaining configurations assume high-frequency band operation, representative of PCS, AWS, or WCS. (Higher frequencies facilitate higher-order MIMO configurations and have wider radio channels available.)
- The downlink value for the first row corresponds to Release 8 device-receive capability (Minimum Mean Square Error [MMSE]), while the values in the other rows correspond to Release 11 device-receive capability (MMSE – Interference Rejection Combining [IRC]).
- The uplink value for the first row corresponds to a Maximal Ratio Combining (MRC) receiver at the eNodeB, while the remaining values correspond to an IRC receiver.

---

<sup>133</sup> 4G Americas member contribution. SIMO refers to Single Input Multiple Output antenna configuration, which in the uplink means one transmit antenna at the UE and multiple receive antennas at the eNodeB.

- Low-band operation assumes 1732 meter inter-site distance (ISD), while high-band operation assumes 500 meter ISD. The remaining simulation assumptions are listed in Table 25.

**Table 25: LTE FDD User Throughput Simulation Assumptions<sup>134</sup>**

Parameter	Value
Frequency	Low Band (LB): B17; High Band (HB): B30
Channel bandwidth	10 MHz, 20 MHz
System configuration	DL: 2x2, 4x2, and 4x4 Closed-Loop (CL) MIMO UL: 1x2 and 1x4 SIMO
Traffic type	FTP model 2: File size = 0.15 Mbyte, 1 second inter-arrival time, Load varied by changing number of users
Inter-Site Distance (ISD)	LB: 1732 m; HB: 500 m
Pathloss model	LB: HATA; HB: COST231 with correction
eNodeB transmit power	LB: 60 watts total; HB: 80 watts total
eNodeB antenna type	2 Tx = +45 degrees cross-pol (DIV-1X); 4 Tx = Closely separated pair of cross-pols (CLA-2X)
eNodeB antenna gain	LB: 14.8 dBi; HB: 17.5 dBi
eNodeB antenna pattern	Actual antenna patterns as used in RF planning tool
eNodeB Rx type	LB: MRC; HB: IRC
Downtilt	LB: 7 degrees; HB: 9 degrees
Penetration loss	75/25 mix of indoor/outdoor users LB: 12 dB for indoor users; HB: 22 dB for indoor users
Device speed	3 km/h all users
Channel model	Modified SCME-WINNER+, LB: Suburban Macro (SMa) scenario; HB: Urban Macro (UMa)
Device antenna type	+45 degrees cross-pol with built in correlation of 0.5
Device antenna gain and mismatch	LB: -5 dBi and 3 dB; HB: -3 dBi and 3 dB
Device body loss	3 dB for both bands
Device Rx type	MMSE, MMSE-IRC
Uplink power control	LB: alpha = 1, Po = -100 dBm; HB: alpha = 0.9, Po = -100 dBm
Scheduler	Proportional fair, frequency selective

The assumptions, emphasizing realistic deployments, do not necessarily match assumptions used by other organizations, such as 3GPP, so results may differ.

Additional insight into LTE performance under different configuration comes from a test performed on a cluster of cells in an LTE operator's network, comparing downlink

<sup>134</sup> 4G Americas member contribution.

performance of 4X2 MIMO against 2X2 MIMO, and uplink performance of 1X4 SIMO against 1X2 SIMO. The test employed LTE category 4 devices.<sup>135</sup>

These tests, which were performed in a 20+20 MHz cluster, show significant improvements in cell edge uplink and downlink throughput, in addition to an overall increase in uplink and downlink throughputs. Specific results include:

- ❑ A 100% increase in uplink throughput at the cell edge with 1X4 SIMO compared to 1x2 SIMO.
- ❑ A 40% increase in downlink throughput at the cell edge with 4x2 closed-loop MIMO compared to 2x2 open-loop MIMO
- ❑ A 50 to 75% increase in downlink throughput with closed loop MIMO compared to transmit diversity modes.
- ❑ Up to 6dB gains in uplink transmit power with 1X4 SIMO, which directly translates into UE battery savings.
- ❑ Peak speeds of 144 Mbps with 4X2 MIMO in the downlink and 47 Mbps with 1X4 SIMO in the uplink.

Another LTE operator's testing results for LTE in a TDD configuration, using 20 MHz channels, 3:2 DL to UL ratio, and category 3 devices, showed:

- ❑ Peak speeds of 55 Mbps.
- ❑ Typical speeds of 6 to 15 Mbps.<sup>136</sup>

Figure 67 shows the result of a drive test in a commercial LTE network with a 10 MHz downlink carrier demonstrating 20 Mbps to 50 Mbps throughput rates across much of the coverage area. Throughput rates would double with a 20+20 MHz configuration.

---

<sup>135</sup> 4G Americas member contribution.

<sup>136</sup> 4G Americas member contribution.

**Figure 67: Drive Test of Commercial European LTE Network (10+10 MHz)<sup>137</sup>**



---

<sup>137</sup> Ericsson contribution.

Figure 68 provides additional insight into LTE downlink throughput, showing Layer 1 throughput simulated at 10 MHz bandwidth using the Extended Vehicular A 3 km/hour channel model. The figure shows the increased performance obtained with the addition of different orders of MIMO. Note how throughput improves based on higher signal-to-noise ratio (SNR).

**Figure 68: LTE Throughput in Various Modes<sup>138</sup>**

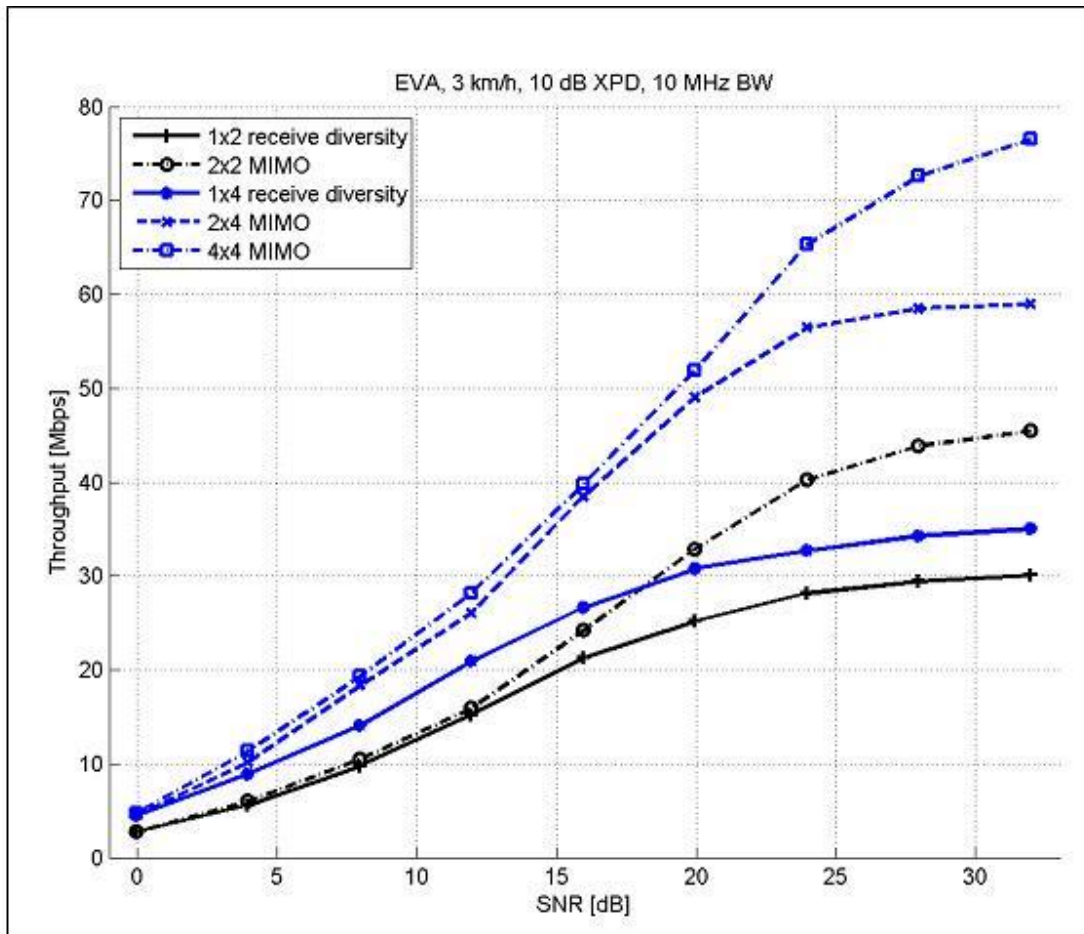

Actual throughput rates that users experience are lower than the peak rates and depend on a variety of factors:

- ❑ **RF Conditions and User Speed.** Peak rates depend on optimal conditions. Suboptimal conditions include being at the edge of the cell or moving at high speed, resulting in lower throughput.
- ❑ **Network Loading.** Like all wireless systems, throughput rates go down as more devices simultaneously use the network. Throughput degradation is linear.

<sup>138</sup> Jonas Karlsson, Mathias Riback, "Initial Field Performance Measurements of LTE," *Ericsson Review*, No. 3, 2008.

Figure 69 shows how dramatically throughput rates can vary by number of active users and radio conditions. The higher curves are for better radio conditions.

**Figure 69: LTE Actual Throughput Rates Based on Conditions<sup>139</sup>**

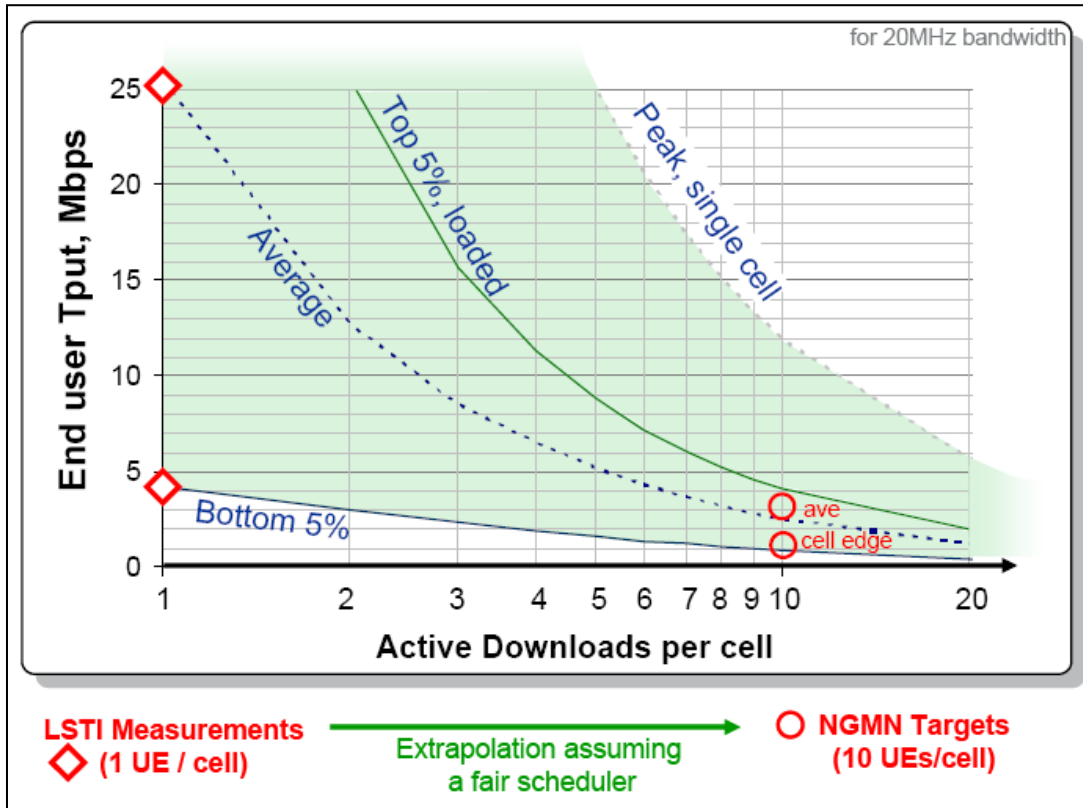

<sup>139</sup> LTE/SAE Trial Initiative, "Latest Results from the LSTI, Feb 2009," <http://www.lstiforum.org>.



## Heterogeneous Networks and Small Cells

A fundamental concept in the evolution of next-generation networks is the blending of multiple types of networks to create a “network of networks” characterized by:

- ❑ Variations in coverage areas, including femtocells (either enterprise femtos or home femtos, called HeNBs), picocells (also referred to as metro cells), and macro cells. Cell range can vary from 10 meters to 50 kilometers.
- ❑ Different frequency bands.
- ❑ Different technologies spanning Wi-Fi, 2G, 3G, and 4G.
- ❑ Relaying capability in which wireless links can serve as backhaul.

Figure 70 shows how user equipment might access different network layers.

**Figure 70: Load Balancing with Heterogeneous Networks.**<sup>140</sup>

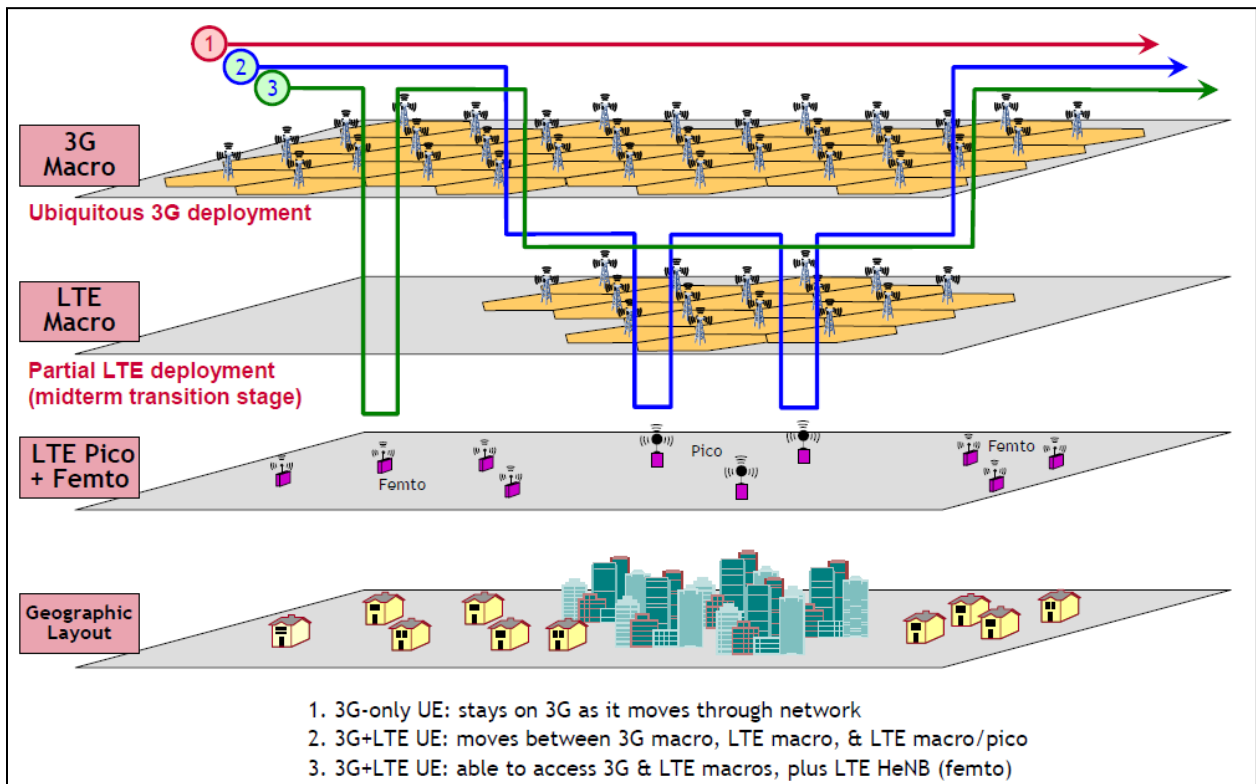

HetNets will allow significant capacity expansion in configurations in which operators can add picocells to coverage areas served by macrocells, particularly if there are hot spots with higher user densities.

<sup>140</sup> 4G Americas member contribution.

Small cells differentiate themselves from macrocells according to the parameters shown in Table 26.

**Table 26: Small Cell Vs. Macro Cell Parameters: Typical Values**

Parameter	Small Cell	Macro Cell
Transmission Power	24 dBm (0.25 W)	43 dBm (20 W)
Antenna Gain	2 dBi	15 dBi
Users	Tens	Hundreds
Mobility	30 km/hr.	350 km/hr.

Whether or not the small cell uses the same radio carriers as the macro cell involves multiple tradeoffs. In Figure 71 Scenario 1, the small cells and macro cell use different radio carriers, the two not interfering with each other. Although this configuration requires more spectrum, the small cells are able to cover larger areas than if they were deployed using the same radio carrier as the macro. This configuration supports medium-to-high penetration levels of small cells, allowing the network to reach huge capacity.

In Scenario 2, the small cells and macro cells use the same radio carrier, accommodating operators with more limited spectrum, but the network must manage interference using the techniques discussed below. Operators must carefully manage small-cell transmission power in this configuration.

**Figure 71: Scenarios for Radio Carriers in Small Cells**

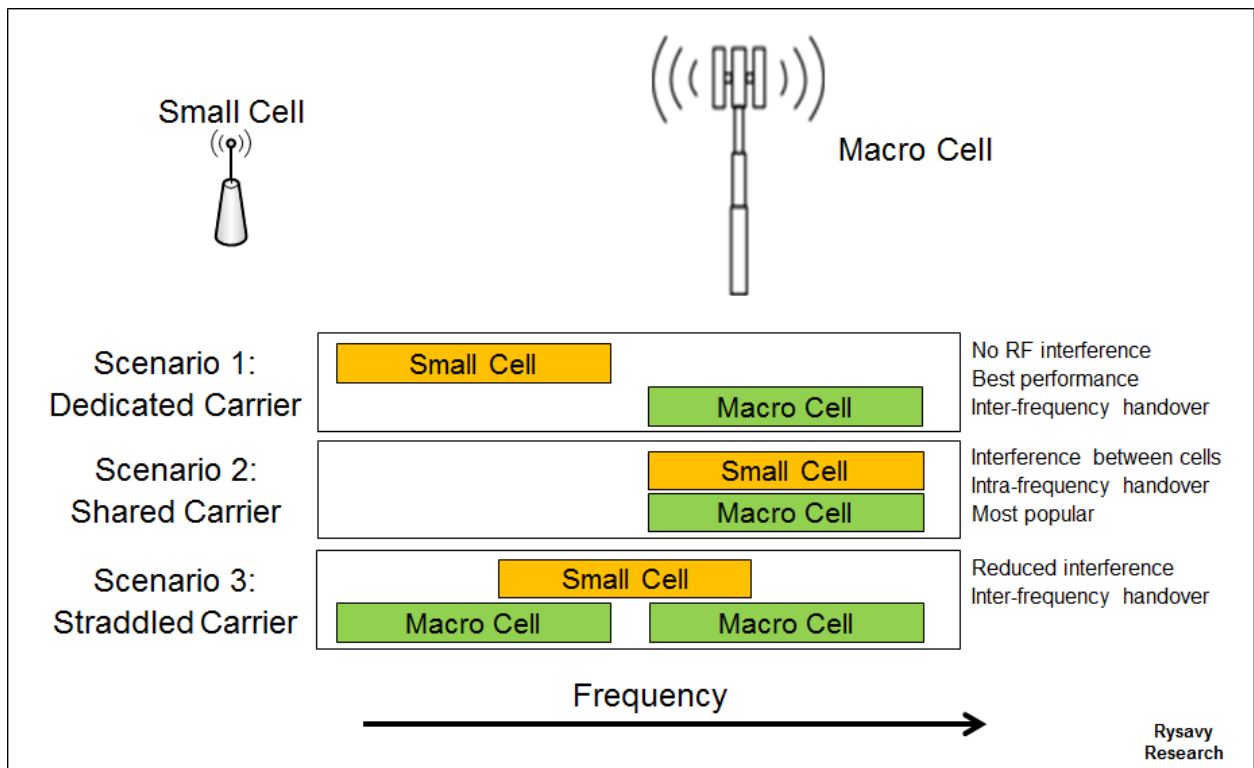

In Scenario 3, the small cells use a straddled radio carrier, accommodating operators with more spectrum, but the network still needs to manage interference using techniques discussed below. Compared with a shared carrier configuration, this configuration has benefits similar to dedicated carriers in terms of radio-parameter planning and reduced interference.

Figure 72 shows two different traffic distribution scenarios, with a uniform distribution of devices in the first and higher densities serviced by picocells in the second. The second scenario can result in significant capacity gains as well as improved user throughput.

**Figure 72: Different Traffic Distributions Scenarios**

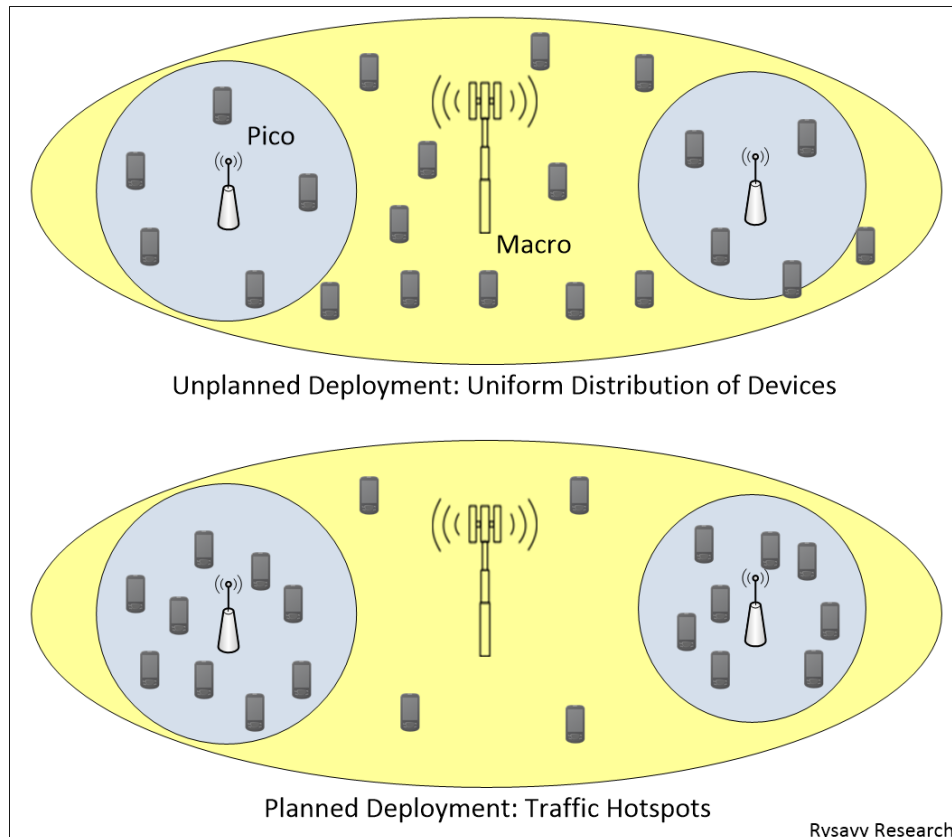

One vendor calculated expected HetNet gains assuming no eICIC, no picocell range extension, and no eICIC. For the case of four picocells without picocell range extension and uniform user distribution, the median-user-throughput gain compared with a macro-only configuration was 85%. For a similar case of four picocells but using a hotspot user distribution, the gain was much higher, 467%.<sup>141</sup> Additional gains will occur with picocell range extension.

<sup>141</sup> 4G Americas member contribution. Further assumes 2X1 W picocell transmit power, cell-edge placement (planned picocell deployment), 67% of all the users within 40m of the pico locations, and 3GPP Technical Report 36.814 adapted to 700 MHz.

Expected picocell gains rise proportionally to the number of picocells, so long as a sufficient number of UEs connect to the picocells.

Release 10 and Release 11 added enhanced support to manage the interference in the HetNet scenario in the time domain with Enhanced Inter-cell Interference Coordination (eICIC) and Further Enhanced Inter-cell Interference Coordination (feICIC), as well as in the frequency domain with carrier-aggregation-based ICIC.

HetNet capability keeps becoming more sophisticated through successive 3GPP releases as summarized in Table 27.

**Table 27: 3GPP HetNet Evolution**

3GPP Release	HetNet Feature
8	Initial SON capabilities, most for auto configuration. Initial intercell interference coordination (ICIC) available.
9	More mobility options (for example, handover between HeNBs), operator customer subscriber group (SCG) lists, load-balancing, coverage and capacity improvements.
10	An interface for HeNBs called Iurh that improves coordination and synchronization, LTE time domain eICIC. Carrier-aggregation-based ICIC also defined.
11	Improved eICIC, further mobility enhancements.

### Enhanced Inter-cell Interference Coordination

Significant challenges must be addressed in these heterogeneous networks. One is near-far effects, in which local small-cell signals can easily interfere with macro cells if they are using the same radio carriers.

Interference management is of particular concern in HetNets since, by design, coverage areas of small-coverage cells overlap with the macro cell. Beginning with Release 10, eICIC introduces an approach of almost-blank subframes by which subframe transmission can be muted to prevent interference. Figure 73 illustrates eICIC for the macro layer and pico layer coordination. If a UE is on a picocell but in a location where it is sensitive to interference from the macro layer, the macro layer can mute its transmission during specific frames when the pico layer is transmitting.

**Figure 73: Example of Enhanced Intercell Interference Coordination<sup>142</sup>**

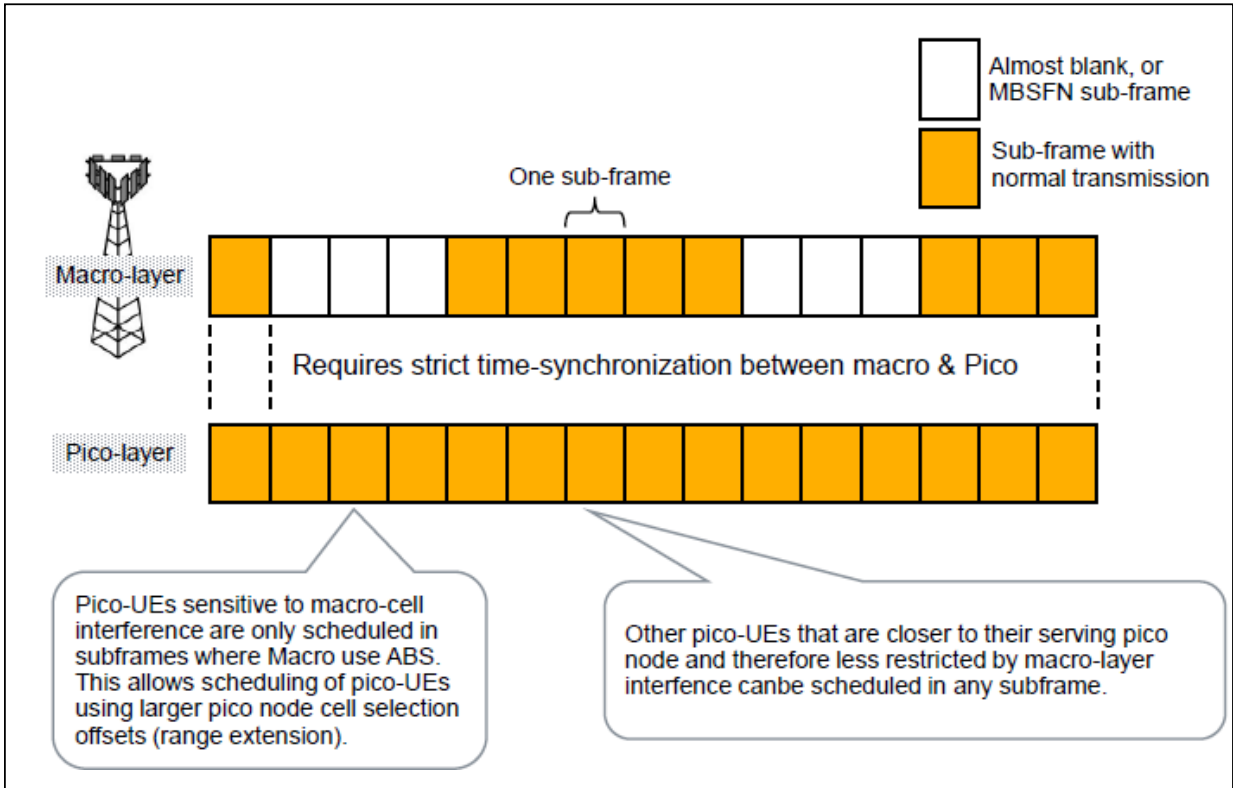

LTE can also combine eICIC with interference-cancellation-based devices to minimize the harmful effects of interference between picocells and macro cells.

Figure 74 shows one 4G America member's analysis of anticipated median throughput gains using picocells and Release 11 Further Enhanced ICIC.

<sup>142</sup> 4G Americas member contribution.

**Figure 74: Median Throughput Gains in Hotspot Scenarios<sup>143</sup>**

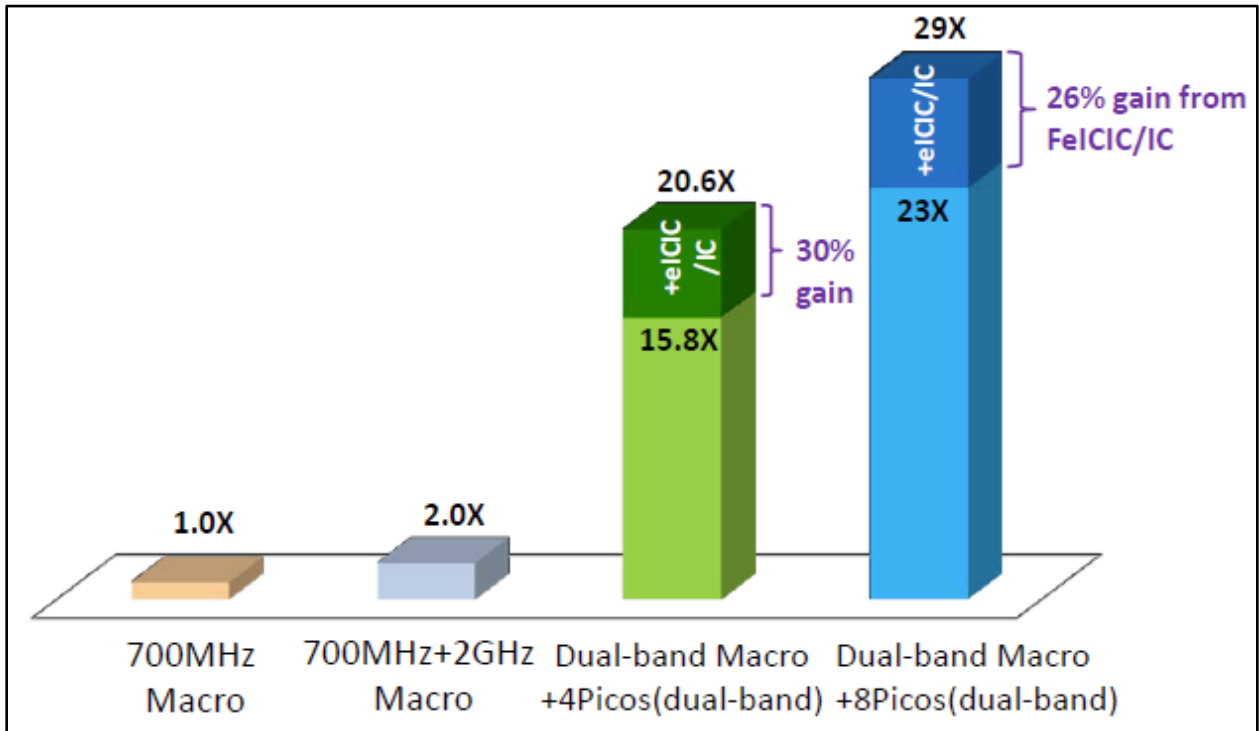

FeICIC is also beneficial in non-hotspot scenarios. In the case of a uniform distribution of picocells, this same 4G Americas member estimates a 130% gain from FeICIC for an eight picocell per macrocell scenario, increasing capacity from a factor of 3.3 for the picocells alone to a factor of 7.6 with the addition of FeICIC.<sup>144</sup>

Further insight is available from Figure 75, which shows 5 percentile and 50 percentile throughput with and without eICIC under different conditions of range extension and almost blanked subframes.

<sup>143</sup> 4G Americas member contribution. Assumes 3GPP evaluation methodology TR 36.814, carrier-aggregation UEs, macro ISD = 1732m, 700 MHz and 2GHz carrier frequency, full-buffer traffic, FDD 10+10 MHz per carrier, 6 degree antenna downtilt, 4 or 8 Picos and 30 UEs per Macro cell, hotspot distribution with 20 of 30 UEs near picos, PF scheduler, 2x2 MIMO, TU3 channel, NLOS, local partitioning algorithm.

<sup>144</sup> Assumes 3GPP evaluation methodology TR 36.814, macro ISD = 1732m, 700 MHz and 2GHz carrier frequency, full-buffer traffic, 6 degree antenna downtilt, 30 carrier-aggregation UEs per Macro cell, uniform random layout, PF scheduler, FDD, 10+10 MHz per carrier, 2x2 MIMO, TU3 channel, NLOS, local partitioning algorithm. Additional information is available at [ftp://ftp.3gpp.org/tsg\\_ran/WG1\\_RL1/TSGR1\\_66b/Docs/R1-113383.zip](ftp://ftp.3gpp.org/tsg_ran/WG1_RL1/TSGR1_66b/Docs/R1-113383.zip).

**Figure 75: User Throughput Performance With/Without eICIC for Dynamic Traffic vs. Average Offered Load per Macro-Cell Area<sup>145</sup>**

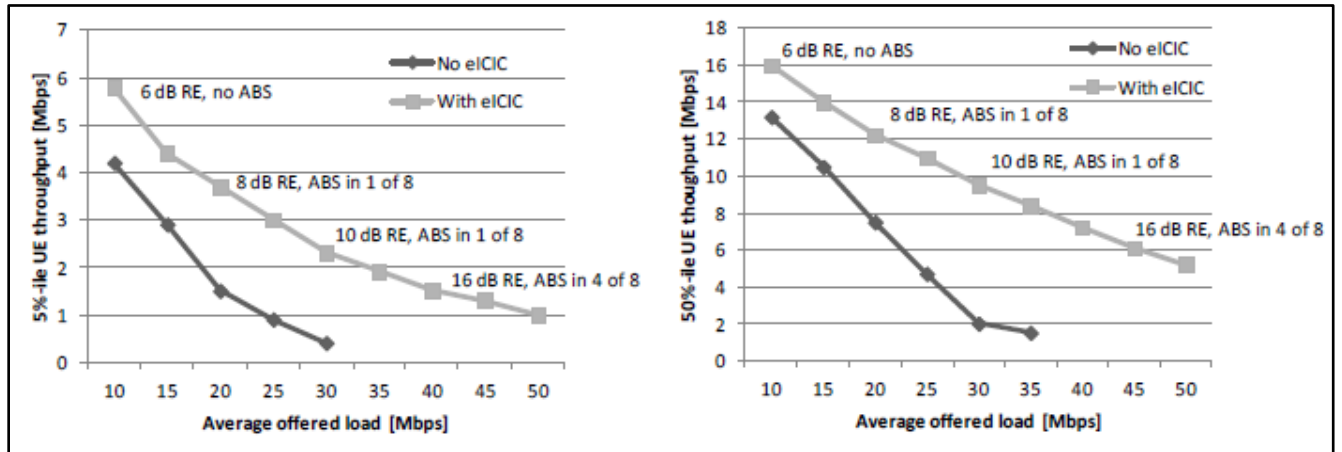

The muting of certain subframes in eICIC is dynamic and depends on identifying, on a per-user basis, whether an interfering cell’s signal exceeds a threshold relative to the serving cell signal. Coordinating muting among small cells can be complicated because a small cell can simultaneously be an interferer while serving a UE that is a victim of another cell. The network must therefore coordinate muting among multiple small cells.

Figure 76 below at left shows user throughput gains of time-domain interference relative to network load. Throughput gains are higher at higher network loads because of more active users and the higher likelihood of interference between the small cells.

Figure 76 below at right shows the maximum muting ratio, which increases with higher network load.

<sup>145</sup> 4G Americas member contribution. Assumes 3GPP evaluation methodology TR 36.814, 500 meter ISD, 4 picos per macro-cell area, Poisson call arrival, finite payload for each call, and termination of call upon successful delivery.

**Figure 76: Throughput Gain of Time-Domain Interference Coordination<sup>146</sup>**

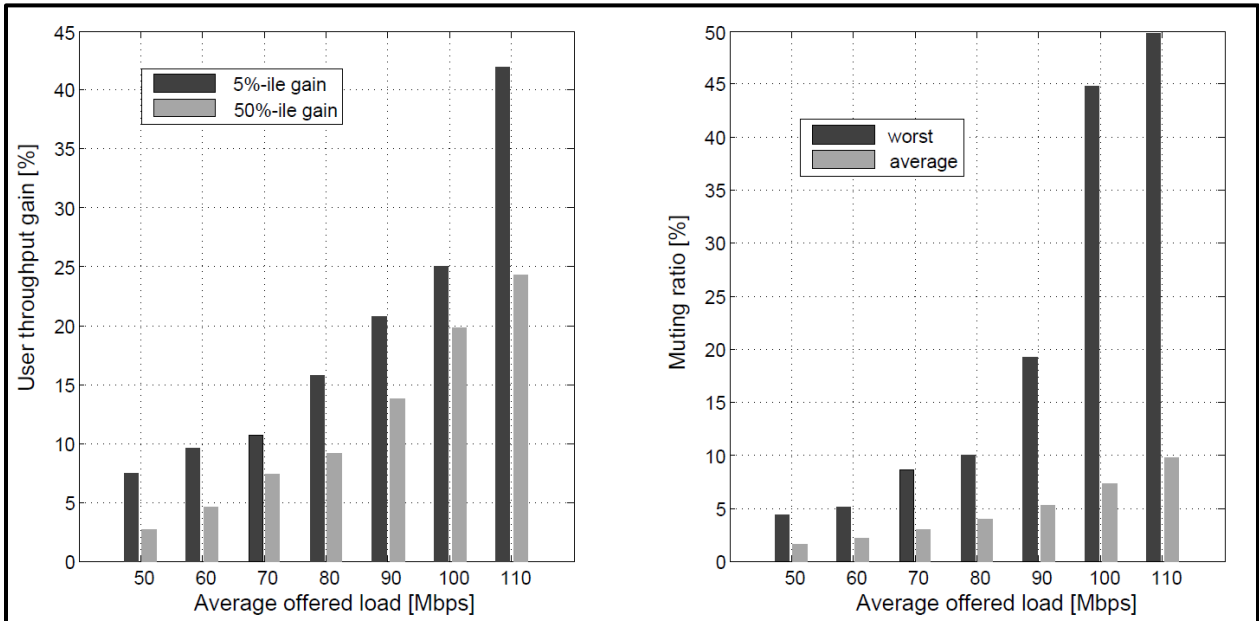

Another approach for addressing inter-layer interference cancellation in HetNets can come from carrier aggregation with no further additions or requirements and realizable with Release 10 LTE networks. Consider the scenario in Figure 77, in which both the macro eNB and the pico eNB are allocated two component carriers (namely CC1 and CC2). The idea is to create a “protected” component carrier for downlink control signals and critical information (Physical Downlink Control Channel, system information, and other control channels) while data can be conveniently scheduled on both component carriers through cross-carrier scheduling.

**Figure 77: Carrier-Aggregation Based ICIC<sup>147</sup>**

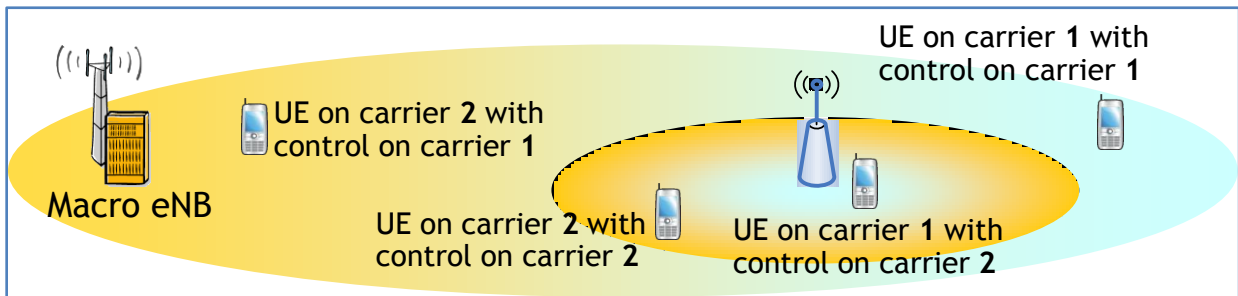

CC1 is the primary component carrier for the macro cell, while CC2 is the primary for the picocell; hence the protected carriers are CC1 for the macro cell and CC2 for the picocell.

<sup>146</sup> 4G Americas member contribution. Simulations based on 12 densely deployed small cells at 3.5 GHz and 3GPP Release 12 simulation assumptions in TR 36.842.

<sup>147</sup> 4G Americas member contribution.



The macro cell allocates a lower transmission power for its secondary CC in order to reduce interference to the picocell's primary component carrier. The network can schedule data on both the primary and secondary component carriers. In the figure, users in the cell-range expansion (CRE) zone can receive data via cross-carrier scheduling from the secondary CC at subcarrier frequencies on which interference from the other cell can be reduced if the cells exchange appropriate signaling over what is called an X2 interface. Users operating close to the eNodeBs can receive data from both component carriers as their interference levels will hopefully be lower. Therefore, a CA-capable receiver will enjoy the enhanced throughput capabilities of carrier aggregation, while simultaneously receiving extra protection for control and data channels at locations with potentially high inter-layer interference.

Thus, carrier aggregation can be a useful tool for deployment of heterogeneous networks without causing a loss of bandwidth. These solutions, however, do not scale well (in Release 10 systems) to small system bandwidths (say, 3+3 MHz or 1.4+1.4 MHz radio carriers) because control channels occupy a high percentage of total traffic. Additionally, interference between the cell reference signals (CRS) would also be significant.

### Dual Connectivity

A major enhancement in Release 12 is a UE being served at the same time by both a macro cell and a small cell operating at different carrier frequencies, a capability called dual connectivity and illustrated in Figure 78. Data first reaches the macro eNodeB and is split, with part of it transmitted from the macro and the balance sent via an X2 interface to the small cell for transmission to the UE.

**Figure 78: Dual Connectivity**<sup>148</sup>

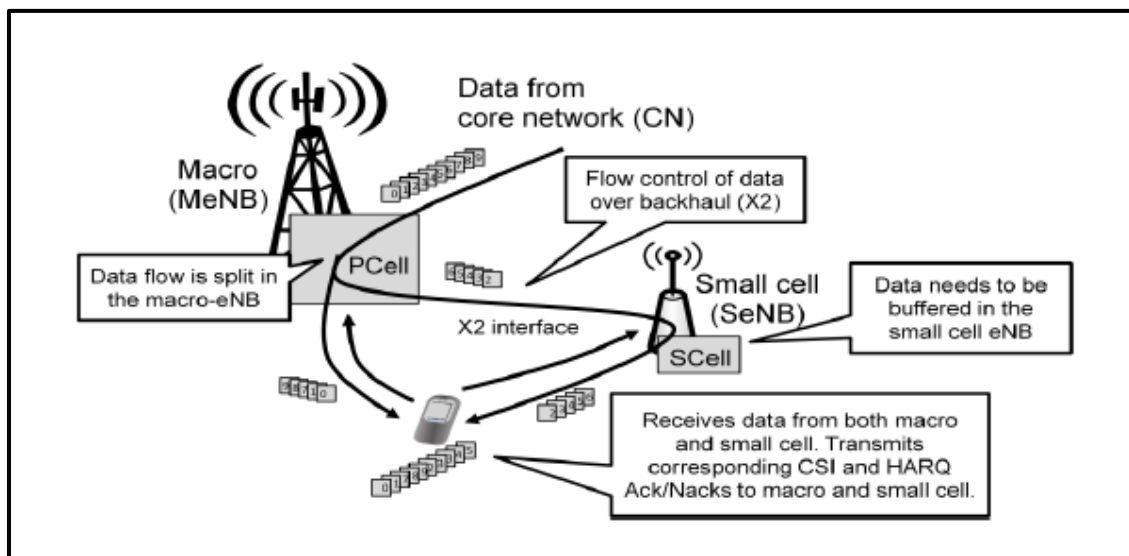
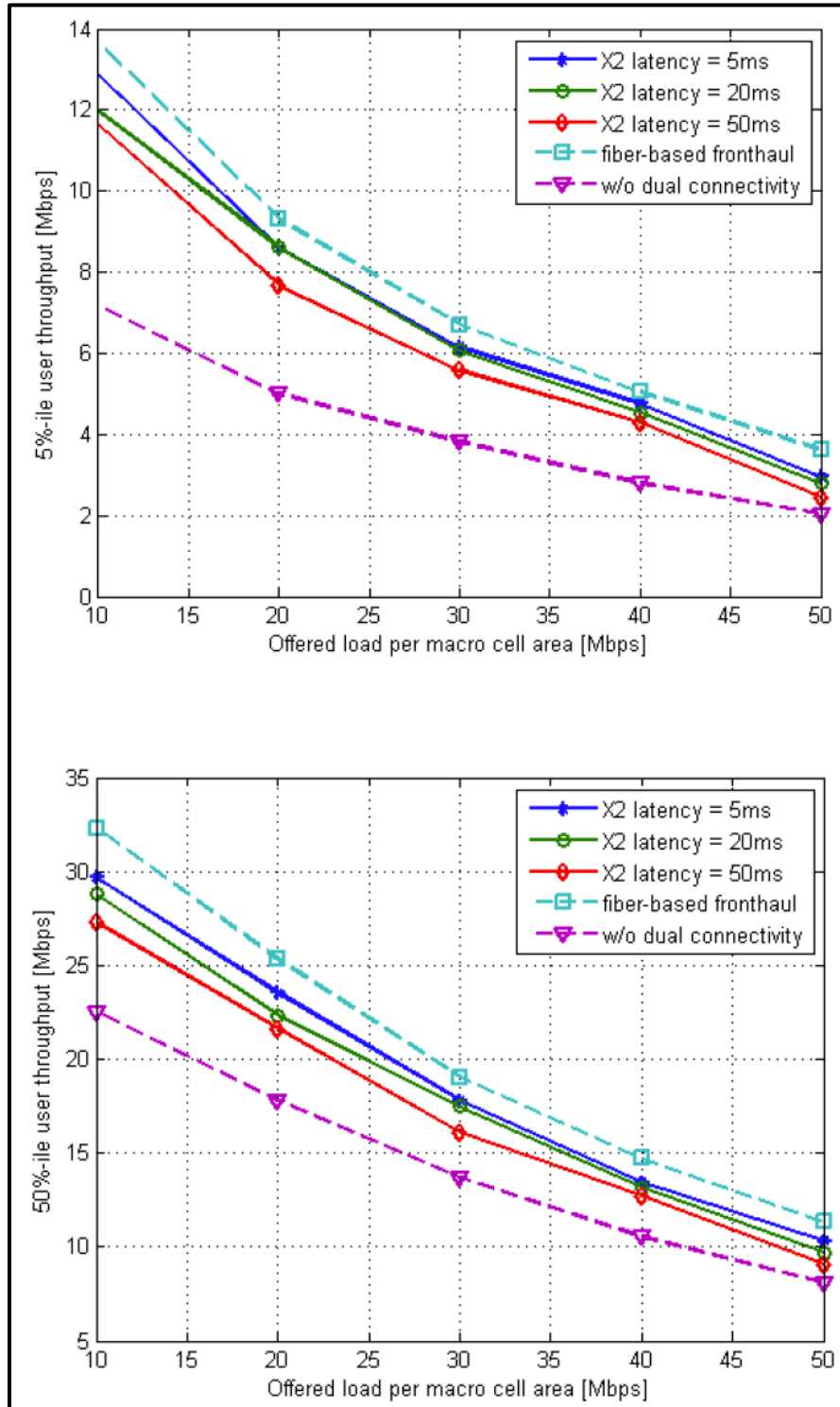

Figure 79 shows throughput gains of dual connectivity at 5 percentile and 50 percentile (median) levels relative to the load on the network and different degrees of latency in the X2 interface. Benefits are higher with lower network load and with lower X2 latency.

<sup>148</sup> Source: 4G Americas member contribution.

**Figure 79: Dual Connectivity User Throughput<sup>149</sup>**



<sup>149</sup> 4G Americas member contribution.

## ***Self-Organizing Networks (SON)***

As the number of base stations increase through denser deployments and through deployment of femtocells and picocells, manual configuration and maintenance of this infrastructure becomes impractical. With SON, base stations organize and configure themselves by communicating with one another and with the core network. SONs can also self-heal in failure situations.

3GPP began standardization of self-optimization and self-organization in Releases 8 and 9, a key goal being support of multi-vendor environments. Successive releases have augmented SON capabilities.

Features being defined in SON include:

- ❑ Automatic inventory;
- ❑ Automatic software download;
- ❑ Automatic neighbor relation;
- ❑ Automatic physical Cell ID assignment;
- ❑ Mobility robustness/handover optimization;
- ❑ Random access channel optimization;
- ❑ Load-balancing optimization;
- ❑ Inter-cell interference coordination (ICIC) management;
- ❑ Enhanced inter-cell interference coordination (eICIC) management;
- ❑ Coverage and capacity optimization;
- ❑ Cell outage detection and compensation;
- ❑ Self-healing functions;
- ❑ Minimization of drive testing;
- ❑ Energy savings; and
- ❑ Coordination among various SON functions.

3GPP categorizes SON as centralized, distributed, or hybrid, which is a combination of centralized and distributed approaches.

In a centralized architecture, SON algorithms operate on a central network management system or central SON server. In contrast, in a distributed approach, the SON algorithms operate at the eNBs, which make autonomous decisions based on local measurements as well as from other nearby eNBs received via an X2 interface that interconnects eNBs.

The distributed architecture permits faster and easier deployment but is not necessarily as efficient or as consistent in operation, especially in multi-vendor infrastructure deployments.

In a hybrid approach, shown in Figure 80, SON algorithms operate both at the eNB and at a central SON server, with the server supplying values of initial parameters, for example. The eNBs may then update and refine those parameters in response to local measurements.

The hybrid approach resolves deployment scenarios that cannot be resolved by dSON, for example, cases such as:

- ❑ No X2 interface between the eNBs.
- ❑ Multi-vendor deployment with different dSON algorithms.
- ❑ Multi-technology load balancing and user steering.

**Figure 80: Hybrid SON Architecture**<sup>150</sup>

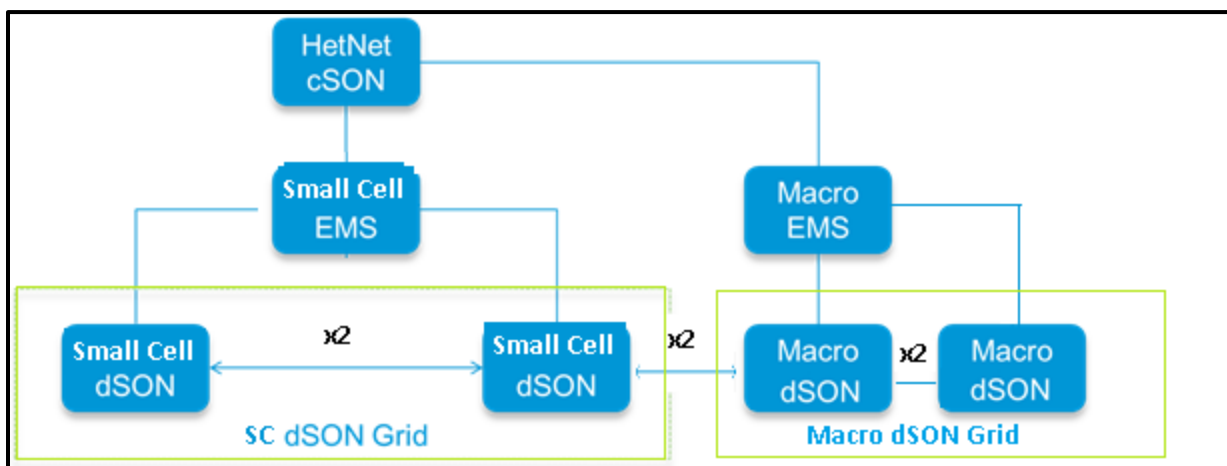

With increasing numbers of macro cells and small cells, interference opportunities increase as well. Optimizing power settings through intelligent power management algorithms is crucial for maximum efficiency with the least amount of interference, including pilot pollution. Pilot pollution can result in low data rates and ping-pong handovers due to channel fading. A hybrid SON approach is well suited for optimized power management.

## ***Evolved Packet Core (EPC)***

3GPP defined the Evolved Packet Core (EPC) in Release 8 as a framework for an evolution or migration of the network to a higher-data-rate, lower-latency, packet-optimized system that supports multiple radio-access technologies including LTE, as well as and legacy GSM/EDGE and UMTS/HSPA networks. EPC also integrates CDMA2000 networks and Wi-Fi.

EPC is optimized for all services to be delivered via IP in a manner that is as efficient as possible—through minimization of latency within the system, for example. It also provides service continuity across heterogeneous networks, which is important for LTE operators who must simultaneously support GSM-HSPA customers.

<sup>150</sup> 4G Americas member contribution.

One important performance-enhancing aspect of EPC is a flatter architecture. For packet flow, EPC includes two network elements, called Evolved Node B (eNodeB) and the Access Gateway (AGW). The eNodeB (base station) integrates the functions traditionally performed by the radio-network controller, which previously was a separate node controlling multiple Node Bs. Meanwhile, the AGW integrates the functions traditionally performed by the SGSN and GGSN. The AGW includes both control functions, handled through the Mobile Management Entity (MME), and user plane (data communications) functions. The user plane functions consist of two elements: A serving gateway that addresses 3GPP mobility and terminates eNodeB connections, and a Packet Data Network (PDN) gateway that addresses service requirements and also terminates access by non-3GPP networks. The MME serving gateway and PDN gateways can be collocated in the same physical node or distributed, based on vendor implementations and deployment scenarios.

The EPC architecture is similar to the HSPA One-Tunnel Architecture discussed in the "HSPA+" section, which allows for easy integration of HSPA networks to the EPC. Another architectural option is to reverse the topology, so that the EPC Access Gateway is located close to the RAN in a distributed fashion to reduce latency, while the MME is centrally located to minimize complexity and cost.

EPC uses IMS as a component. It also manages QoS across the whole system, an important enabler for voice and other multimedia-based services.

Figure 81 shows the EPC architecture.

**Figure 81: EPC Architecture**

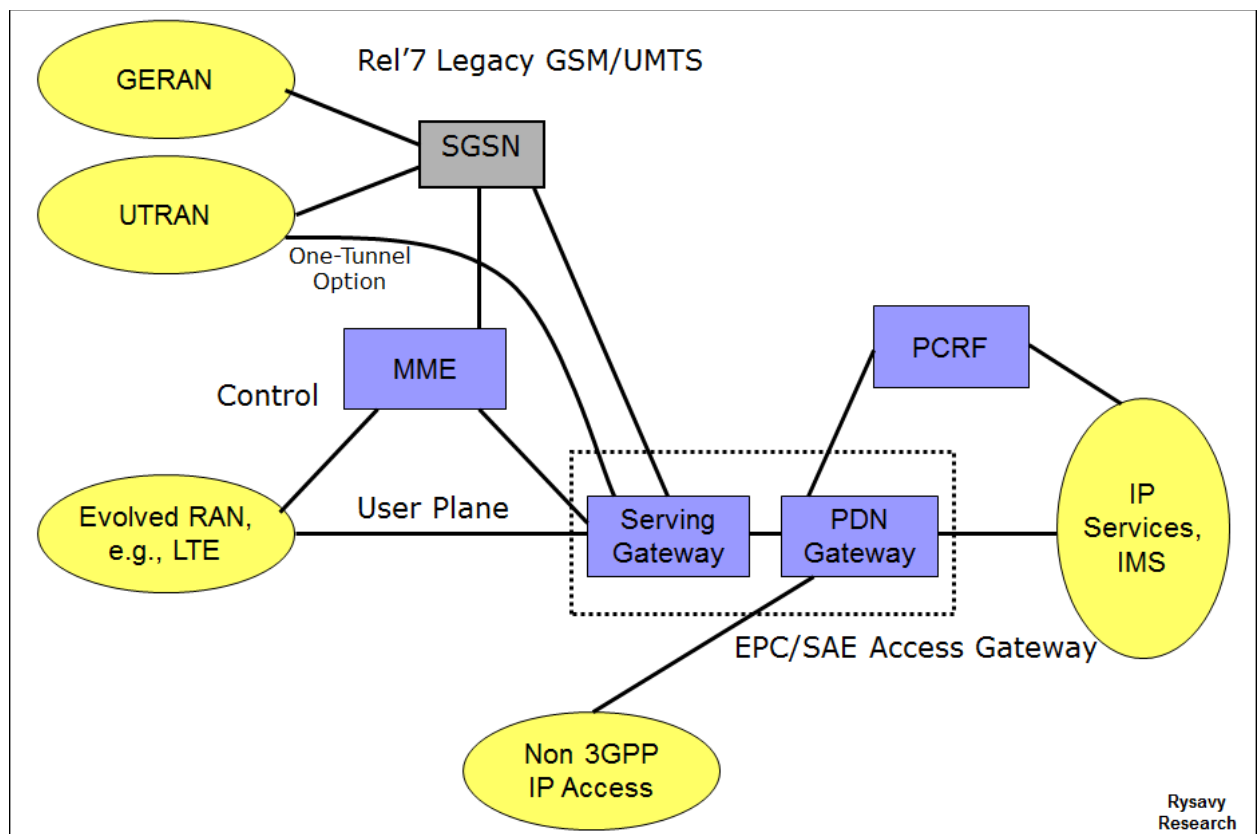

Elements of the EPC architecture include:

- ❑ Support for legacy GERAN and UTRAN networks connected via SGSN.
- ❑ Support for new radio-access networks such as LTE.
- ❑ Support for non-3GPP networks such as EV-DO and Wi-Fi. (See section below on Wi-Fi integration).
- ❑ The Serving Gateway that terminates the interface toward the 3GPP radio-access networks.
- ❑ The PDN gateway that controls IP data services, does routing, allocates IP addresses, enforces policy, and provides access for non-3GPP access networks.
- ❑ The MME that supports user equipment context and identity, as well as authenticating and authorizing users.
- ❑ The Policy Control and Charging Rules Function (PCRF) that manages QoS aspects.

QoS in EPS employs the QoS Class Identifier (QCI), a number denoting a set of transport characteristics (bearer with/without guaranteed bit rate, priority, packet delay budget, packet error loss rate) and used to infer nodes specific parameters that control packet forwarding treatment (such as scheduling weights, admission thresholds, queue management thresholds, or link-layer protocol configuration). The network maps each packet flow to a single QCI value (nine are defined in the Release 8 version of the specification) according to the level of service required by the application. Use of the QCI avoids the transmission of a full set of QoS-related parameters over the network interfaces and reduces the complexity of QoS negotiation. The QCI, together with Allocation-Retention Priority (ARP) and, if applicable, Guaranteed Bit Rate (GBR) and Maximum Bit Rate (MBR), determines the QoS associated to an EPS bearer. A mapping between EPS and pre-Release 8 QoS parameters permits interworking with legacy networks.

The QoS architecture in EPC enables a number of important capabilities for both operators and users:

- ❑ **VoIP support with IMS.** QoS is a crucial element for providing LTE/IMS voice service. (See section below on IMS).
- ❑ **Enhanced application performance.** Applications such as gaming or video can operate more reliably.
- ❑ **More flexible business models.** With flexible, policy-based charging control, operators and third-parties will be able to offer content in creative new ways. For example, an enhanced video stream to a user could be paid for by an advertiser.
- ❑ **Congestion control.** In congestion situations, certain traffic flows (bulk transfers, abusive users) can be throttled down to provide a better user experience for others.

Table 28 shows the nine QCI used by LTE.

**Table 28: LTE Quality of Service**

QCI	Resource Type	Priority	Delay Budget	Packet Loss	Examples
1	GBR (Guaranteed Bit Rate)	2	100 msec.	$10^{-2}$	Conversational voice
2	GBR	4	150 msec.	$10^{-3}$	Conversational video (live streaming)
3	GBR	3	50 msec.	$10^{-3}$	Real-time gaming
4	GBR	5	300 msec.	$10^{-6}$	Non-conversational video (buffered streaming)
5	Non-GBR	1	100 msec.	$10^{-6}$	IMS signaling
6	Non-GBR	6	300 msec.	$10^{-6}$	Video (buffered streaming), TCP Web, e-mail, and FTP.
7	Non-GBR	7	100 msec.	$10^{-3}$	Voice, video (live streaming), interactive gaming
8	Non-GBR	8	300 msec.	$10^{-6}$	Premium bearer for video (buffered streaming), TCP Web, e-mail, and FTP
9	Non-GBR	9	300 msec.	$10^{-6}$	Default bearer for video, TCP for non-privileged users

### ***Unlicensed Spectrum Integration***

3GPP has evolved its thinking on how best to integrate Wi-Fi with 3GPP networks. At the same time, the Wi-Fi Alliance and other groups have also addressed hotspot roaming, namely the ability to enable an account with one public Wi-Fi network provider to use the services of another provider that has a roaming arrangement with the first provider.

The multiple attempts to make Wi-Fi networks universally available have made for a confusing landscape of integration methods, which this section attempts to clarify. Most integration today is fairly loose, meaning that either a device communicates data via the cellular connection or via Wi-Fi. If via Wi-Fi, the connection is directly to the Internet and bypasses the operator core network. In addition, any automatic handover to hotspots occurs only between the operator cellular network and operator-controlled hotspots. The goals moving forward are to:

- ❑ Support roaming relationships so that users can automatically access Wi-Fi hotspots operated by other entities.
- ❑ Enable automatic connections so that users do not have to enter usernames and passwords. In most cases, this will mean authentication based on SIM credentials.
- ❑ Provide secure communications on the radio link as provided by the IEEE 802.11i standard.
- ❑ Allow policy-based mechanisms that define the rules by which devices connect to various Wi-Fi networks.
- ❑ Enable simultaneous connections to both cellular and Wi-Fi, with control over which applications use which connections.
- ❑ Support different types of Wi-Fi deployments, including third-party access points and carrier access points.

### **Release 6 I-WLAN**

3GPP Release 6 was the first release to offer the option of integrating Wi-Fi in a feature called Interworking WLAN (I-WLAN), using a separate IP address for each network type.

### **Release 8 Dual Stack Mobile IPv6 and Proxy Mobile IPv6**

3GPP Release 8 specified Wi-Fi integration with the EPC using two different approaches: host-based mobility with Dual Stack Mobile IPv6 (DSMIPv6) in the client, and network-based mobility with Proxy Mobile IPv6 (PMIPv6) using an intermediary node called an Enhanced Packet Data Gateway (ePDG).<sup>151</sup> This method is intended for untrusted (non-carrier-controlled) Wi-Fi networks.

### **Release 11 S2a-based Mobility over GTP**

Release 11, however, implements a new and advantageous approach as shown in Figure 82, one that eliminates the ePDG. Called S2a-based Mobility over GTP (SaMOG), a trusted WLAN access gateway connects to multiple 3GPP-compliant access points. Traffic can route directly to the Internet or traverse the packet core. This method is intended for trusted (carrier-controlled) Wi-Fi networks.

---

<sup>151</sup> 3GPP, *System Architecture Evolution (SAE); Security aspects of non-3GPP accesses*. TS 33.402.



**Figure 82: Release 11 SaMOG-based Wi-Fi Integration**

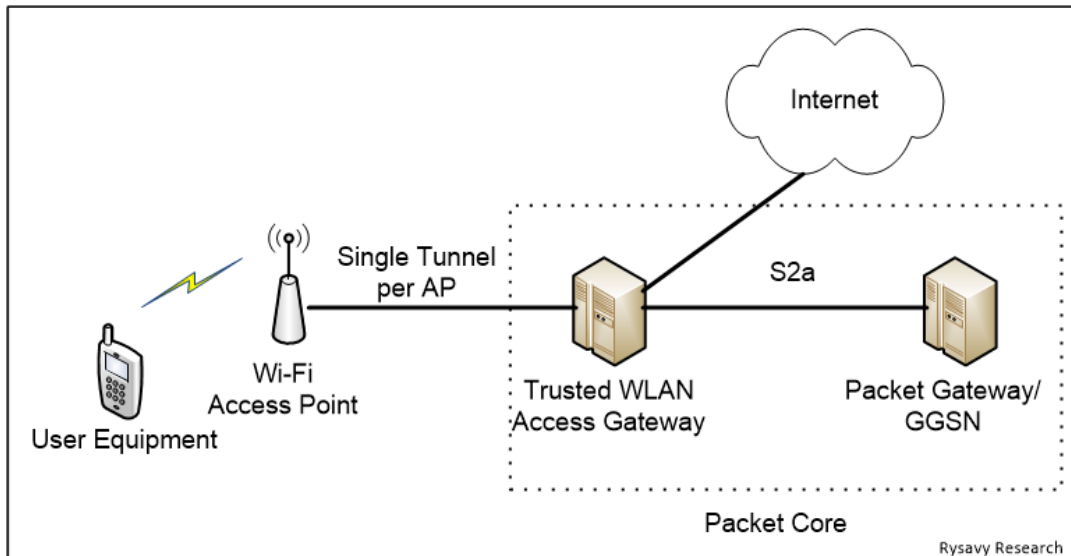

Release 12 improves SaMOG capabilities in Enhanced SaMOG (eSaMOG), in which UEs can:

- ❑ Request the connectivity type
- ❑ Indicate the Access Point Name (APN) to establish PDN connectivity
- ❑ Request to hand over an existing PDN connection
- ❑ Establish multiple PDN connections in parallel over the WLAN
- ❑ Establish a non-seamless WLAN offload connection in parallel to a Packet Data Network connection over WLAN.

## LTE-U, LTE License Assisted Access, LTE Wi-Fi Aggregation

As introduced in the main part of this paper in the discussion of integration of unlicensed spectrum, additional methods for integrating unlicensed spectrum include LTE-U, LTE Licensed Assisted Access (LAA), and LTE Wi-Fi Aggregation (LWA).

Table 29 summarizes the technical aspects of these approaches.

**Table 29: LTE-U, LTE-LAA, LWA Integration Approaches**

Approach	Radio	Co-Existence	Bands	Downlink/Uplink	Standards
LTE-U	LTE	Duty cycle	5 GHz	DL	None
LTE-LAA	LTE	Listen Before Talk	5 GHz, 3.5 GHz under consideration	DL <sup>152</sup>	3GPP Release 13
LWA	Wi-Fi	802.11	2.4 GHz, 5 GHz	DL and UL	3GPP Release 13

## Multipath TCP

A new method for potentially integrating Wi-Fi and 3GPP networks is based on work by the Internet Engineering Taskforce (IETF). Called Multipath TCP, the approach allows a TCP connection to occur simultaneously over two different paths. The advantages of this approach include higher speeds by aggregating links and not requiring any special provisions for link-layer handovers.

The IETF has published an experimental specification, *Request for Comments 6824: CP Extensions for Multipath Operation with Multiple Addresses*, which explains this approach.

## ANDSF

Another relevant specification is 3GPP Access Network Discovery and Selection Function (ANDSF), which provides mechanisms by which mobile devices can know where, when, and how to connect to non-3GPP access networks, such as Wi-Fi.<sup>153</sup> ANDSF operates independently of SaMOG or other ways that Wi-Fi networks might be connected.

ANDSF functionality increases with successive 3GPP versions, as summarized in Table 30.

---

<sup>152</sup> Uplink under consideration for 3GPP Release 14.

<sup>153</sup> 3GPP, *Architecture enhancements for non-3GPP accesses, Technical Specification 23.402*.

**Table 30: ANDSF Policy Management Objects and 3GPP Releases<sup>154</sup>**

ANDSF Policy Type	Policy Rule & Management Object	Release 8, 9	Release 10, 11	Release 12
Inter-System Mobility Policy (ISMP)	Policy, Rule priority, Prioritized Access, Validity Area (3G,4G, Wi-Fi, Geo), PLMN, Time-of-Day	X	X	X
Discovery Info	Access Network Type, Access Network Area (3G, 4G, Wi-Fi, Geo), Access Network Reference	X	X	X
UE Location	3GPP, 3GPP2, WiMAX, Wi-Fi network ID, Geo Location, PLMN	X	X	X
Inter-System Routing Policy (ISRP)	Flow Based routing, Service Based routing, Non-Seamless Offload, Roaming, PLMN, Routing Criteria, Time-of-Day, Routing rule		X	X
UE Profile	Device app/OS capability		X	X
Inter-APN Routing Policy (IARP)	Inter-APN routing over IP interface (in progress)			X
WLAN Selection Policy	Operator defined WLAN selection policy			X
Rule Selection Information	VPLMN with preferred WLAN roaming			X
Home Operator Preference	Home SP preference for S2a PDN session			X

### Bidirectional Offloading Challenges

Eventually, operators will be able to closely manage user mobile broadband and Wi-Fi connections, dynamically selecting a particular network for a user based on real-time changes in loads and application requirements. Work is occurring in Release 12 to define parameters that would control switching from LTE to Wi-Fi or from Wi-Fi to LTE.<sup>155</sup>

Bidirectional offloading, however, creates various challenges, as shown in Figure 83 and discussed below.

<sup>154</sup> Courtesy Smith Micro Software, 2014. <http://www.smithmicro.com>.

<sup>155</sup> 3GPP, *Study on Wireless Local Area Network (WLAN) - 3GPP radio interworking (Release 12)*, TR 37.834.

**Figure 83: Bidirectional-Offloading Challenges**

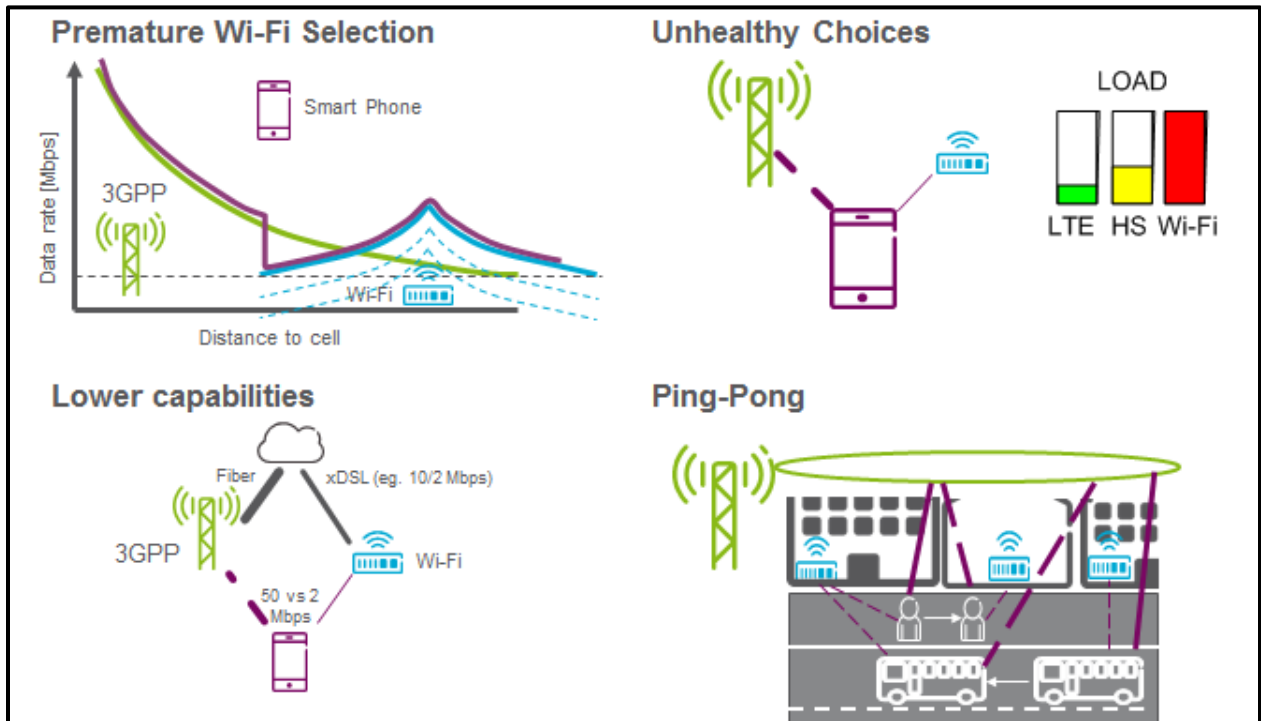

1. **Premature Wi-Fi Selection.** As Wi-Fi-capable devices move into Wi-Fi coverage, they can prematurely reselect to Wi-Fi without comparative evaluation of existing cellular and incoming Wi-Fi capabilities, possibly resulting in the degradation of the end user experience. Real-time throughput-based traffic steering can mitigate this effect.
2. **Unhealthy choices.** In a mixed network of LTE, HSPA, and Wi-Fi, reselection can occur due to a strong Wi-Fi network signal even though the network is under heavy load. The resulting “unhealthy” choice degrades the end user experience because the performance on the cell edge of a lightly loaded cellular network may be superior to that of the heavily loaded Wi-Fi network. Real-time load-based traffic steering can be beneficial in this scenario.
3. **Lower capabilities.** In some cases, selection to a Wi-Fi network may result in reduced performance even if it offers a strong signal because of other factors, such as lower-bandwidth backhaul. Evaluation of criteria beyond wireless capabilities prior to access selection can improve this circumstance.
4. **Ping-Pong.** Ping-ponging between Wi-Fi and cellular, especially if both offer similar signal strengths, can also degrade the user experience. Hysteresis approaches, similar to those used in cellular inter-radio transfer, can better manage transfer between Wi-Fi and cellular accesses.

3GPP RAN2 is discussing real-time or near-real-time methods to address the challenges discussed above.

## Other Integration Technologies (SIPTO, LIPA, IFOM, MAPCON)

Release 10 defines additional options for Wi-Fi integration, including Selected IP Traffic Offload (SIPTO), Local IP Access (LIPA), Multi-Access PDN Connectivity (MAPCON), and IP Flow and Seamless Offload (IFOM).

SIPTO is mostly a mechanism to offload traffic that does not need to flow through the core, such as Internet-destined traffic. SIPTO can operate on a home femtocell, or it can operate in the macro network.

Local IP Access (LIPA) provides access to local networks, useful with femtocells that normally route all traffic back to the operator network. With LIPA, the UE in a home environment can access local printers, scanners, file servers, media servers, and other resources.

IFOM, as shown in Figure 84, enables simultaneous cellular and Wi-Fi connections, with different traffic flowing over the different connections. A Netflix movie could stream over Wi-Fi, while a VoIP call might flow over the cellular-data connection. IFOM requires the UE to implement Dual Stack Mobile IPv6 (DSMIPv6).

**Figure 84: 3GPP IP Flow and Seamless Mobility**

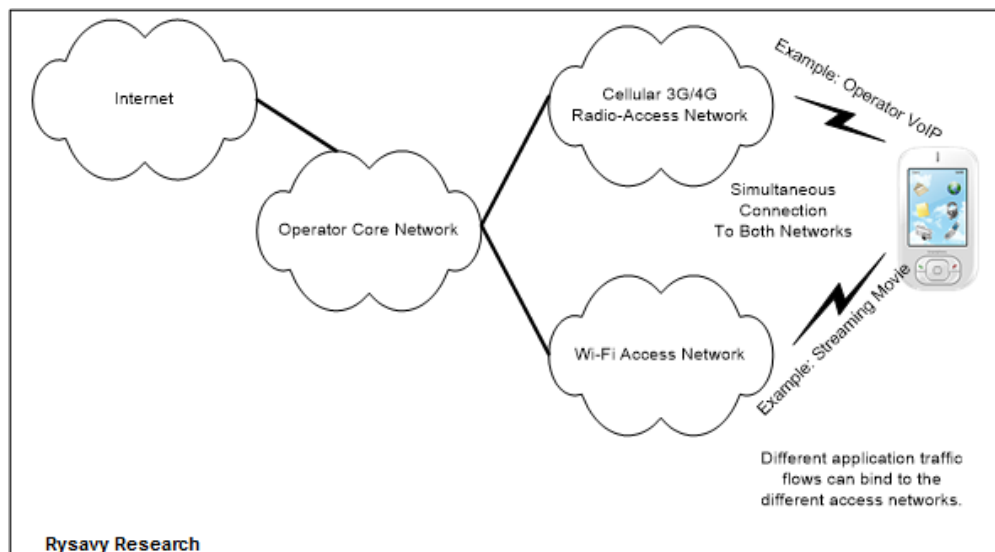

Similar to IFOM, Release 10 feature MAPCON allows multiple simultaneous PDN connections (each with a separate APN), such as Wi-Fi and 3GPP radio access. The UE uses separate IP addresses for each connection but does not need Dual Stack Mobile IPv6 (DSMIPv6).

## Hotspot 2.0

Separately from 3GPP, the Wi-Fi alliance has developed the Hotspot 2.0 specifications. Based on the IEEE 802.11u standard, user devices can determine what roaming relationships an access point supports and can then securely connect to the Wi-Fi network using one of these roaming arrangements, as shown in Figure 85. Hotspot 2.0 authentication is based on the Extended Authentication Protocol (EAP) using SIM credentials. There are plans to enhance the Hotspot 2.0 protocols in Phase 2, which will define online signup to enable non-SIM-based devices to easily and securely register for services. The Wi-Fi alliance began a Hotspot 2.0 certification process for devices and

access points in June 2012 and will use the designation "Wi-Fi Certified Passpoint" for compliant devices.

**Figure 85: Hotspot 2.0 Connection Procedure**

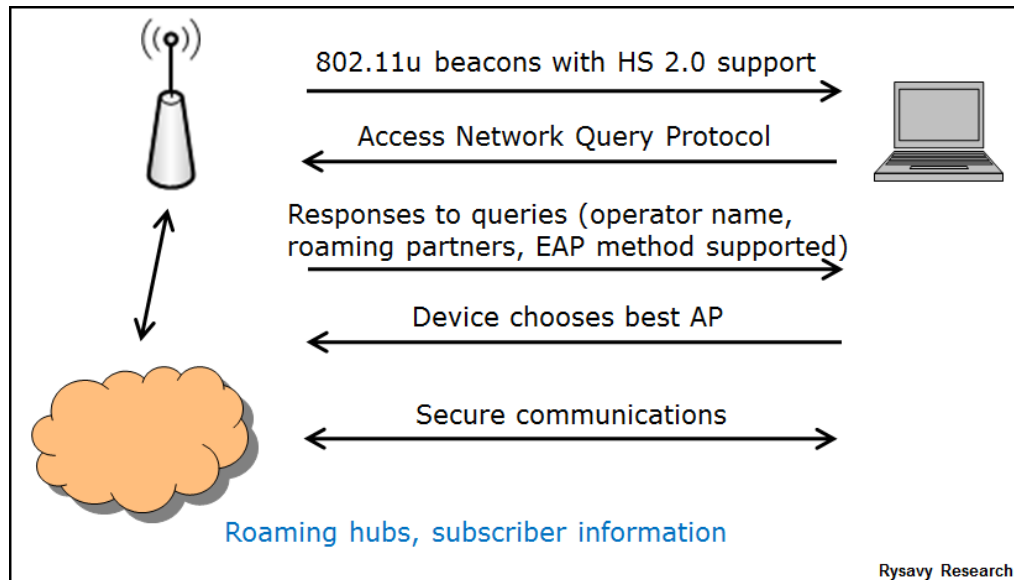

Release 2 of Passpoint, available in 2014, adds an important feature, immediate account provisioning, which facilitates a user establishing an account at the point of access. The new version also provides for policies to be downloaded from the network operator; these policies control network selection priorities when multiple networks are available.

## ***IP Multimedia Subsystem (IMS)***

IP Multimedia Subsystem (IMS) is a service platform for IP multimedia applications: video sharing, PoC, VoIP, streaming video, interactive gaming, and others. IMS by itself does not provide all these applications. Rather, it provides a framework of application servers, subscriber databases, and gateways to make them possible. The exact services will depend on cellular operators and the application developers that make these applications available to operators.

The core networking protocol used within IMS is Session Initiation Protocol (SIP), which includes the companion Session Description Protocol (SDP) used to convey configuration information such as supported voice codecs. Other protocols include Real Time Transport Protocol (RTP) and Real Time Streaming Protocol (RTSP) for transporting actual sessions. The QoS mechanisms in UMTS will be an important component of some IMS applications.

Although originally specified by 3GPP, numerous other organizations around the world are supporting IMS. These include the IETF, which specifies key protocols such as SIP, and the Open Mobile Alliance, which specifies end-to-end, service-layer applications. Other organizations supporting IMS include the GSMA, ETSI, CableLabs, 3GPP2, The Parlay Group, the ITU, ANSI, the Telecoms and Internet Converged Services and Protocols for Advanced Networks (TISPAN), and the Java Community Process (JCP).

IMS is relatively independent of the radio-access network and can, and likely will, be used by other radio-access networks or wireline networks. Other applications include picture and video sharing that occur in parallel with voice communications. Operators

looking to roll out VoIP over networks will use IMS. For example, VoLTE depends on IMS infrastructure. 3GPP initially introduced IMS in Release 5 and has enhanced it in each subsequent specification release.

As shown in Figure 86, IMS operates just outside the packet core.

**Figure 86: IP Multimedia Subsystem**

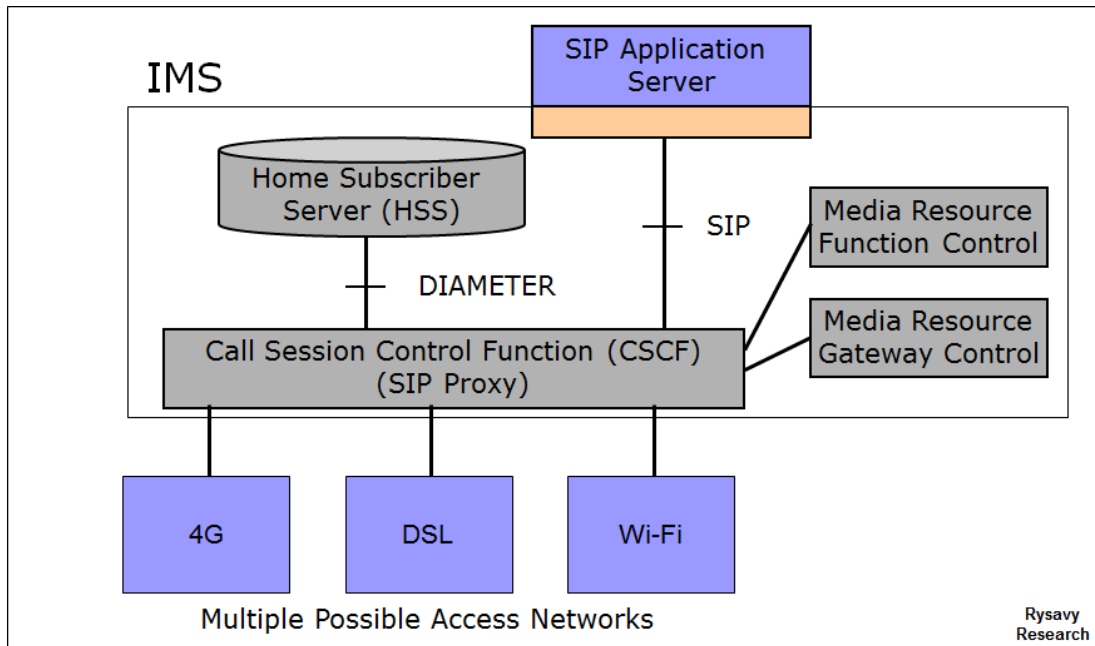

The benefits of using IMS include handling all communication in the packet domain, tighter integration with the Internet, and a lower cost infrastructure based on IP building blocks for both voice and data services.

IMS applications can reside either in the operator’s network or in third-party networks including those of enterprises. By managing services and applications centrally—and independently of the access network—IMS can enable network convergence. This allows operators to offer common services across 3G, Wi-Fi, and wireline networks.

Service Continuity, defined in Release 8, provided for a user’s entire session to continue seamlessly as the user moves from one access network to another. Release 9 expanded this concept to allow sessions to move across different device types. For example, the user could transfer a video call in mid-session from a mobile phone to a large-screen TV, assuming both have an IMS appearance in the network.

Release 8 introduced the IMS Centralized Services (ICS) feature, which allows for IMS-controlled voice features to use either packet-switched or circuit-switched access.

## **Cloud Radio-Access Network (RAN) and Network Virtualization**

Still in the early stages of development, cloud RAN (C-RAN) is a distributed architecture in which multiple remote radio heads connect to a “cloud” that consists of a farm of baseband processing nodes. This approach can improve centralized processing, as is needed for CoMP, centralized scheduling, and multiframe, without the need to exchange

information among many access nodes. The performance of both LTE and HSPA technologies could be enhanced by the application of cloud RAN architectures. The term “fronthauling” has been used to describe the transport of “raw” radio signals to central processing locations.

This architecture, shown in Figure 87, comes at the cost of requiring high-speed, low-latency backhaul links between these radio heads and the central controller. One vendor states that carrying 10+10 MHz of LTE with 2X2 MIMO requires 2.5 Gbps of bandwidth and imposes less than 0.1 msec of delay.<sup>156</sup> A standard called Common Public Radio Interface (CPRI) addresses generic formats and protocols for such a high-speed link. ETSI has also developed the Open Radio Equipment Interface (ORI). The feasibility of cloud RAN depends to a large extent on the cost and availability of fiber links between the remote radio heads and the centralized baseband processing location.

**Figure 87: Potential Cloud RAN Approach**

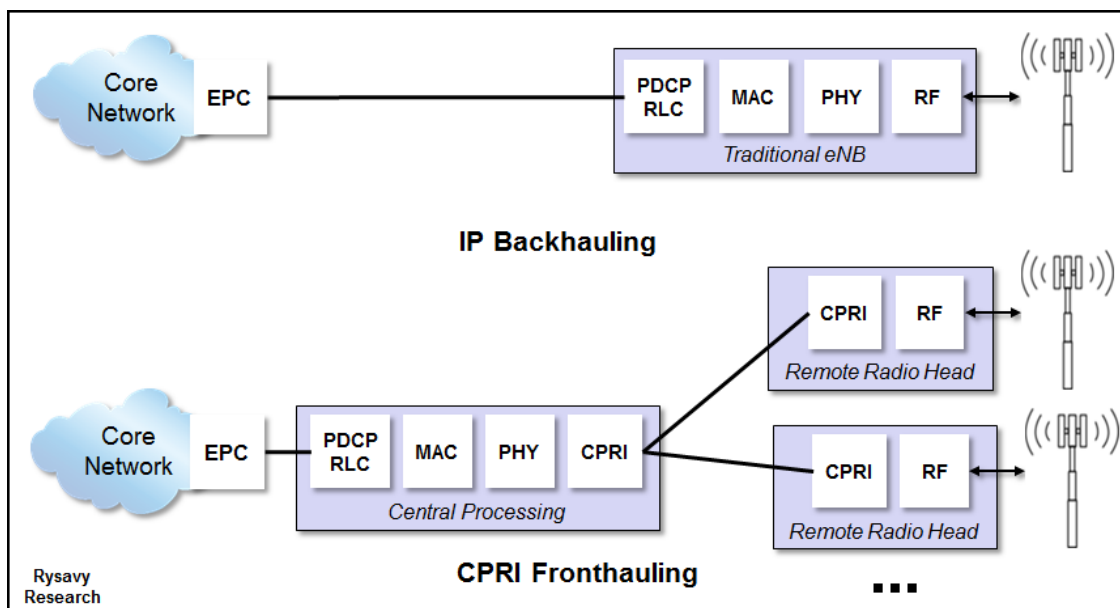

The next evolutionary step after centralizing baseband processing is to virtualize the processing by implementing the functions in software on commodity computing platforms, thus abstracting the functions from any specific hardware implementation.

C-RANs can vary by the extent of coverage, ranging from being highly localized and operating across a small number of sites to metropolitan-wide solutions. Other variables include existing deployments versus greenfield situations, new LTE and 5G technologies versus integrating legacy 2G and 3G technologies, and integrating Wi-Fi. Greater scope increases complexity but yields benefits including better load-balancing and greater flexibility in spectrum refarming.

<sup>156</sup> Dudu Bercovich, Ran Avital, “Holistic HetNet Hauling (3H),” Ceragon, February 2013. Available at [http://www.ceragon.com/images/Reasource\\_Center/White\\_Papers/Ceragon\\_Holistic\\_Hetnet\\_Hauling\\_White\\_Paper.pdf](http://www.ceragon.com/images/Reasource_Center/White_Papers/Ceragon_Holistic_Hetnet_Hauling_White_Paper.pdf).



Another design choice, as detailed in Table 31, is whether to centralize Layer 1 and Layer 2 functions (an RF-PHY split), or whether to keep Layer 1 at the base stations and centralize only Layer 2 (a PHY-MAC split).

**Table 31: Partially Centralized Versus Fully Centralized C-RAN**

	Fully Centralized	Partially Centralized
Transport Requirements	Multi-Gbps, usually using fiber	20 to 50 times less
Applications	Supports eICIC and CoMP	Supports centralized scheduling
Complexity	High	Lower
Benefit	Capacity gain	Lower capacity gain

Next Generation Mobile Networks studied the pros and cons of different fronthauling interfaces and published the results in March 2015.<sup>157</sup>

One application of C-RAN, proposed by NTT DOCOMO for 5G, uses C-RAN to coordinate small cells and macro cells, with the macro cell managing the control plane, and small cells operating in different bands than the macro, but being aggregated with the macro bands for higher capacity.<sup>158</sup>

Longer-term, perhaps in the 5G context, virtualized C-RANs may take away the very concept of cells. With methods such as beamforming and device-to-device communication, coverage may extend dynamically from a multitude of sources based on instantaneous load notifications and the radio resources available at different nodes.

In the past, RAN and core networks have been distinct entities, but over the next decade, the two may merge with more centralized, virtualized, and cloud-driven approaches.

Another form of virtualization is software-defined networking (SDN), an emerging trend in both wired and wireless networks. For cellular, SDN promises to reduce OPEX costs, simplify the introduction of new services, and improve scalability; all major infrastructure vendors are involved. The Open Networking Foundation explains that an SDN decouples the control and data planes, centralizing network state and intelligence, while abstracting the underlying network infrastructure from applications.<sup>159</sup> Virtualization of network

---

<sup>157</sup> Next Generation Mobile Networks, *Further Study on Critical C-RAN Technologies, Version 1.0*, March 2015. See sections 2.2 and 2.3. Available at [https://www.ngmn.org/uploads/media/NGMN\\_RANEV\\_D2\\_Further\\_Study\\_on\\_Critical\\_C-RAN\\_Technologies\\_v1.0.pdf](https://www.ngmn.org/uploads/media/NGMN_RANEV_D2_Further_Study_on_Critical_C-RAN_Technologies_v1.0.pdf).

<sup>158</sup> Presented at the Wireless Technology Association workshop, "Can Mobile Broadband Realize Its Full Potential? The Technology and Policy Paths to Massive Capacity Enhancement," Washington D.C., October 29, 2014.

<sup>159</sup> Open Networking Foundation, "Software-Defined Networking: The New Norm for Networks," <http://www.opennetworking.org/sdn-resources/sdn-library/whitepapers>, accessed June 20, 2014.

functions will be a complex, multiyear undertaking and will occur in stages, as shown in Figure 88.

**Figure 88: Software-Defined Networking and Cloud Architectures<sup>160</sup>**

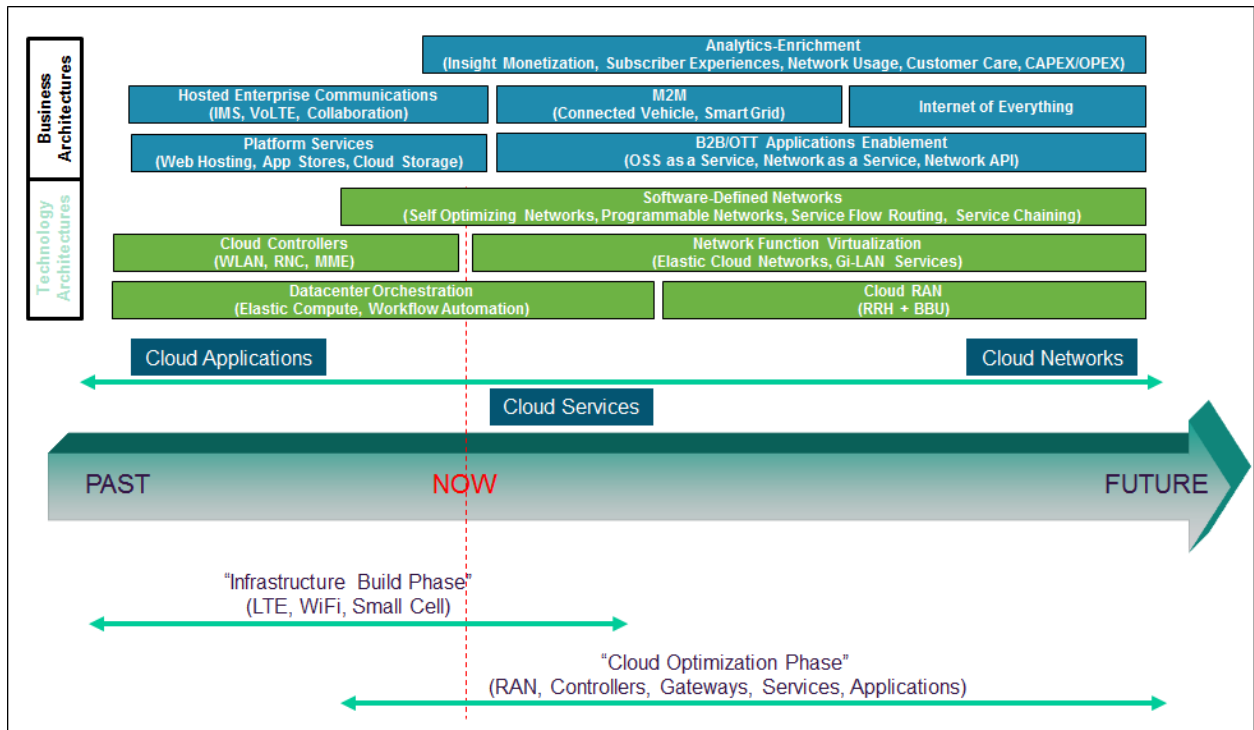

## Broadcast/Multicast Services

An important capability for 3G and evolved 3G systems is broadcasting and multicasting, wherein multiple users receive the same information using the same radio resource. This creates a more efficient approach to deliver video when multiple users desire the same content simultaneously. In a broadcast, every subscriber unit in a service area receives the information, whereas in a multicast, only users with subscriptions receive the information. Service areas for both broadcast and multicast can span either the entire network or a specific geographical area. Potential applications include sporting events, select news, venue-specific (shopping mall, museum) information, and even delivery of software upgrades. Giving users the ability to store and replay select content could further expand the scope of applications.

3GPP defined highly efficient broadcast/multicast capabilities for UMTS in Release 6 with MBMS. Release 7 defined optimizations through a feature called multicast/broadcast, single-frequency network operation that involves simultaneous transmission of the exact waveform across multiple cells. This enables the receiver to constructively superpose multiple MBMS Single Frequency Network (SFN), or MBSFN, cell transmissions. The result is highly efficient, WCDMA-based broadcast transmission technology that matches the benefits of OFDMA-based broadcast approaches.

<sup>160</sup> 4G Americas member contribution.

LTE also has a broadcast/multicast capability called Evolved MBMS (eMBMS). OFDM is particularly well-suited for efficient broadcasting, as shown in Figure 89, because the mobile system can combine the signal from multiple base stations, also an MBSFN approach, and because of the narrowband nature of OFDM. Normally, these signals would interfere with one another. The single frequency network is a cluster of cells that transmit the same content synchronously with a common carrier frequency.

**Figure 89: OFDM Enables Efficient Broadcasting**

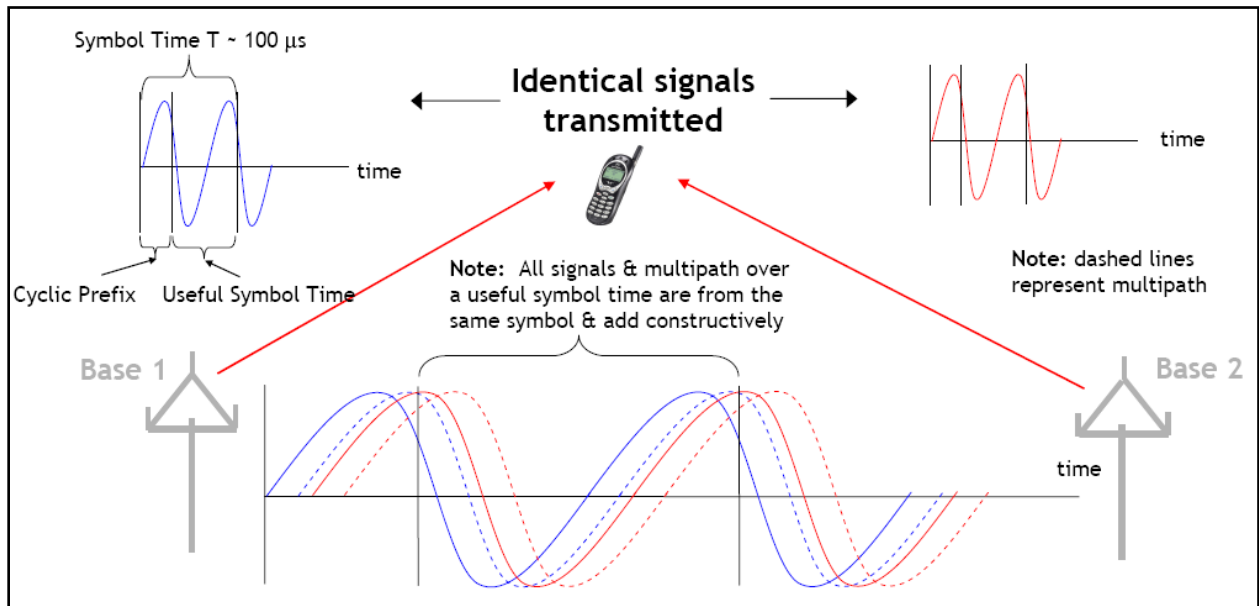

Despite various broadcast technologies being available, market adoption to date has been relatively slow. Internet trends have favored unicast approaches, with users viewing videos of their selection on demand, but there is increasing interest in using eMBMS with LTE to alleviate capacity demands.

## **Backhaul**

Connecting sites to core networks remains a challenge, whether for small cells or macro cells, especially as networks need to deliver higher bandwidth. Fiber is the gold standard, but it is not available everywhere and can be expensive, so operators use a combination of wired and wireless links. Table 32 and Table 33 summarize the methods and capabilities of the various available approaches.

**Table 32: Wired Backhaul Methods and Capabilities<sup>161</sup>**

Technology	Distance	Throughput Speed
Direct Fiber	80 km	Hundreds of Mbps to Gbps
Bonded VDSL2	To 5,000 feet	75 Mbps down, 12 Mbps up
FTTX	Most urban areas	Up to 2.5 Gbps down, 1.5 Gbps up
DOCSIS	Most urban areas	Up to 285 Mbps down, 105 Mbps up

**Table 33: Wireless Backhaul Methods and Capabilities<sup>162</sup>**

Technology	Distance	Line of Sight	Throughput Speed
Millimeter Wave (60 GHz)	1 km	Yes	1 Gbps
Millimeter Wave (70-80 GHz)	3 km (with speed tradeoff)	Yes	10 Gbps
Microwave (6-60 GHz)	Varies by frequency: 2-4 km typical at 30-42 GHz	Yes	1 Gbps+
Licensed sub 6 GHz	1.5 to 10 km	No	170 Mbps (20 MHz TDD), 400 Mbps+ with new technology
Unlicensed sub-6 GHz	Up to 250 meters	No	450 Mbps (IEEE 802.11n 3X3 MIMO)
TV White Space (802.11af-based)	1 to 5 km max throughput, 10 km+ possible	Depends on deployment model	80 Mbps in 6 MHz TDD with 4X4 MIMO
Satellite	Available everywhere	Yes	Up to 50 Mbps downlink, 15 Mbps uplink

<sup>161</sup> Small Cell Forum, "Backhaul Technologies for Small Cells," February 2013.

<sup>162</sup> Small Cell Forum, "Backhaul Technologies for Small Cells," February 2013.

## **UMTS TDD**

Most WCDMA and HSDPA deployments are based on FDD, which uses different radio bands for transmit and receive. In the alternate TDD approach, transmit and receive functions alternate in time on the same radio channel. 3GPP specifications include a TDD version of UMTS, called UMTS TDD.

TDD does not provide any inherent advantage for voice functions, which need balanced links—namely, the same amount of capacity in both the uplink and the downlink. Many data applications, however, are asymmetric, often with the downlink consuming more bandwidth than the uplink. A TDD radio interface can dynamically adjust the downlink-to-uplink ratio accordingly, hence balancing both forward-link and reverse-link capacity. Note that for UMTS FDD, the higher spectral efficiency achievable in the downlink versus the uplink addresses the asymmetrical nature of average data traffic.

The UMTS TDD specification also includes the capability to use joint detection in receiver-signal processing, which offers improved performance.

One consideration, however, relates to available spectrum. Various countries around the world including those in Europe, Asia, and the Pacific region have licensed spectrum available specifically for TDD systems. TDD is also a good choice for any spectrum that does not provide a duplex gap between forward and reverse links.

In the United States, there is limited spectrum specifically allocated for TDD systems, the major band being BRS at 2.5 GHz used by Clearwire for WiMAX and now LTE TDD.<sup>163</sup> UMTS TDD is not a good choice in FDD bands; it would not be able to operate effectively in both bands, thereby making the overall system efficiency relatively poor.

As discussed in more detail in the “WiMAX” section, TDD systems require network synchronization and careful coordination between operators or guardbands, which may be problematic in certain bands.

There has not been widespread deployment of UMTS TDD. Future TDD deployments of 3GPP technologies are likely to be based on LTE.

## **TD-SCDMA**

Time Division Synchronous Code Division Multiple Access (TD-SCDMA) is one of the official 3G wireless technologies being developed, mostly for deployment in China. Specified through 3GPP as a variant of the UMTS TDD System and operating with a 1.28 megachips per second (Mcps) chip rate versus 3.84 Mcps for UMTS TDD, the primary attribute of TD-SCDMA is that it supports very high subscriber densities, making it a possible alternative for wireless local loops. TD-SCDMA uses the same core network as UMTS, and it is possible for the same core network to support both UMTS and TD-SCDMA radio-access networks.

TD-SCDMA technology is not as mature as UMTS and CDMA2000, with 2008 being the first year of limited deployments in China in time for the Olympic Games. Although there are no planned deployments in any country other than China, TD-SCDMA could

---

<sup>163</sup> The 1910-1920 MHz band targeted unlicensed TDD systems but has never been used.

theoretically be deployed anywhere unpaired spectrum is available—such as the bands licensed for UMTS TDD—assuming appropriate resolution of regulatory issues.

## EDGE/EGPRS

Today, most GSM networks support EDGE, an enhancement to GPRS, which is the original packet data service for GSM networks.<sup>164</sup> GPRS provides a packet-based IP connectivity solution supporting a wide range of enterprise and consumer applications. GSM networks with EDGE operate as wireless extensions to the Internet and give users Internet access, as well as access to their organizations from anywhere. Peak EDGE user-achievable<sup>165</sup> throughput rates are up to 200 Kbps. Figure 90 depicts the system architecture.

**Figure 90: GSM/GPRS/EDGE Architecture**

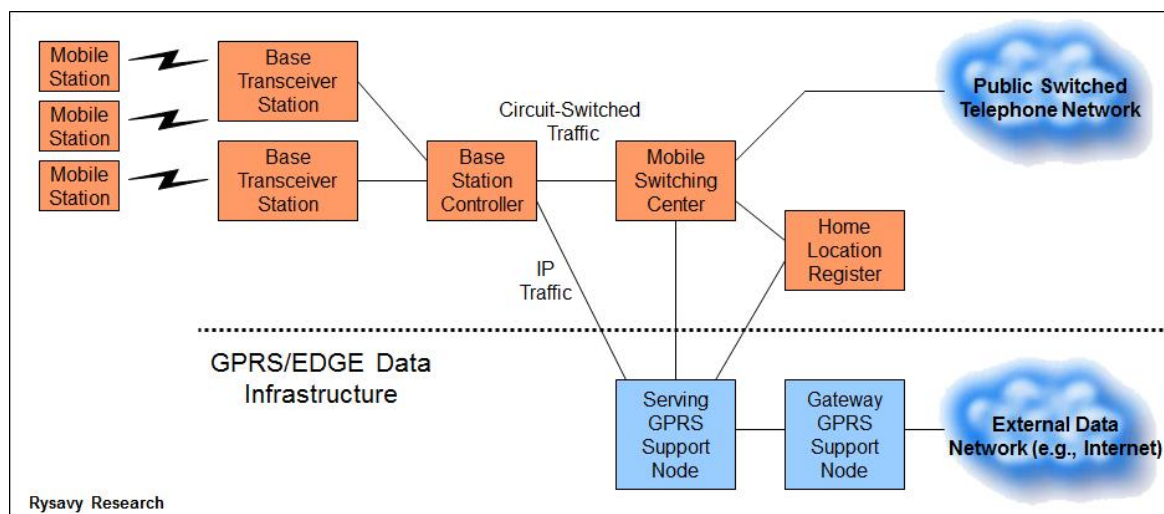

EDGE is essentially the addition of a packet-data infrastructure to GSM. In fact, this same data architecture is preserved in UMTS and HSPA networks, and the data architecture is technically referred to as GPRS for the core-data function in all of these networks. The term GPRS may also be used to refer to the initial radio interface, now supplanted by EDGE. Functions of the data elements are as follows:

1. The base station controller directs/receives packet data to/from the Serving GPRS Support Node (SGSN), an element that authenticates and tracks the location of mobile stations.
2. The SGSN performs the types of functions for data that the Mobile Switching Center (MSC) performs for voice. Each serving area has one SGSN, and it is often collocated with the MSC.

<sup>164</sup> GSM technology also provides circuit-switched data services, which are not described in this paper since they are seldom used.

<sup>165</sup> "Peak user-achievable" means users, under favorable conditions of network loading and signal propagation, can achieve this rate as measured by applications such as file transfer. Average rates depend on many factors and will be lower than these rates.

- The SGSN forwards/receives user data to/from the Gateway GPRS Support Node (GGSN), which can be viewed as a mobile IP router to external IP networks. Typically, there is one GGSN per external network (for example, the Internet). The GGSN also manages IP addresses, dynamically assigning them to mobile stations for their data sessions.

Another important element is the Home Location Register (HLR), which stores users' account information for both voice and data services. Of significance is that this same data architecture supports data services in GSM and in UMTS-HSPA networks, thereby simplifying operator network upgrades.

In the radio link, GSM uses radio channels of 200 kilohertz (kHz) width, divided in time into eight timeslots comprising 577 microseconds ( $\mu\text{s}$ ) that repeat every 4.6 msec, as shown in Figure 91. The network can have multiple radio channels (referred to as transceivers) operating in each cell sector. The network assigns different functions to each timeslot such as the Broadcast Control Channel (BCCH), circuit-switched functions like voice calls or data calls, the optional Packet Broadcast Control Channel (PBCCH), and packet data channels. The network can dynamically adjust capacity between voice and data functions, and it can also reserve minimum resources for each service. This scheduling approach enables more data traffic when voice traffic is low or, likewise, more voice traffic when data traffic is low, thereby maximizing overall use of the network. For example, the PBCCH, which expands the capabilities of the normal BCCH, may be set up on an additional timeslot of a Time Division Multiple Access (TDMA) frame when justified by the volume of data traffic.

**Figure 91: Example of GSM/EDGE Timeslot Structure<sup>166</sup>**

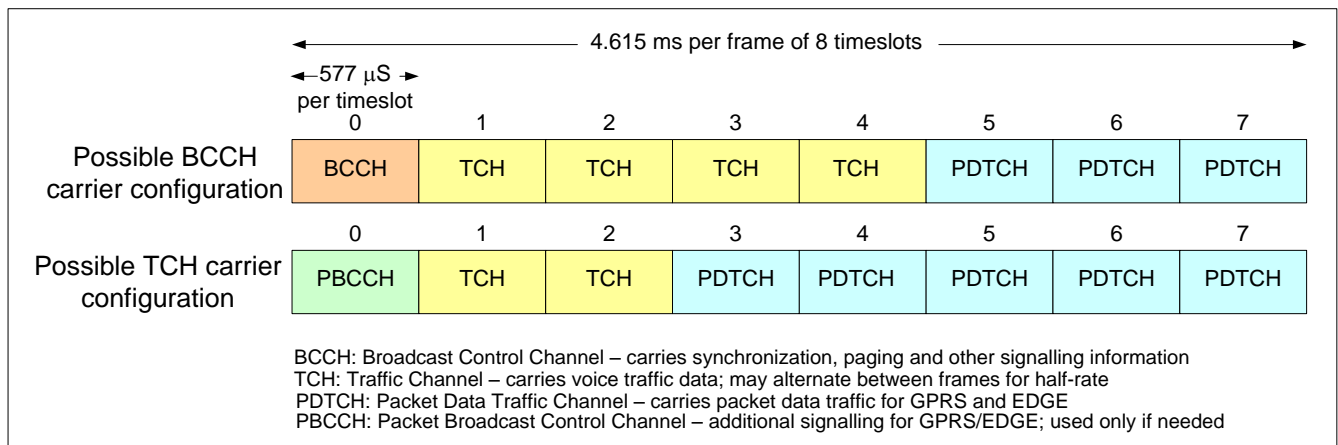

EDGE offers close coupling between voice and data services. In most networks, while in a data session, users can accept an incoming voice call, which suspends the data session, and then resume their data session automatically when the voice session ends. Users can also receive SMS messages and data notifications<sup>167</sup> while on a voice call, as described below.

<sup>166</sup> 4G Americas member company contribution.

<sup>167</sup> Example: WAP notification message delivered via SMS.

With respect to data performance, each data timeslot can deliver peak user-achievable data rates of up to about 40 Kbps. The network can aggregate up to five timeslots on the downlink and up to four timeslots on the uplink with current devices.

If multiple data users are active in a sector, they share the available data channels. As demand for data services increases, however, an operator can accommodate customers by assigning an increasing number of channels for data service that is limited only by that operator's total available spectrum and radio planning.

EDGE is an official 3G cellular technology that can be deployed within an operator's existing 850, 900, 1800, and 1900 MHz spectrum bands. EDGE capability is now largely standard in new GSM deployments. A GPRS network using the EDGE radio interface is technically called an Enhanced GPRS (EGPRS) network, and a GSM network with EDGE capability is referred to as GSM Edge Radio Access Network (GERAN). EDGE has been an inherent part of GSM specifications since Release 99. It is fully backward-compatible with older GSM networks, meaning that GPRS devices work on EDGE networks and that GPRS and EDGE terminals can operate simultaneously on the same traffic channels.

Dual Transfer Mode (DTM) devices can simultaneously communicate voice and data. DTM is a 3GPP-specified technology that enables new applications like video sharing while providing a consistent service experience (service continuity) with UMTS. Typically, a DTM end-to-end solution requires only a software upgrade to the GSM/EDGE radio network. There are a number of networks and devices supporting DTM.

A feature in Release 9 that applies to EDGE is the Enhanced Flexible Timeslot Assignment (EFTA), which allows for more efficient adaptation to varying uplink versus downlink transmission needs. The network allocates uplink and downlink timeslots that overlap in time, and the mobile station may either use the corresponding uplink timeslots for transmission or receive on the overlapping downlink time slot, if it has nothing to transmit. In addition, alternative EFTA multi-slot classes enable the support of as many as eight timeslots per downlink carrier (instead of five or six timeslots with multi-slot classes 30 to 45).

## ***TV White Spaces***

The FCC in the United States has ruled that unlicensed devices that have mechanisms to eliminate interference with TV broadcast channels may use TV channels that are not in use.<sup>168</sup> The rules provide for fixed devices and personal/portable devices. The FCC has suggested two usage types: broadband services to homes and businesses at a higher power level to fixed devices over larger geographical areas, and wireless portable devices at a low-power level in indoor environments.

The incentive auctions at 600 MHz will allocate new white-space frequencies, but the repacking process may also affect currently available frequencies.

To prevent interference with TV transmissions, both device types must employ geo-location capability with 50-meter accuracy (although fixed devices can store their position during installation) and possess the ability to access a database that lists permitted channels for a specific location. In addition, all devices must be able to sense the

---

<sup>168</sup> FCC, "Unlicensed Operation in the TV Broadcast Bands, Second Report and Order," FCC-08-260, November 2008. Available at [https://apps.fcc.gov/edocs\\_public/attachmatch/FCC-08-260A1.pdf](https://apps.fcc.gov/edocs_public/attachmatch/FCC-08-260A1.pdf).



spectrum to detect both TV broadcasting and wireless microphone signals. The rules include transmit power and emission limits.

These frequency-sensing and channel-change requirements are not supported by today's 3GPP, 3GPP2, and WiMAX technologies. The IEEE, however, has developed a standard, IEEE 802.22, based on IEEE 802.16 concepts, that complies with the FCC requirements. IEEE 802.22 is aimed at fixed or nomadic services, such as DSL replacement. IEEE 802.11af, an adaptation of IEEE 802.11 Wi-Fi, is another standard being developed for white-space spectrum. Some in the industry refer to white-space technology as "Super Wi-Fi," which misrepresents the technology because no existing Wi-Fi device can use white spaces.<sup>169</sup>

The industry is in the very early stages of determining the viability of using white-space spectrum.

In April 2012, the FCC issued a memorandum opinion and order that modified white-space rules, including increasing height above average terrain for fixed devices and the maximum permissible power spectral density for each type of device.<sup>170</sup>

Given the industry's move towards small-cell architectures that maximize data capacity, white-space networks, with their large coverage areas, are moving in the opposite direction. As such, they do not exploit spectrum efficiently. They are potentially well suited, however, for backhaul technology for Wi-Fi or cellular in developing countries.

---

<sup>169</sup> Rysavy Research, "White spaces networks are not "super" nor even Wi-Fi," *Gigaom*, Mar 2013. Available at <http://gigaom.com/2013/03/17/white-spaces-networks-are-not-super-nor-even-wi-fi/>.

<sup>170</sup> FCC, "Unlicensed Operation in the TV Broadcast Bands, Third Memorandum Opinion and Order," FCC 12-36, April 2012. Available at [http://hraunfoss.fcc.gov/edocs\\_public/attachmatch/FCC-12-36A1.pdf](http://hraunfoss.fcc.gov/edocs_public/attachmatch/FCC-12-36A1.pdf).

# Abbreviations and Acronyms

The following abbreviations are used in this paper. Abbreviations are defined on first use.

1G – First Generation

1xEV-DO – One Carrier Evolution, Data Optimized

1xEV-DV – One Carrier Evolution, Data Voice

1XRTT – One Carrier Radio Transmission Technology

2G – Second Generation

3G – Third Generation (meeting requirements set forth by the ITU-IMT project)

3GPP – Third Generation Partnership Project

3GPP2 – Third Generation Partnership Project 2

4G – Fourth Generation (meeting requirements set forth by the ITU IMT-Advanced project)

8-PSK – Octagonal Phase Shift Keying

AAS – Adaptive Antenna Systems

ABR – Allocation Retention Priority

AGW – Access Gateway

AMR – Adaptive Multi Rate

AMR-WB – Adaptive Multi-Rate Wideband

ANDSF – Access Network Discovery and Selection Function.

ANSI – American National Standards Institute

APCO – Association of Public Safety Officials

API – Application Programming Interface

APN – Access Point Name

ARP – Allocation Retention Priority

ARPU – Average Revenue per User

ARQ – Automatic Repeat Request

ATM – Asynchronous Transfer Mode

AWGN – Additive White Gaussian Noise Channel

AWS – Advanced Wireless Services

BCCH – Broadcast Control Channel

bps – bits per second

BRS – Broadband Radio Service

BSC – Base Station Controller

BTS – Base Transceiver Station

C/I – Carrier to Intermodulation Ratio

CAPEX- Capital Expenditure

CBF – Coordinated Beam Forming

CBS – Coordinated Beam Switching

CSS3 – Cascading Style Sheets 3 (CSS3)

CDD – Cyclic Delay Diversity  
CDF – Cumulative Distribution Function  
CDMA – Code Division Multiple Access  
CL – Closed Loop  
CL-SM – Closed Loop Spatial Multiplexing  
CMAS – Commercial Mobile Alert System  
CMOS – Complementary Metal Oxide Semiconductor  
CoMP – Coordinated Multi Point  
CP – Cyclic Prefix  
CPC – Continuous Packet Connectivity  
CPRI – Common Public Radio Interface  
CQI – Channel Quality Indicators  
C-RAN – Cloud Radio Access Network  
CRM – Customer Relationship Management  
CRS – Cell-specific Reference Signal  
CS – Convergence Sublayer  
CSFB – Circuit-Switched Fallback  
CTIA – Cellular Telephone Industries Association  
DAS – Distributed Antenna System  
DAS – Downlink EGPRS2-A Level Scheme  
dB – Decibel  
DBS – Downlink EGPRS2-B Level Scheme  
DC-HSPA – Dual Carrier HSPA  
DFT – Discrete Fourier Transform  
DL – Downlink  
DPCCH – Dedicated Physical Control Channel  
DPS – Dynamic Point Selection  
DSL – Digital Subscriber Line  
DSMIPv6 – Dual Stack Mobile IPv6  
DTM – Dual Transfer Mode  
DRX – Discontinuous Reception  
D-TxAA – Double Transmit Adaptive Array  
DVB-H – Digital Video Broadcasting Handheld  
E-DCH – Enhanced Dedicated Channel  
EBCMCS – Enhanced Broadcast Multicast Services  
EDGE – Enhanced Data Rates for GSM Evolution  
EFTA – Enhanced Flexible Timeslot Assignment  
EGPRS – Enhanced General Packet Radio Service  
eICIC – Enhanced Inter-Cell Interference Coordination

eMBMS – Evolved Multimedia Broadcast Multicast Services  
eNodeB – Evolved Node B  
EAP – Extensible Authentication Protocol  
EPC – Evolved Packet Core  
EPDCCH – Enhanced Physical Downlink Control Channel  
ePDG – Enhanced Packet Data Gateway  
EPS – Evolved Packet System  
ERP – Enterprise Resource Planning  
eSAMOG – Enhanced S2a-based Mobility over GTP  
eSRVCC – Enhanced Single-Radio Voice Call Continuity  
ETRI – Electronic and Telecommunications Research Institute  
ETSI – European Telecommunications Standards Institute  
E-UTRAN – Enhanced UMTS Terrestrial Radio Access Network  
EVS – Enhanced Voice Services (codec)  
FE-FACH – Further Enhanced Forward Access Channel  
EV-DO – Evolution, Data Optimized  
EV-DV – Evolution, Data Voice  
EVRG – Enhanced Variable Rate Codec  
FCC – Federal Communications Commission  
FDD – Frequency Division Duplex  
feICIC – Further enhanced ICIC  
FirstNet -- First Responder Network Authority  
Flash OFDM – Fast Low-Latency Access with Seamless Handoff OFDM  
FLO – Forward Link Only  
FMC – Fixed Mobile Convergence  
FP7 – Seventh Framework Programme  
FTP – File Transfer Protocol  
GAA – General Authorized Access  
GAN – Generic Access Network  
GB – Gigabyte  
Gbps – Gigabits Per Second  
GBR – Guaranteed Bit Rate  
GByte – Gigabyte  
GCS – Group Communication Service  
GERAN – GSM EDGE Radio Access Network  
GFDM – Generalized Frequency-Division Multiplexing  
GGSN – Gateway GPRS Support Node  
GHz – Gigahertz  
GMSK – Gaussian Minimum Shift Keying

GPRS – General Packet Radio Service  
G-Rake – Generalized Rake Receiver  
GSM – Global System for Mobile Communications  
GSMA – GSM Association  
HARQ – Hybrid Automatic Repeat Request  
HD – High Definition  
HetNet – heterogeneous network  
HLR – Home Location Register  
Hr – Hour  
HSDPA – High Speed Downlink Packet Access  
HS-FACH – High Speed Forward Access Channel  
HS-PDSCH - High Speed Physical Downlink Shared Channels  
HS-RACH – High Speed Reverse Access Channel  
HSPA – High Speed Packet Access (HSDPA with HSUPA)  
HSPA+ – HSPA Evolution  
HSS – Home Subscriber Server  
HSUPA – High Speed Uplink Packet Access  
Hz – Hertz  
ICIC – Inter-Cell Interference Coordination  
ICN – Information-Centric Networking  
ICS – IMS Centralized Services  
ICT – Information and Communication Technologies  
IEEE – Institute of Electrical and Electronic Engineers  
IETF – Internet Engineering Taskforce  
IFFT – Inverse Fast Fourier Transform  
IFOM – IP Flow and Seamless Offload  
IM – Instant Messaging  
IMS – IP Multimedia Subsystem  
IMT – International Mobile Telecommunications  
IMT-Advanced - International Mobile Telecommunications-Advanced  
IRC – Interference Rejection Combining  
IoT – Internet of Things  
IPR - Intellectual Property Rights  
IP – Internet Protocol  
IPTV – Internet Protocol Television  
IR – Incremental Redundancy  
ISI – Intersymbol Interference  
ISP – Internet Service Provider  
ITU – International Telecommunication Union

JCP – Java Community Process  
JR – Joint Reception  
JT – Joint Transmission  
Kbps – Kilobits Per Second  
kHz – Kilohertz  
km – Kilometer  
LAA – License-Assisted Access  
LBT – Listen Before Talk  
LIPA – Local IP Access  
LMDS – Local Multipoint Distribution Service  
LTE – Long Term Evolution  
LTE-A – LTE-Advanced  
LTE-TDD – LTE Time Division Duplex  
LTE-U – LTE Unlicensed  
LSTI – LTE/SAE Trial Initiative  
LWA – LTE Wi-Fi Aggregation  
M2M – Machine-to-machine  
MAC – Medium Access Control  
MAPCON – Multi-Access PDN Connectivity  
MB – Megabyte  
MBMS – Multimedia Broadcast/Multicast Service  
Mbps – Megabits Per Second  
MBR – Maximum Bit Rate  
MBSFN – Multicast/broadcast, Single Frequency  
MCPA – Mobile Consumer Application Platform  
Mcps – Megachips Per Second  
MCPTT – Mission-Critical Push-to-Talk  
MCS – Modulation and Coding Scheme  
MCW – Multiple Codeword  
MDT – Minimization of Drive Tests  
MEAP – Mobile Enterprise Application Platforms  
MediaFLO – Media Forward Link Only  
METIS – Mobile and wireless communications Enablers for the Twenty-twenty Information Society  
MHz – Megahertz  
MID – Mobile Internet Devices  
MIMO – Multiple Input Multiple Output  
MMSE – Minimum Mean Square Error  
mITF – Japan Mobile IT Forum  
MMDS – Multichannel Multipoint Distribution Service

MME – Mobile Management Entity  
MOS – Mean Opinion Score  
MRxD – Mobile Receive Diversity  
ms – millisecond  
MS – Mobile Station  
MSA – Mobile Service Architecture  
MSC – Mobile Switching Center  
MTC – Machine Type Communications  
MTC-IWF – Machine-Type Communications Interworking Function (MTC-IWF)  
msec – millisecond  
MU-MIMO – Multi-User MIMO  
NENA – National Emergency Number Association  
NGMC – Next Generation Mobile Committee  
NGMN – Next Generation Mobile Networks Alliance  
NOMA – Non-Orthogonal Multiple Access  
NTIA – National Telecommunications and Information Administration  
OFDM – Orthogonal Frequency Division Multiplexing  
OFDMA – Orthogonal Frequency Division Multiple Access  
OL-SM – Open Loop Spatial Multiplexing  
OMA – Open Mobile Alliance  
ORI – Open Radio Equipment Interface  
PA – Priority Access  
PAL – Priority Access License  
PAR – Peak to Average Ratio  
PBCCH – Packet Broadcast Control Channel  
PCH – Paging Channel  
PCRF – Policy Control and Charging Rules Function  
PCS – Personal Communications Service  
PDN – Packet Data Network  
PGW – Packet Gateway  
PHY – Physical Layer  
PMI – Precoding Matrix Indication  
PMIPv6 – Proxy Mobile IPv6  
PoC – Push-to-talk over Cellular  
PSH – Packet Switched Handover  
PSK – Phase-Shift Keying  
QAM – Quadrature Amplitude Modulation  
QCI – Quality of Service Class Identifier  
QLIC – Quasi-Linear Interference Cancellation

QoS – Quality of Service  
QPSK – Quadrature Phase Shift Keying  
RAB – Radio Access Bearer  
RAN – Radio Access Network  
RCS – Rich Communications Suite  
REST – Representational State Transfer  
RF – Radio Frequency  
RNC – Radio Network Controller  
ROHC – Robust Header Compression  
RRC – Radio Resource Control  
RRH – Remote Radio Head  
RRU – Remote Radio Unit  
RTP – Real Time Transport Protocol  
RTSP – Real Time Streaming Protocol  
SAE – System Architecture Evolution  
SaMOG – S2a-based Mobility over GTP  
SAS – Spectrum Access System  
SC-FDMA – Single Carrier Frequency Division Multiple Access  
SCMA – Sparse Coded Multiple Access  
SCRI – Signaling Connection Release Indication  
SCW – Single Codeword  
SDMA – Space Division Multiple Access  
SDN – Software Defined Networking  
SDP – Session Description Protocol  
sec – Second  
SFBA – Space Frequency Block Code  
SFN – Single Frequency Network  
SGSN – Serving GPRS Support Node  
SGW – Serving Gateway  
SIC – Successive Interference Cancellation  
SIM – Subscriber Identity Module  
SIMO – Single Input Multiple Output  
SINR – Signal to Interference Plus Noise Ratio  
SIP – Session Initiation Protocol  
SIPTO – Selected IP Traffic Offload  
SISO – Single Input Single Output  
SMS – Short Message Service  
SNR – Signal to Noise Ratio  
SON – Self-Organizing Network



SPS – Semi-Persistent Scheduling  
SRVCC – Single Radio Voice Call Continuity  
SU-MIMO – Single User MIMO  
SVDO – Simultaneous 1XRTT Voice and EVDO Data  
SVLTE – Simultaneous Voice and LTE  
TCH – Traffic Channel  
TCP/IP – Transmission Control Protocol/IP  
TD – Transmit Diversity  
TDD – Time Division Duplex  
TDMA – Time Division Multiple Access  
TD-SCDMA – Time Division Synchronous Code Division Multiple Access  
TD-CDMA – Time Division Code Division Multiple Access  
TETRA – Terrestrial Trunked Radio  
TIA/EIA – Telecommunications Industry Association/Electronics Industry Association  
TISPAN – Telecoms and Internet converged Services and Protocols for Advanced Networks  
TTI – Transmission Time Interval  
UAS – Uplink EGPRS2-A Level Scheme  
UBS – Uplink EGPRS2-B Level Scheme  
UE – User Equipment  
UFMC – Universal Filtered Multi-Carrier  
UICC – Universal Integrated Circuit Card  
UL – Uplink  
UMA – Unlicensed Mobile Access  
UMB – Ultra Mobile Broadband  
UMTS – Universal Mobile Telecommunications System  
URA-PCH – UTRAN Registration Area Paging Channel  
URI – Uniform Resource Identifier  
us – Microsecond  
USIM – UICC SIM  
UTRAN – UMTS Terrestrial Radio Access Network  
VAMOS – Voice Services over Adaptive Multi-User Channels on One Slot  
VDSL – Very-High-Bit-Rate DSL  
VEPC – Virtualized EPC  
ViLTE – Video Over LTE  
VoIP – Voice over Internet Protocol  
VoHSPA – Voice over HSPA  
VOLGA – Voice over LTE Generic Access  
VoLTE – Voice over LTE  
VPN – Virtual Private Network

WAP – Wireless Application Protocol  
WBA – Wireless Broadband Alliance  
WCDMA – Wideband Code Division Multiple Access  
WCS – Wireless Communication Service  
WebRTC – Web Real-Time Communication  
Wi-Fi – Wireless Fidelity  
WiMAX – Worldwide Interoperability for Microwave Access  
WLAN – Wireless Local Area Network  
WMAN – Wireless Metropolitan Area Network  
WMM – Wi-Fi Multimedia  
WRC – World Radiocommunication Conference

## **Additional Information**

4G Americas maintains complete and current lists of market information including HSPA, HSPA+ and LTE deployments worldwide, available for free download on its Web site: <http://www.4gamericas.org>.

If there are any questions regarding the download of this information, please call +1 425 372 8922 or e-mail Anna Altavas, Public Relations Coordinator at [info@4gamericas.org](mailto:info@4gamericas.org).

This white paper was written for 4G Americas by Rysavy Research (<http://www.rysavy.com>) and utilized a composite of statistical information from multiple resources.

**The contents of this paper reflect the independent research, analysis, and conclusions of Rysavy Research and may not necessarily represent the comprehensive opinions and individual viewpoints of each particular 4G Americas Board member company.**

**Rysavy Research provides this document and the information contained herein to you for informational purposes only. Rysavy Research provides this information solely on the basis that you will take responsibility for making your own assessments of the information.**

**Although Rysavy Research has exercised reasonable care in providing this information to you, Rysavy Research does not warrant that the information is error-free. Rysavy Research disclaims and in no event shall be liable for any losses or damages of any kind, whether direct, indirect, incidental, consequential, or punitive arising out of or in any way related to the use of the information.**

**Copyright © 2015 Rysavy Research, LLC. All rights reserved.**

<http://www.rysavy.com>